

MODEL : FD90

雙段 2-Stage

RATIO : 15, 20, 25, 30, 35, 40, 50, 70, 100

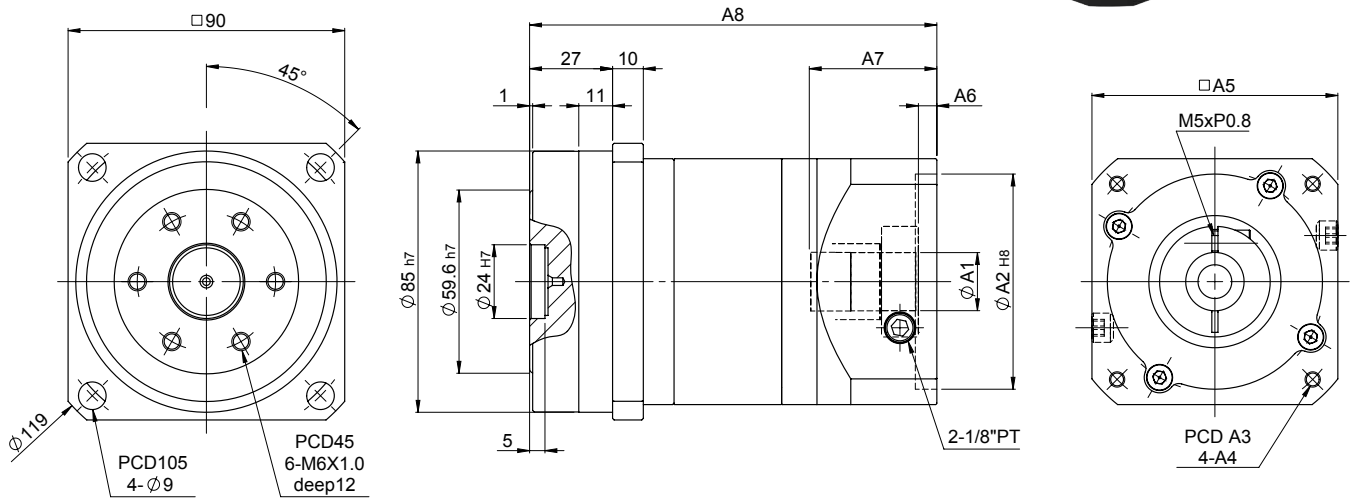
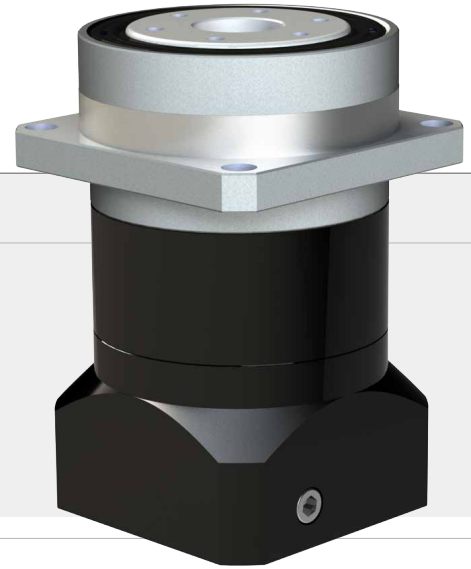

入力法蘭尺寸表 Dimension of Input Flange

unit: mm

No.	ØA1	ØA2	A3	A4	A5	A6	A7	A8
1	14 · 19	50	70	M5	80	5.5	33.5	124.5
2	14 · 19	70	90	M6	80	6	41.5	132.5

規格 Parameter	代號	單位 Unit	15	20	25	30	35	40	50	70	100
額定輸出扭矩 Rated Output Torque (Nominal output torque)	T_{2N}	Nm	112	110	108	112	105	110	108	105	100
轉動慣量 Mass Moments of Inertia		kg.cm ²	0.45	0.42	0.42	0.42	0.42	0.42	0.42	0.42	0.42
最大加速扭矩 Max. Acceleration Torque	T_{2B}	Nm	1.8 倍額定輸出扭矩 1.8 Times of Rated Output Torque								
最大輸出扭矩 Max. Output Torque	T_{2NOT}	Nm	3 倍額定輸出扭矩 3 Times of Rated Output Torque								
急停扭矩 Emergency Stop Torque											
額定輸入轉速 Rated Input Speed	n_{IN}	rpm	3,000								
最大輸入轉速 Max. Input Speed	n_{IB}	rpm	5,000								
扭轉剛性 Torsional Rigidity		Nm/arcmin	12								
容許徑向力 Max. Radial Force	F_{2rB}	N	1,400								
容許軸向力 Max. Axial Force	F_{2aB}	N	660								
使用壽命 Service Life	L_H	hr	S5 周期運轉 : >30,000 (S1 連續運轉 : >15,000 hrs) S5 Cycle Operation: >30,000 (S1 Continuous Operation: >15,000 hrs)								
效率 Efficiency	η	%	≥ 95%								
使用溫度 Operating Temperature		°C	- 25° C ~ + 90° C								
潤滑 Lubrication			全合成潤滑油脂 Synthetic Grease								
防護等級 Protection Class			IP 65								
安裝方向 Mounting Position			任意 Any								
噪音值 Noise Level		dB	≤ 62 dB								
重量 Weight ±2%		Kg	3.3								