

ST-RP series

RATIO : 10.15.20.25.30.40.50 (雙段 2-Stage)



搭配行星減速機 - 螺桿式

Fitted with Planetary Reducer - Ball Screw

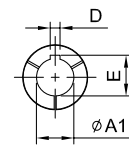
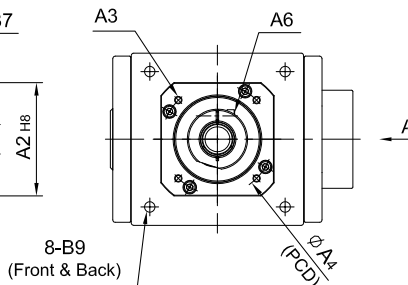
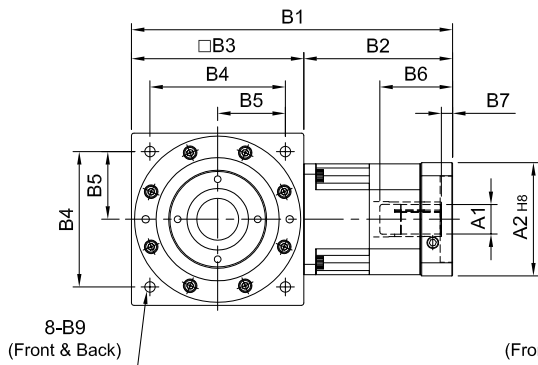
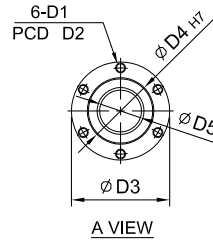
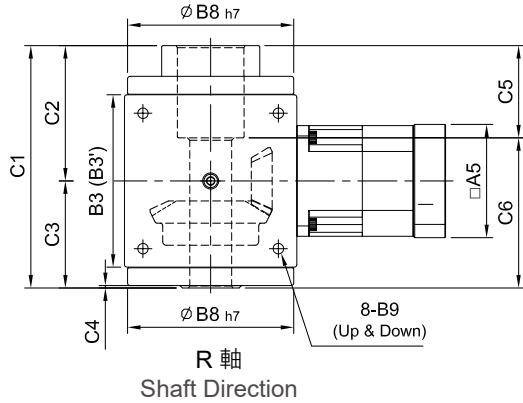

(210#~240#)

ØA1	D	E
Ø28	8	31.3
Ø32	10	35.3
Ø35	10	38.3
Ø38	10	41.3

unit: mm

Model Code	75	90	110	140	170	210	240		
A	A1	8 · 9 · 11	11 · 14 · 16 · 19	11 · 14 · 16 · 19	(14) · 16 · 19	16 · 19 · 22 · 24	22 · 24 · 28 · 32 · 35	28 · 32 · 35 · 38	35 · 38 · 42 · 48 · 55
	A2	30 · 40 · 50	50 · 60 · 70	50 · 60 · 70	50 · 70 · 80 · 95	70 · 80 · 95 · 110	95 · 110 · 130	110 · 130 · 180	114.3 · 180 · 230 · 250
	A3	M3 · M4 · M5	M4 · M5 · M6	M4 · M5 · M6	M5 · M6	M5 · M6 · M8	M6 · M8 · M10	M8 · M10 · M12	M10 · M12 · M16
	A4	46 · 60 · 63	70 · 75 · 90	70 · 75 · 90	70 · 90 · 100 · 115	90 · 100 · 115 · 145	115 · 145 · 165	145 · 165 · 200	200 · 215 · 265 · 300
	A5	46 · 55	64 · 70 · 80	64 · 70 · 80	80 · 92 · 110	92 · 110 · 130	122 · 130 · 150	146 · 150 · 190	182 · 200 · 250 · 265
	A6	M4 x P0.7	M5 x P0.8	M5 x P0.8	M5 x P0.8	M6 x P1.0	M8 x P1.25	M10 x P1.5	M10 x P1.5
B	B1	137	149 · 157	165 · 173	(191) · 203	260	313 · 334	399	479.5
	B2	62	74 · 82	75 · 83	(81) · 93	120	143 · 164	189	239.5
	B3(B3')	75(74)	75(74)	90	110	140	170(168)	210	240
	B4	60	60	72	88	110	134	170	195
	B5	30	30	36	44	55	67	85	95
	B6	26	33.5 · 41.5	33.5 · 41.5	(33.5) · 45.5	59	67 · 83	85	116.5
	B7	5	5	6	(6) · 10	9	10 · 11	10	13.5
	B8	73	73	88	106	135	164	205	228
B9	M6 x P1.0	M6 x P1.0	M6 x P1.0	M8 x P1.25	M10 x P1.5	M12 x P1.75	M16 x P2.0	M16 x P2.0	
C	C1	106	106	127	156	197	223	267	309
	C2	57	57	68	84	109	121	142	162.5
	C3	49	49	59	72	88	102	125	146.5
	C4	1.25	1.25	2	2	2	2.25	2.25	2.5
	C5	33	33	44	55	75	72	82	92
	C6	73	73	83	101	122	153	185	217
D	D1	M4 x P0.7	M4 x P0.7	M5 x P0.8	M5 x P0.8	M8 x P1.25	M10 x P1.5	M10 x P1.5	M12 x P1.75
	D2	36	36	40	45	70	77	84	97
	D3	41.7	41.7	46.7	57.7	79.7	89.7	99.7	117.7
	D4	26	26	30	36	54	58	64	75
	D5	15	15	18	22	34	38	42	54
Weight ±3% (kg)	3.6	3.6	4.8	8.5	14.2	24	52		