

# ST-DM series

RATIO : 1.2.3.4.5 (單段 1-Stage)



單入力軸心 - 雙邊免鍵軸套

Single Input Shaft - Double Clamping

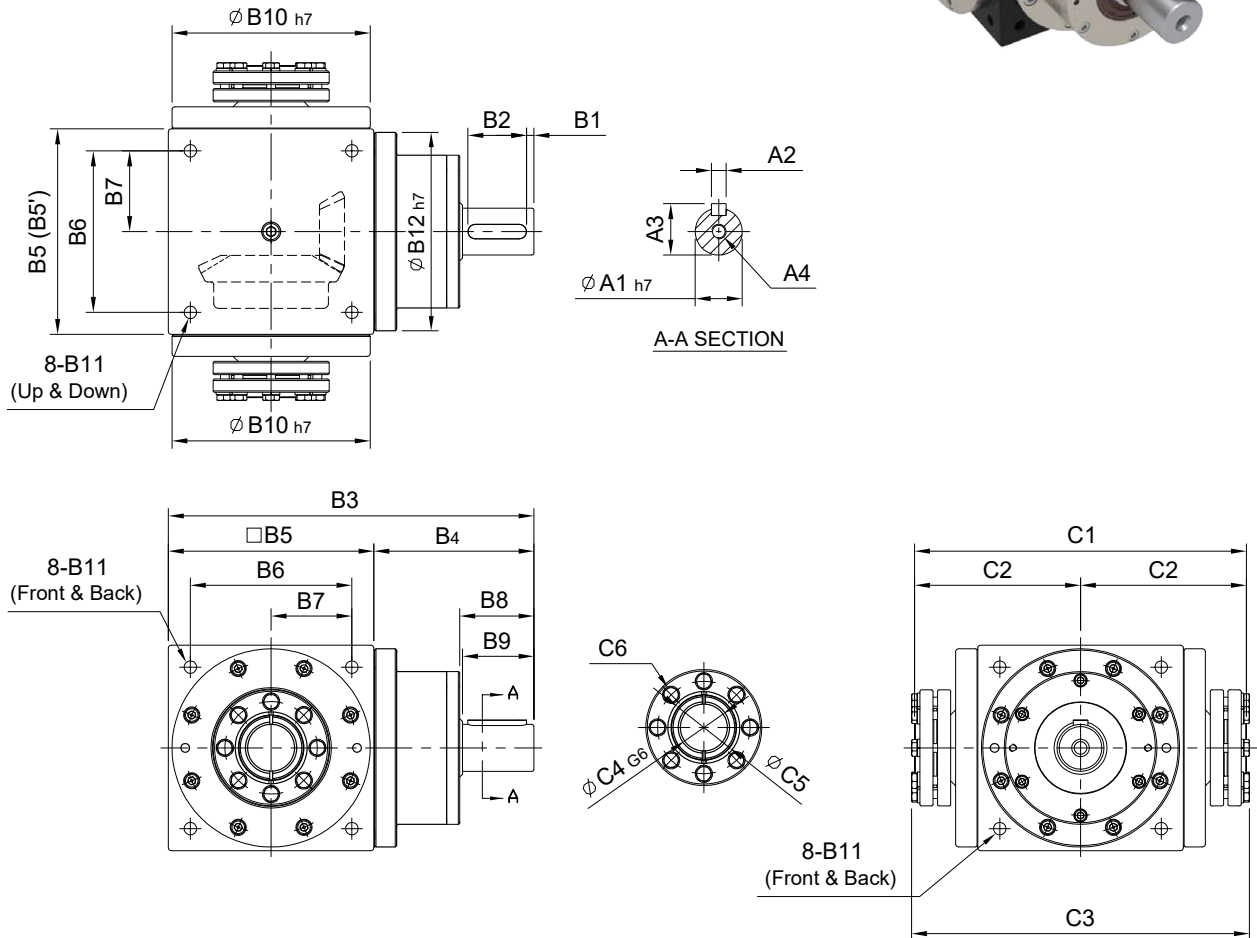

unit: mm

Model Code	65	65 (1:1)	75	90	110	140	170	210	240	280
	<b>A</b>									
A1	14		16	18	22	32	40	50	55	60
A2	5		5	6	6	10	12	14	16	18
A3	16		18	20.5	24.5	35	43	53.5	59	64
A4	M5 x P0.8		M5 x P0.8	M8 x P1.25	M8 x P1.25	M10 x P1.5	M12 x P1.75	M12 x P1.75	M16 x P2.0	M16 x P2.0
<b>B</b>										
B1	2.5		2.5	5	5	5	5	5	5	5
B2	15		25	25	30	40	50	65	70	90
B3	127.5		143	168.5	207	250	300	375	430	505
B4	62.5		68	78.5	97	110	130	165	190	225
B5(B5')	65		75(74)	90	110	140	170(168)	210	240	280
B6	52		60	72	88	110	134	170	190	220
B7	26		30	36	44	55	67	85	95	110
B8	22		32	38	43	53.5	64	77	82	105
B9	20		30	35	40	50	60	75	80	100
B10	62	64	73	88	106	135	164	205	228	275
B11	M5 x P0.8		M6 x P1.0	M6 x P1.0	M8 x P1.25	M10 x P1.5	M12 x P1.75	M16 x P2.0	M16 x P2.0	M16 x P2.0
B12	-		73	88	106	135	164	205	228	219
<b>C</b>										
C1	124	129	140	158	194	230	276	320	356	412
C2	62	64.5	70	79	97	115	138	160	178	206
C3	136	138	150	166	198	232	280	327	370	411.7
C4	14		14	18	22	32	40	50	55	60
C5	22		22	28	34	44	52	65	73	83
C6	6-M6		6-M6	6-M6	8-M6	8-M6	8-M8	8-M8	8-M8	8-M10
Weight $\pm 3\%$ (kg)	2.1		2.8	4.9	8.59	15.5	25	53	74.4	