

MODEL : JT90

RATIO : 2 (單段 1-Stage)

JT

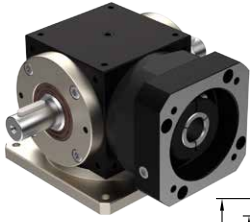

JT-FV

入力法蘭 - 雙出力軸心

Input Flange - Double Output Shaft

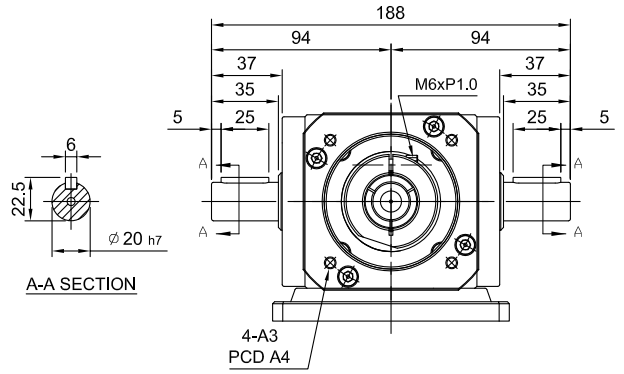
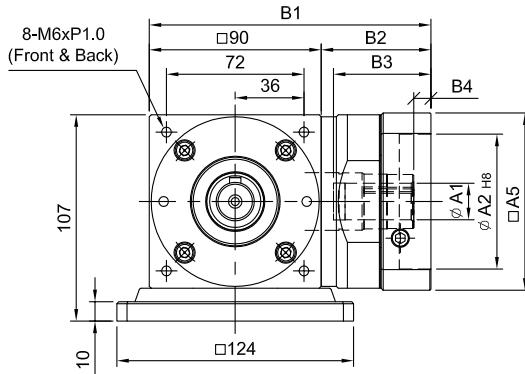
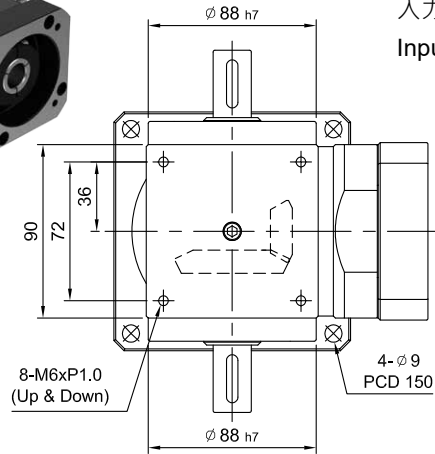

unit:mm

Model Code	90
A1	16 · 19 · 22 · 24
A2	70 · 80 · 95 · 110
A3	M5 · M6 · M8
A4	90 · 100 · 115 · 145
A5	92 · 110 · 130
B1	148 · 162
B2	58 · 72
B3	51 · 65.5
B4	9 · 23.5
Weight ±3% (kg)	5.4



JT-FP1

入力法蘭 - 滾珠螺桿式 - 1 出軸

Input Flange - Ball Screw - 1 Shaft

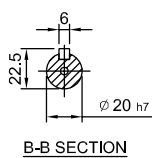
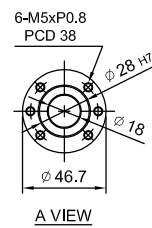
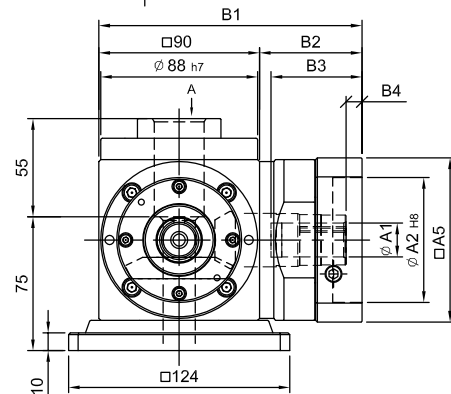
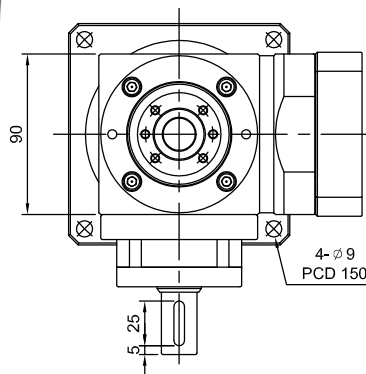

unit:mm

Model Code	90
A1	16 · 19 · 22 · 24
A2	70 · 80 · 95 · 110
A3	M5 · M6 · M8
A4	90 · 100 · 115 · 145
A5	92 · 110 · 130
B1	148 · 162
B2	58 · 72
B3	51 · 65.5
B4	9 · 23.5
Weight ±3% (kg)	7.1

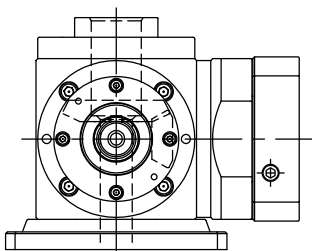

R 軸
Shaft Direction

