

SERVOBOX Planetary Reducers

MODEL : SE-A

三段 3-Stage

RATIO : 125, 150, 175, 200, 250, 300, 350,
400, 450, 500, 600, 700, 800, 900, 1000



(180A#~220A#)

φC3	D	E
φ28	8	31.3
φ32	10	35.3
φ35	10	38.3
φ38	10	41.3
φ42	12	45.3
φ48	14	51.8
φ55	16	59.3

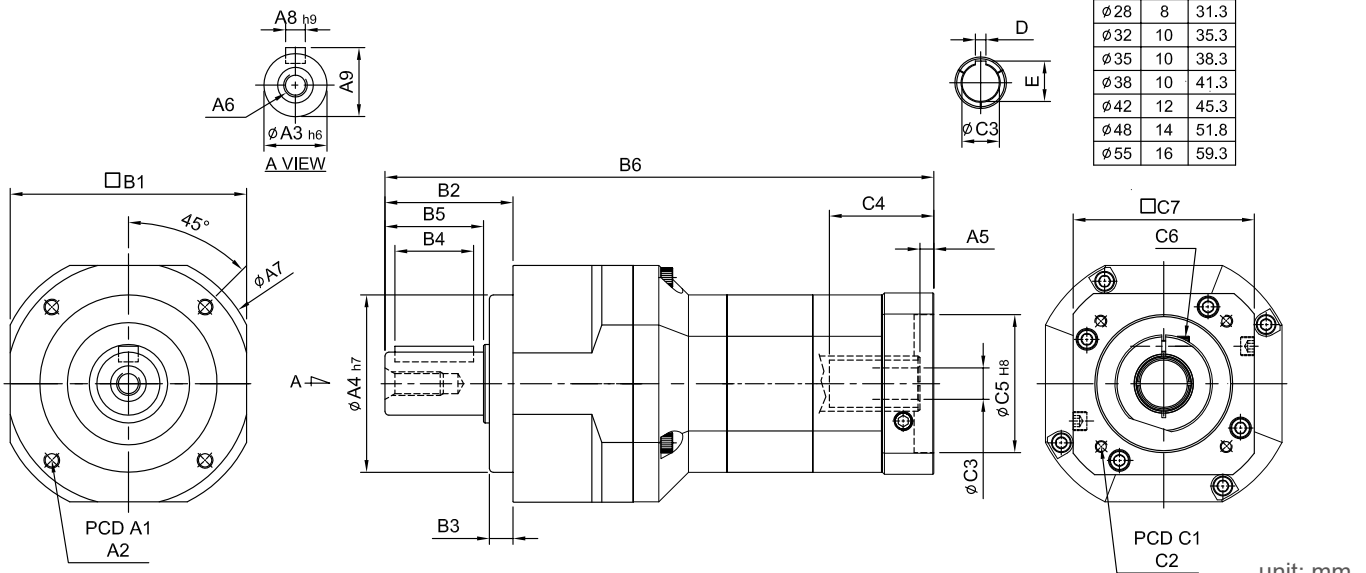

unit: mm

Model Code	62A	90A	120A	142A	180A	220A	
A	A1	62	82	110	140	218	
	A2	M5 x P0.8	M6 x P1.0	M8 x P1.25	M10 x P1.5	M12 x P1.75	M16 x P2.0
	A3	16	22	32	40	55	75
	A4	50	70	90	120	160	180
	A5	6.5	6	9 · 23.5	10 · 20	10	11.5 · 13.5
	A6	M5 x P0.8	M8 x P1.25	M10 x P1.5	M12 x P1.75	M14 x P2.0	M16 x P2.0
	A7	70	102	134	166	215	252
	A8	5	6	10	12	16	20
	A9	18	24.5	35	43	59	79.5
B	B1	62	90	120	142	180	220
	B2	36	46	65	92	106	139
	B3	7	8	12	15	20	30
	B4	20	30	40	65	70	90
	B5	28	36	50	74	82	104
	B6	165.5	204.5 · 212.5	284.5	354.5	425	527.5
C	C1	46 · 60 · 63	70 · 75 · 90	90 · 100 · 115 · 145	115 · 145 · 165	145 · 165 · 215	200 · 215 · 265
	C2	M3 · M4 · M5	M4 · M5 · M6	M5 · M6 · M8	M6 · M8 · M10	M8 · M10 · M12	M10 · M12
	C3	8 · 9 · 11	11 · 14 · 16 · 19	16 · 19 · 22 · 24	22 · 24 · 28 · 32	28 · 32 · 35 · 38	35 · 38 · 42 · 48 · 55
	C4	26 · 30.5	33.5 · 41.5	59 · 73.5	67 · 77	84.5	114.5 · 116.5
	C5	30 · 40 · 50	50 · 60 · 70	70 · 80 · 95 · 110	95 · 110 · 130	110 · 130 · 180	114.3 · 180 · 230
	C6	M4 x P0.7	M5 x P0.8	M6 x P1.0	M8 x P1.25	M10 x P1.5	M10 x P1.5
	C7	46 · 55	64 · 70 · 80	92 · 110 · 130	122 · 130 · 150	146 · 150 · 190	182 · 200 · 250

High Precision Planetary Reducer

規格 Parameter	代號	單位 Unit	速比 Ratio	62A	90A	120A	142A	180A	220A
額定輸出扭矩 Rated Output Torque (Nominal output torque)	T_{2N}	Nm	125	48	160	333	618	1,189	2,010
			150	59	165	335	625	1,206	2,030
			175	45	149	309	573	1,108	1,870
			200	51	146	300	555	1,069	1,804
			250	48	160	333	618	1,189	2,010
			300	45	151	311	583	1,118	1,911
			350	45	149	309	573	1,108	1,870
			400	43	143	298	553	1,070	1,824
			450	44	145	278	516	993	1,694
			500	48	160	333	618	1,189	2,010
			600	45	151	311	583	1,118	1,911
			700	45	149	309	573	1,108	1,870
800	43	143	298	553	1,070	1,824			
900	44	145	278	516	993	1,694			
1000	43	141	294	549	1,059	1,779			
最大加速扭矩 Max. Acceleration Torque	T_{2B}	Nm	125 ~ 1000	1.8 倍額定輸出力矩 1.8 Times of Rated Output Torque					
最大輸出扭矩 Max. Output Torque	T_{2NOT}	Nm	125 ~ 1000	3 倍額定輸出力矩 3 Times of Rated Output Torque					
急停扭矩 Emergency Stop Torque									
額定輸入轉速 Rated Input Speed	n_{IN}	rpm	125 ~ 1000	3,000	3,000	3,000	3,000	3,000	2,000
最大輸入轉速 Max. Input Speed	n_{IB}	rpm	125 ~ 1000	6,000	6,000	5,000	5,000	4,000	3,000
背隙 Backlash Ps		arcmin	125 ~ 1000	-	-	≤ 5	≤ 5	≤ 5	≤ 5
背隙 Backlash P0		arcmin	125 ~ 1000	≤ 7	≤ 7	≤ 7	≤ 7	≤ 7	≤ 7
背隙 Backlash P1		arcmin	125 ~ 1000	≤ 9	≤ 9	≤ 9	≤ 9	≤ 9	≤ 9
背隙 Backlash P2		arcmin	125 ~ 1000	≤ 11	≤ 11	≤ 11	≤ 11	≤ 11	≤ 11
扭轉剛性 Torsional Rigidity		Nm/arcmin	125 ~ 1000	6	14	27	60	140	240
容許徑向力 Max. Radial Force	F_{2rB}	N	125 ~ 1000	1,180	3,200	6,800	9,300	15,600	51,000
容許軸向力 Max. Axial Force	F_{2aB}	N	125 ~ 1000	590	1,600	3,400	4,650	7,800	25,500
使用壽命 Service Life	L_H	hr	125 ~ 1000	S5 周期運轉 : >30,000 (S1 連續運轉 : >15,000 hrs) S5 Cycle Operation: >30,000 (S1 Continuous Operation: >15,000 hrs)					
效率 Efficiency	η	%	125 ~ 1000	≥ 90%					
使用溫度 Operating Temperature		°C	125 ~ 1000	- 25° C ~ + 90° C					
潤滑 Lubrication			125 ~ 1000	全合成潤滑油脂 Synthetic Grease					
防護等級 Protection Class			125 ~ 1000	IP65					
安裝方向 Mounting Position			125 ~ 1000	任意方向 Any					
噪音值 Noise Level		dB	125 ~ 1000	≤ 58	≤ 60	≤ 63	≤ 65	≤ 67	≤ 70
重量 Weight ±3%		Kg	125 ~ 1000	2.5	6.5	13	26	56.5	86

■ 轉動慣量 Mass Moments of Inertia (kg.cm²)

Ratio	62A	90A	120A	142A	180A	220A
125	0.01	0.01	0.04	0.71	1.42	3.29
150	0.01	0.01	0.04	0.51	0.92	2.15
175	0.01	0.01	0.04	0.4	0.83	1.26
200	0.01	0.01	0.04	0.21	0.65	0.98
250	0.01	0.01	0.04	0.11	0.52	0.82
300	0.01	0.01	0.04	0.09	0.21	0.82
350	0.01	0.01	0.04	0.09	0.21	0.82
400	0.01	0.01	0.04	0.09	0.21	0.82
450	0.01	0.01	0.04	0.09	0.21	0.51
500	0.01	0.01	0.04	0.08	0.12	0.51
600	0.01	0.01	0.04	0.08	0.12	0.25
700	0.01	0.01	0.04	0.08	0.12	0.25
800	0.01	0.01	0.04	0.08	0.12	0.25
900	0.01	0.01	0.04	0.08	0.12	0.25
1000	0.01	0.01	0.04	0.08	0.12	0.25