

SERVOBOX Planetary Reducers

MODEL : SE-A

雙段 2-Stage

RATIO : 15, 20, 25, 30, 35, 40, 50, 60, 70, 80, 90, 100

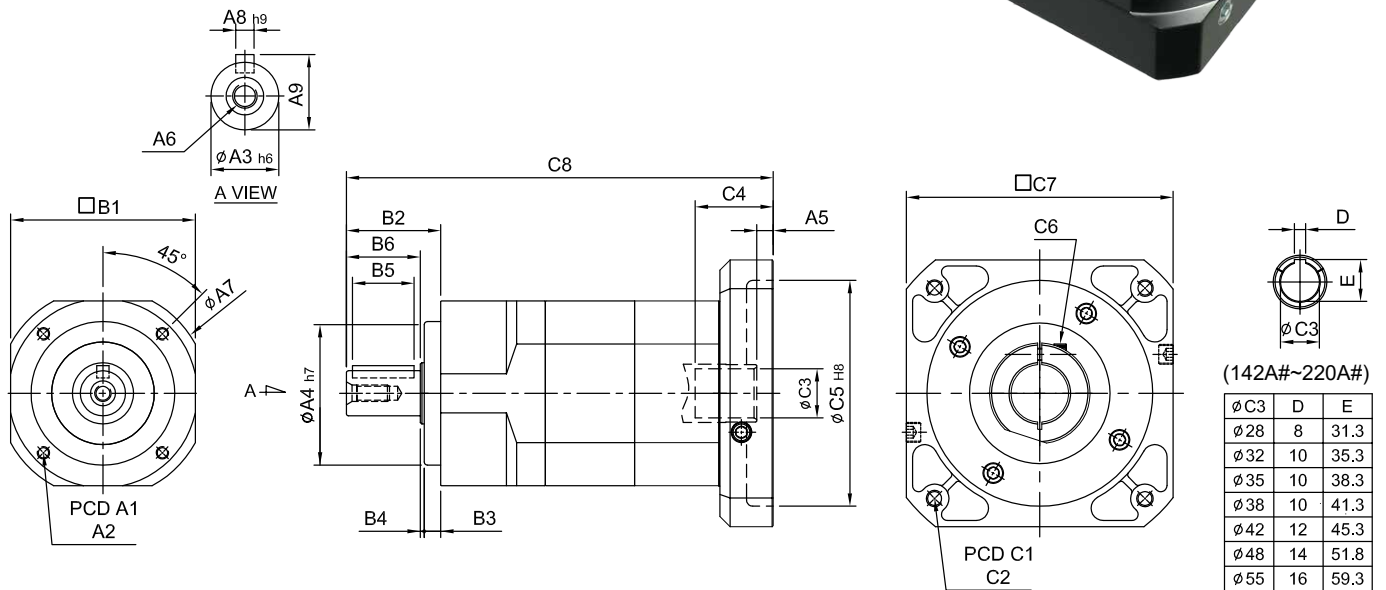

unit: mm

Model Code	44A	62A	90A	120A	142A	180A	220A
A	A1	44	62	82	110	140	218
	A2	M4 x P0.7	M5 x P0.8	M6 x P1.0	M8 x P1.25	M10 x P1.5	M12 x P1.75
	A3	13	16	22	32	40	75
	A4	35	50	70	90	120	180
	A5	5	6	9 · 23.5	10 · 20	10	11.5 · 13.5
	A6	M4 x P0.7	M5 x P0.8	M8 x P1.25	M10 x P1.5	M12 x P1.75	M14 x P2.0
	A7	50	70	102	134	166	215
	A8	5	5	6	10	12	16
	A9	15	18	24.5	35	43	59
B	B1	44	62	90	120	142	180
	B2	26	36	46	65	92	106
	B3	5	7	8	12	15	20
	B4	1	1	2	3	3	4
	B5	15	20	30	40	65	70
	B6	20	28	36	50	74	82
C	C1	46 · 60 · 63	70 · 75 · 90	90 · 100 · 115 · 145	115 · 145 · 165	145 · 165 · 215	200 · 215 · 265
	C2	M3 · M4 · M5	M4 · M5 · M6	M5 · M6 · M8	M6 · M8 · M10	M8 · M10 · M12	M10 · M12
	C3	8 · 9 · 11	11 · 14 · 16 · 19	16 · 19 · 22 · 24	22 · 24 · 28 · 32	28 · 32 · 35 · 38	35 · 38 · 42 · 48 · 55
	C4	26 · 30.5	33.5	59 · 73.5	67 · 77	84.5	114.5 · 116.5
	C5	30 · 40 · 50	50 · 60 · 70	70 · 80 · 95 · 110	95 · 110 · 130	110 · 130 · 180	114.3 · 180 · 230
	C6	M4 x P0.7	M5 x P0.8	M6 x P1.0	M8 x P1.25	M10 x P1.5	M10 x P1.5
	C7	46 · 55	64 · 70 · 80	92 · 110 · 130	122 · 130 · 150	146 · 150 · 190	182 · 200 · 250
	C8	121	148.8	208 · 222.5	261 · 271	327	404.5

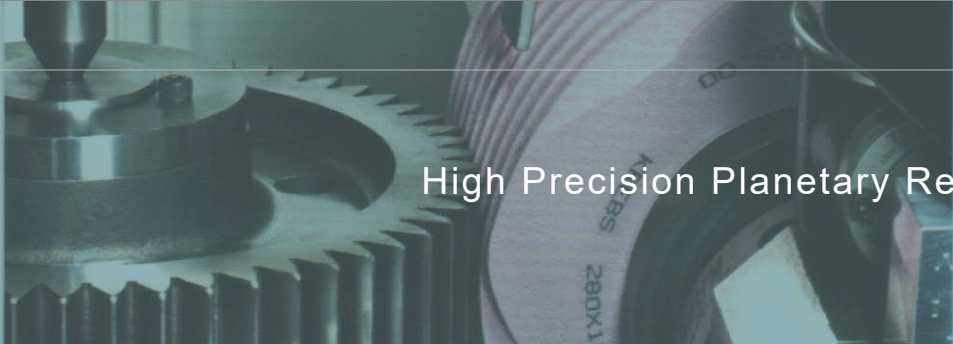

High Precision Planetary Reducer

規格 Parameter	代號	單位 Unit	速比 Ratio	44A	62A	90A	120A	142A	180A	220A
額定輸出扭矩 Rated Output Torque (Nominal output torque)	T_{2N}	Nm	15	19	59	165	335	625	1,206	2,030
			20	16	51	146	300	555	1,069	1,804
			25	16	48	160	333	618	1,189	2,010
			30	15	45	151	311	583	1,118	1,911
			35	15	45	149	309	573	1,108	1,870
			40	14	43	143	298	553	1,070	1,824
			50	16	48	160	333	618	1,189	2,010
			60	15	45	151	311	583	1,118	1,911
			70	15	45	149	309	573	1,108	1,870
			80	14	43	143	298	553	1,070	1,824
90	13	44	145	278	516	993	1,694			
100	14	43	141	294	549	1,059	1,779			
最大加速扭矩 Max. Acceleration Torque	T_{2B}	Nm	15 ~ 100	1.8 倍額定輸出力矩 1.8 Times of Rated Output Torque						
最大輸出扭矩 Max. Output Torque 急停扭矩 Emergency Stop Torque	T_{2NOT}	Nm	15 ~ 100	3 倍額定輸出力矩 3 Times of Rated Output Torque						
額定輸入轉速 Rated Input Speed	n_{IN}	rpm	15 ~ 100	3,000	3,000	3,000	3,000	3,000	3,000	2,000
最大輸入轉速 Max. Input Speed	n_{IB}	rpm	15 ~ 100	6,000	6,000	6,000	5,000	5,000	4,000	3,000
背隙 Backlash Ps		arcmin	15 ~ 100	-	-	-	≤ 3	≤ 3	≤ 3	≤ 3
背隙 Backlash P0		arcmin	15 ~ 100	≤ 5	≤ 5	≤ 5	≤ 5	≤ 5	≤ 5	≤ 5
背隙 Backlash P1		arcmin	15 ~ 100	≤ 7	≤ 7	≤ 7	≤ 7	≤ 7	≤ 7	≤ 7
背隙 Backlash P2		arcmin	15 ~ 100	≤ 9	≤ 9	≤ 9	≤ 9	≤ 9	≤ 9	≤ 9
扭轉剛性 Torsional Rigidity		Nm/arcmin	15 ~ 100	3	6	14	27	60	140	240
容許徑向力 Max. Radial Force	F_{2rB}	N	15 ~ 100	380	1,180	3,200	6,800	9,300	15,600	51,000
容許軸向力 Max. Axial Force	F_{2aB}	N	15 ~ 100	190	590	1,600	3,400	4,650	7,800	25,500
使用壽命 Service Life	L_H	hr	15 ~ 100	S5 周期運轉 : >30,000 (S1 連續運轉 : >15,000 hrs) S5 Cycle Operation: >30,000 (S1 Continuous Operation: >15,000 hrs)						
效率 Efficiency	η	%	15 ~ 100	≥ 94%						
使用溫度 Operating Temperature		°C	15 ~ 100	- 25° C ~ + 90° C						
潤滑 Lubrication			15 ~ 100	全合成潤滑油脂 Synthetic Grease						
防護等級 Protection Class			15 ~ 100	IP65						
安裝方向 Mounting Position			15 ~ 100	任意方向 Any						
噪音值 Noise Level		dB	15 ~ 100	≤ 56	≤ 58	≤ 60	≤ 63	≤ 65	≤ 67	≤ 70
重量 Weight ±3%		Kg	15 ~ 100	0.9	2	6	10.2	22.5	42	59

■ 轉動慣量 Mass Moments of Inertia (kg.cm²)

Ratio	44A	62A	90A	120A	142A	180A	220A
15	0.03	0.14	0.46	2.63	7.30	22.79	56.98
20	0.03	0.14	0.46	2.63	7.30	22.79	56.98
25	0.03	0.14	0.46	2.63	7.10	22.79	56.98
30	0.03	0.14	0.46	2.43	7.10	22.59	56.48
35	0.03	0.14	0.44	2.43	7.10	22.59	56.48
40	0.03	0.14	0.44	2.43	6.92	22.59	56.48
50	0.03	0.14	0.44	2.39	6.92	22.59	56.48
60	0.03	0.14	0.43	2.39	6.72	21.83	54.58
70	0.03	0.14	0.43	2.39	6.72	21.83	54.58
80	0.03	0.14	0.43	2.39	6.72	21.83	54.58
90	0.03	0.14	0.40	2.39	6.72	21.60	54.00
100	0.03	0.14	0.40	2.39	6.72	21.60	54.00