

SERVOBOX Planetary Reducers

MODEL : SBL

雙段 2-Stage

RATIO : 15, 20, 25, 30, 35, 40, 50, 60, 70,
80, 90, 100, 120, 140, 160, 180, 200

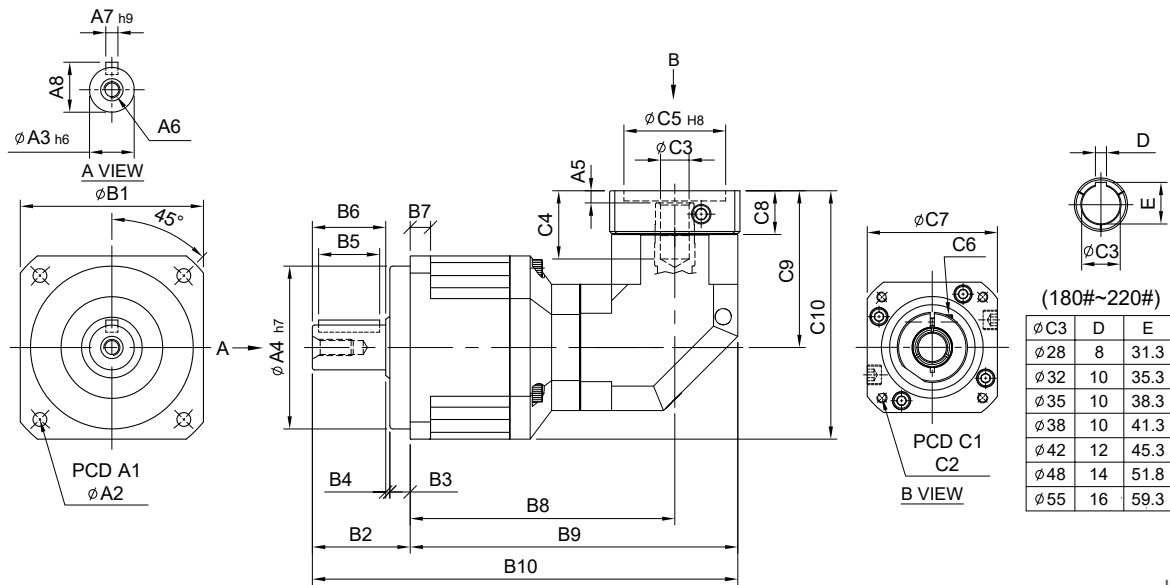
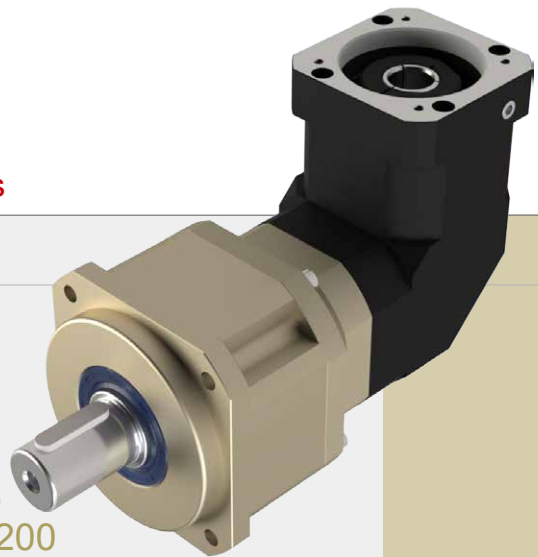

unit: mm

Model Code	62	90	120	142	180	220	
A	A1	70	100	130	165	215	250
	A2	5.5	6.8	9	11	13	17
	A3	16	22	32	40	55	75
	A4	50	80	110	130	160	180
	A5	6	6	9 · 23.5	10 · 20	10	12.5 · 14.5
	A6	M5 x P0.8	M8 x P1.25	M10 x P1.5	M12 x P1.75	M14 x P2.0	M16 x P2.0
	A7	5	6	10	12	16	20
	A8	18	24.5	35	43	59	79.5
B	B1	62	90	120	142	180	220
	B2	36	48	65	92	106	139
	B3	7	10	12	15	20	30
	B4	1	2	3	3	4	5
	B5	20	30	40	65	70	90
	B6	28	36	50	74	82	104
	B7	8	10	12	15	16	20
	B8	110.5	130	181.6	214.5	249.5	313.6
	B9	132.5	161	266.6	274.5	320.5	403.6
	B10	168.5	209	291.6	366.5	426.5	542.6
C	C1	46 · 60 · 63	70 · 75 · 90	90 · 110 · 115 · 145	115 · 145 · 165	145 · 165 · 215	200 · 215 · 265
	C2	M3 · M4 · M5	M4 · M5 · M6	M5 · M6 · M8 · M10	M6 · M8 · M10	M8 · M10 · M12	M10 · M12 · M16
	C3	8 · 11	11 · 14 · 16 · 19	16 · 19 · 22 · 24	24 · 28 · 32	28 · 32 · 35 · 38	35 · 38 · 42 · 48 · 55
	C4	27	33.5 · 42	53 · 58 · 67.5	67 · 77	67 · 84	117 · 119
	C5	30 · 40 · 50	50 · 60 · 70	70 · 80 · 95 · 110	95 · 110 · 130	110 · 130 · 180	114.3 · 180 · 230
	C6	M4 x P0.7	M5 x P0.8	M6 x P1.0	M8 x P1.25	M10 x P1.5	M10 x P1.5
	C7	46 · 55	64 · 70 · 80	92 · 110 · 130	122 · 130 · 150	146 · 150 · 190	182 · 200 · 250
	C8	16	21.5	26.5 · 41	35.5 · 45.5	35.5	45.5 · 47.5
	C9	61	77 · 85	115.3 · 129.8	141 · 151	165.7	235 · 237
	C10	92	122 · 130	175.3 · 189.8	212 · 222	255.7	345 · 347

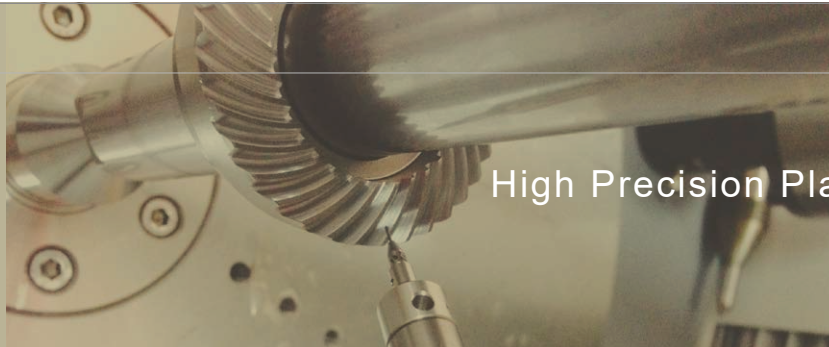

High Precision Planetary Reducer

規格 Parameter	代號	單位 Unit	速比 Ratio	62	90	120	142	180	220
額定輸出扭矩 Rated Output Torque (Nominal output torque)	T_{2N}	Nm	15	59	165	335	625	1,206	2,030
			20	51	146	300	555	1,069	1,804
			25	48	160	333	618	1,189	2,010
			30	45	151	311	583	1,118	1,911
			35	45	149	309	573	1,108	1,870
			40	43	143	298	553	1,070	1,824
			50	48	160	333	618	1,189	2,010
			60	45	151	311	583	1,118	1,911
			70	45	149	309	573	1,108	1,870
			80	43	143	298	553	1,070	1,824
			90	44	145	278	516	993	1,694
			100	43	141	294	549	1,059	1,779
			120	45	151	311	583	1,118	1,911
			140	45	149	309	573	1,108	1,870
			160	43	143	298	553	1,070	1,824
180	44	145	278	516	993	1,694			
200	43	141	294	549	1,059	1,779			
最大加速扭矩 Max. Acceleration Torque	T_{2B}	Nm	15 ~ 200	1.8 倍額定輸出力矩 1.8 Times of Rated Output Torque					
最大輸出扭矩 Max. Output Torque 急停扭矩 Emergency Stop Torque	T_{2NOT}	Nm	15 ~ 200	3 倍額定輸出力矩 3 Times of Rated Output Torque					
額定輸入轉速 Rated Input Speed	n_{1N}	rpm	15 ~ 200	3,000	3,000	3,000	3,000	3,000	2,000
最大輸入轉速 Max. Input Speed	n_{1B}	rpm	15 ~ 200	6,000	6,000	5,000	5,000	4,000	4,000
背隙 Backlash Ps		arcmin	15 ~ 200	-	≤ 4	≤ 4	≤ 4	≤ 4	≤ 4
背隙 Backlash P0		arcmin	15 ~ 200	≤ 7	≤ 7	≤ 7	≤ 7	≤ 7	≤ 7
背隙 Backlash P1		arcmin	15 ~ 200	≤ 9	≤ 9	≤ 9	≤ 9	≤ 9	≤ 9
背隙 Backlash P2		arcmin	15 ~ 200	≤ 12	≤ 12	≤ 12	≤ 12	≤ 12	≤ 12
扭轉剛性 Torsional Rigidity		Nm/arcmin	15 ~ 200	6	14	27	60	140	240
容許徑向力 Max. Radial Force	F_{2rB}	N	15 ~ 200	1,180	3,200	6,800	9,300	15,600	51,000
容許軸向力 Max. Axial Force	F_{2aB}	N	15 ~ 200	590	1,600	3,400	4,650	7,800	25,500
使用壽命 Service Life	L_H	hr	15 ~ 200	S5 周期運轉 : >30,000 (S1 連續運轉 : >15,000 hrs) S5 Cycle Operation: >30,000 (S1 Continuous Operation: >15,000 hrs)					
效率 Efficiency	η	%	15 ~ 200	≥ 92%					
使用溫度 Operating Temperature		°C	15 ~ 200	- 25° C ~ + 90° C					
潤滑 Lubrication			15 ~ 200	全合成潤滑油脂 Synthetic Grease					
防護等級 Protection Class			15 ~ 200	IP65					
安裝方向 Mounting Position			15 ~ 200	任意方向 Any					
噪音值 Noise Level		dB	15 ~ 200	≤ 68	≤ 70	≤ 72	≤ 74	≤ 76	≤ 78
重量 Weight ±3%		Kg	15 ~ 200	2	5.5	12.5	23.2	44.4	79.5

■ 轉動慣量 Mass Moments of Inertia (kg.cm²)

Ratio	62	90	120	142	180	220
15	0.09	0.36	2.28	6.85	26.2	70.1
20	0.09	0.36	2.28	6.85	26.2	70.1
25	0.09	0.36	2.28	6.85	23.1	68.2
30	0.09	0.36	2.28	6.85	23.1	68.2
35	0.09	0.36	2.28	6.85	23.1	68.2
40	0.09	0.36	2.28	6.85	23.1	68.2
50	0.09	0.36	2.28	6.85	23.1	68.2
60	0.09	0.36	2.28	6.85	23.1	68.2
70	0.09	0.36	2.28	6.85	23.1	68.2
80	0.09	0.36	2.28	6.85	23.1	68.2
90	0.09	0.36	2.28	6.85	23.1	68.2
100	0.09	0.36	2.28	6.85	23.1	68.2
120	0.03	0.10	1.88	6.20	21.2	65.1
140	0.03	0.10	1.88	6.20	21.2	65.1
160	0.03	0.10	1.88	6.20	21.2	65.1
180	0.03	0.10	1.88	6.20	21.2	65.1
200	0.03	0.10	1.88	6.20	21.2	65.1