

# HY series

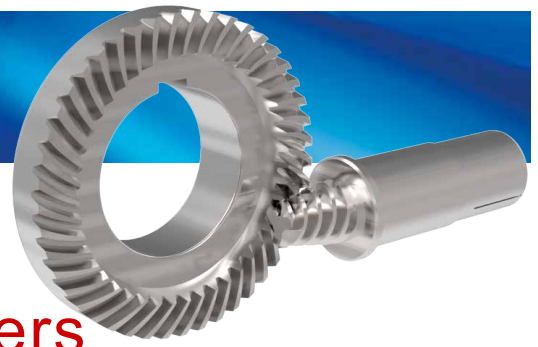

HY

## Indication of Model Numbers

機種型號表示

HY	55	F	O	B	5	L	P0
減速機機型 Type	型號 Model	入力表示 Input	出力表示 Output	軸承形式 Bearing	速比 Ratio	軸向 Shaft Direction	背隙等級 Backlash Class
HY	55 75 90 115 130 140 160 190 230 270	F: 入力法蘭 Input Flange R44: 減速機 Reducer 1-Stage: R44、R62... 2-Stage: R62S... 2-Stage (A-Type): R44A、R62A... D: 單入力軸心 (有鍵槽) Single Input Shaft (Keyway) D1: 單入力軸心 (無鍵槽) Single Input Shaft (No Keyway)	O: 出力中空軸 Hollow Output Shaft N: 單邊免鍵軸套 Single Clamping M: 雙邊免鍵軸套 Double Clamping S: 單出力軸心 (有鍵槽) Single Output Shaft (Keyway) S1: 單出力軸心 (無鍵槽) Single Output Shaft (No Keyway) V: 雙出力軸心 (有鍵槽) Double Output Shaft (Keyway) V1: 雙出力軸心 (無鍵槽) Double Output Shaft (No Keyway) P: 螺桿式 (75#~190#) Ball Screw 限用滾錐軸承 Taper Bearing Only	B: 滾珠軸承 Ball Bearing (55#~270#) T: 滾錐軸承 Taper Bearing (90#~270#)	單段 1-Stage 5, 10, 15 ----- 搭配單段 行星減速機 With 1-Stage Planetary Reducer 25 ~ 150 ----- 搭配雙段 行星減速機 With 2-Stage Planetary Reducer 250 ~ 1500	L: 左軸 Left Shaft R: 右軸 Right Shaft ----- 1. 出力形式 N、 S 可以選擇軸向 Shaft direction is optional for output type N, S. ----- 2. 出力形式 P 為 R 軸向 Output type P only for R shaft.	P0 P1 P2

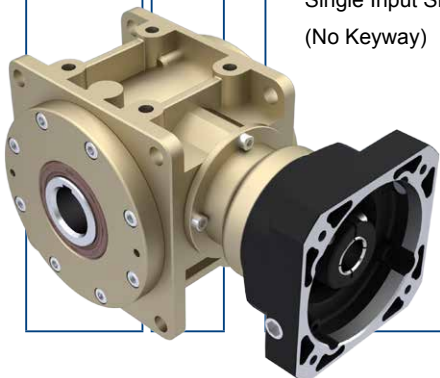

## The Model & Ratio Table of Hypoid Gear Reducer Assembly Planetary Reducer 蝕齒輪減速機搭配行星減速機型號及速比一覽表

型號 Model	減速比 Ratio	法蘭盤框號 Flange Model	減速機框號 Planetary Reducer Model	單段行星減速機減速比 Ratio of 1-Stage Planetary Reducer 5、10	雙段行星減速機減速比 Ratio of 2-Stage Planetary Reducer 25、50、100
55	5 10 15	44	44	搭配單段行星減速機減速比 Ratio of Bevel Gear Reducer with 1-Stage Planetary Reducer  25、50、75、100、150	搭配雙段行星減速機減速比 Ratio of Bevel Gear Reducer with 2-Stage Planetary Reducer  250、500、750、1000、1500
75		62	62		
90		90	80		
115		90	90		
130		120	120		
140		142	142		
160		142	142		
190		180	180		
230		180	180		
270		220	220		

# Selection of Type

## 產品樣式選擇

### 入力形式 Input Type

F 入力法蘭  
Input Flange

R 減速機  
Reducer

D 單入力軸心  
Single Input Shaft

O  
出力中空軸  
Hollow  
Output  
Shaft



FO



RO



DO

N  
單邊  
免鍵軸套  
Single  
Clamping



FN



RN



DN

M  
雙邊  
免鍵軸套  
Double  
Clamping



FM



RM



DM

S  
單出力軸心  
Single  
Output Shaft



FS



RS

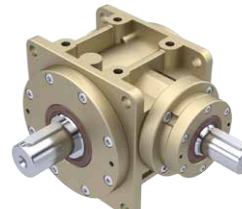

DS

V  
雙出力軸心  
Double  
Output Shaft



FV



RV



DV

P  
螺桿式  
Ball Screw



FP



RP



DP

出力形式

Output Type

- 出力形式 N、S 可以選擇軸向。Shaft direction is optional for output type N, S.
- 出力形式 P 為 R 軸向。Output type P only for R shaft.

# Rotating Direction

## 旋轉方向說明

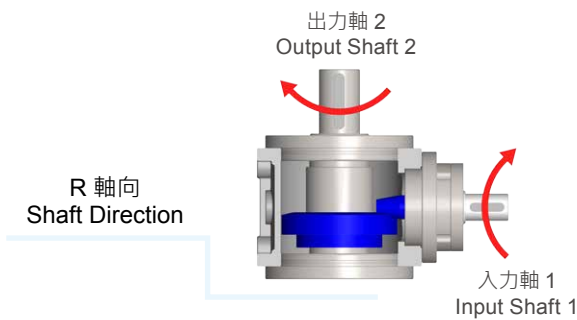
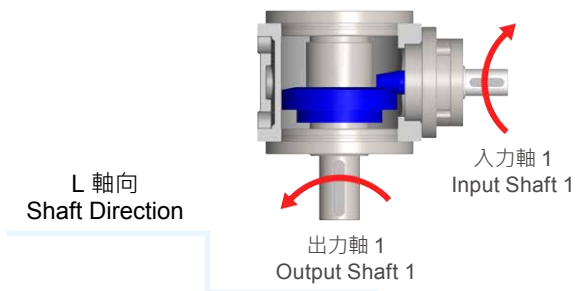
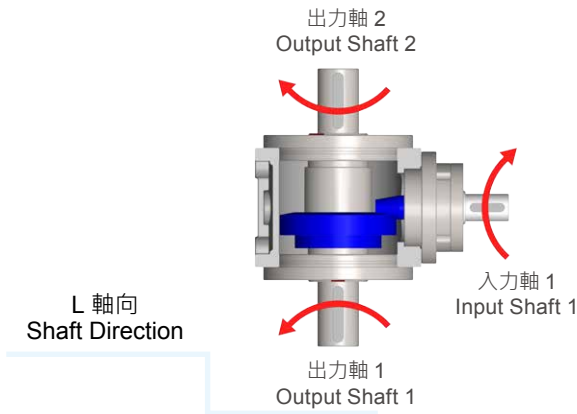
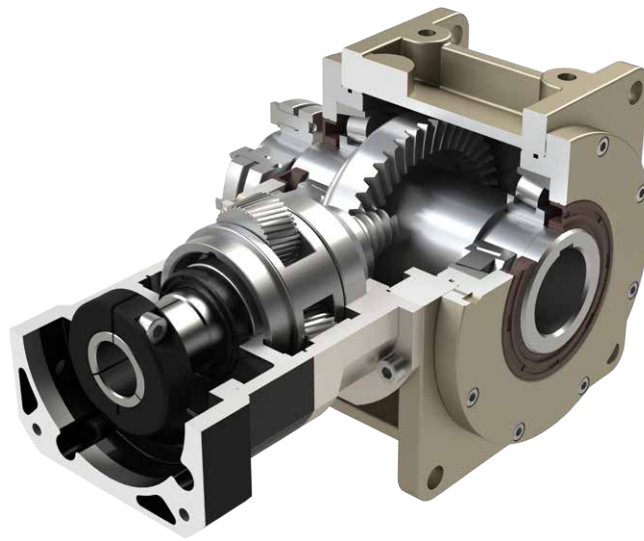

Note:  
本公司出廠標準品使用「標準軸向」，R 軸向請於訂單上註明。  
Standard product is L shaft direction, R shaft direction is optional.

# Selection Direction of Installation

## 安裝方向選擇

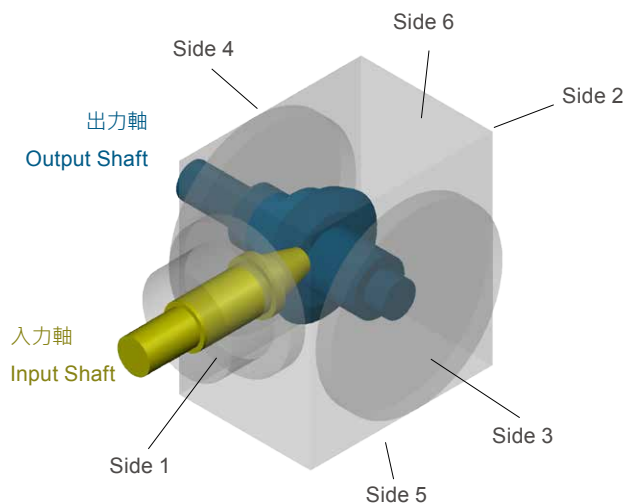

Side 1	Side 2
Side 3	Side 4 [Note 1]
Side 5	Side 6

[ Note 1 ] 出力軸端面基準線朝上時，需特別告知其使用方式。  
Side 4 operation shall be avoid.



# Features of HY Series

## HY 系列產品特點

HY

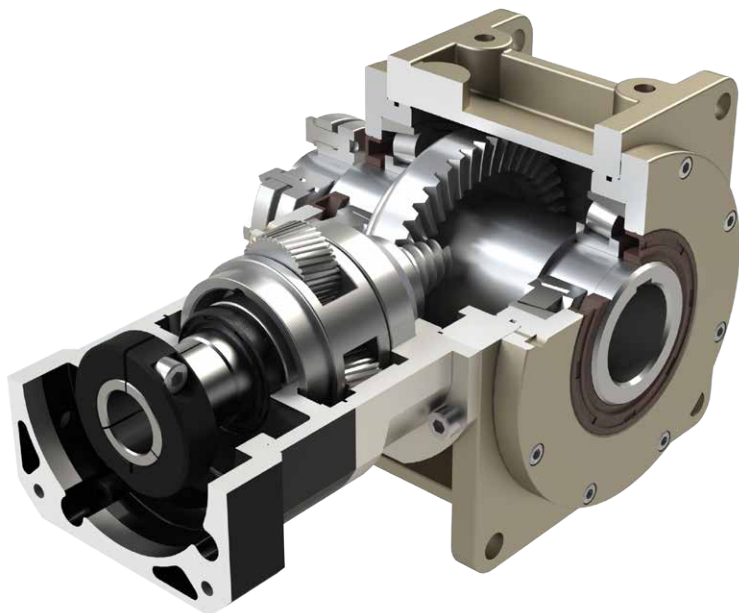

在設計 HYGear 時，已充分考慮到它將運用在及其廣泛的領域中。特別是在高動力伺服驅動應用中，將帶給用戶獨一無二的優勢。  
**Strong Performance for the HY Series**  
 The best solutions for almost every high torque application.

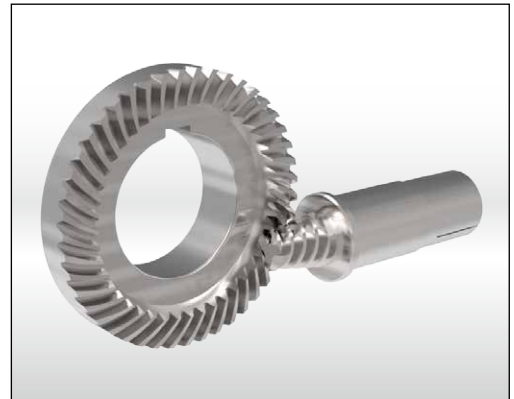

### 單級高減速比

- 格里森高減速比軟齒輪，標準品單級可達 1/15。
- 可訂製減速比單級 1/20~1/60。

### Super-Reduction-Hypoid Gear

- Gleason super-reduction-hypoid gear tooth system, the max. single stage ratio is 1/15.
- Single stage ratio 1/20~1/60 is optional.

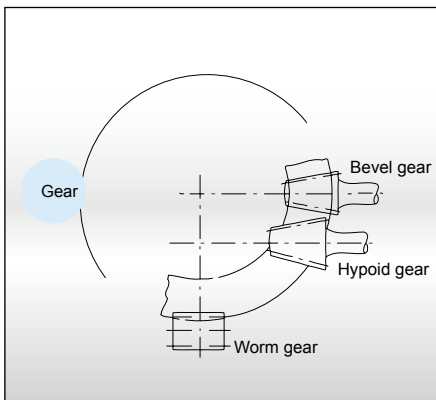

### 高扭矩密度

- 一體式齒箱本體確保最大剛性與耐蝕性。
- 結構緊湊，富有剛性的設計保證了在小體積、重量輕的情況下能夠達到最高扭矩及較大的減速比。

### High Output Torque

- The gear box is one-piece constructed to ensure the high rigidity and corrosion-resistant capability.

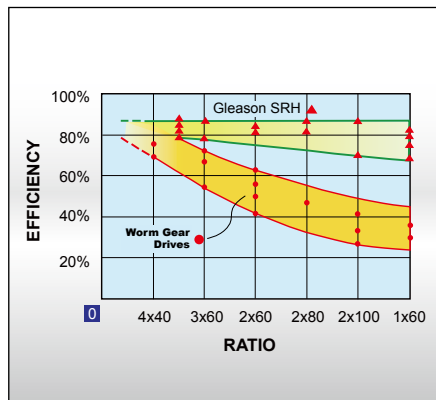

### 高扭矩密度

- 減速機的效率高達 90% 大大節省能源成本。

### High Output Torque

- High running efficiency, the efficiency more then 90%.

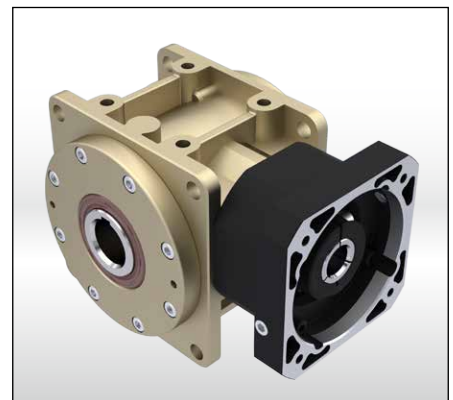

### 免保養

- 免保養無須更換潤滑油，運轉壽命長。

### No Maintenance

- It features no maintenance and long service life.

# Features of HY Series

## HY 系列產品特點



### 低背隙

- 使用 Gleason 參數齒輪加工設備，加工研磨等級的螺旋傘齒輪，確保低背隙、低噪音。
- 背隙最小可達 2 弧分以內。

### Low Backlash

- Using Gleason high precision CNC grinding machine to grinding the spiral bevel gears.
- Torsional backlash depending on design up to <2 arcmin

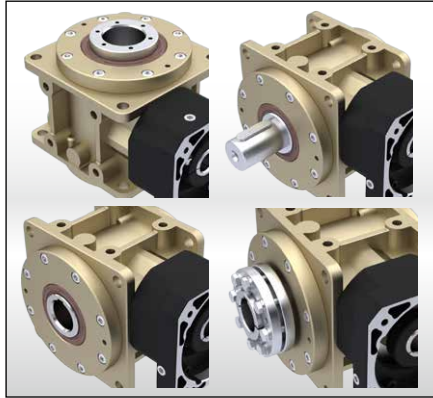

### 安裝位置

- 多重精密加工表面易於組裝，適用於任意安裝方向。
- 入出力軸的設計可以適用於各種工業上應用的需求。

### Mounting Position

- Multiple precision machined surface is easy for assembly, suitable for any optional mounting orientation.
- Output shaft and input shaft are designed to suit for various industries applications.

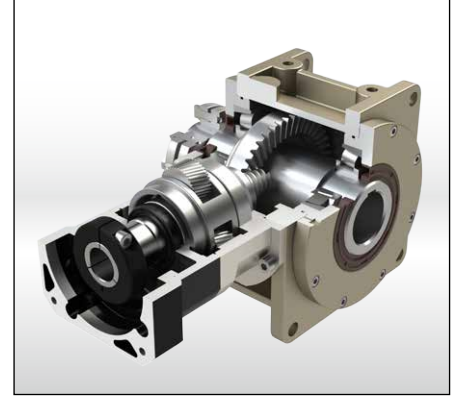

### 更高的減速比

- 高精密研磨的蝸線傘齒輪組結合最佳化設計的行星式齒輪組可以達到 1500:1 的減速比。

### More High Gear Ratio

- High precision grinded and carburized spiral bevel gears with optimal designed planetary gear can do ratio 1500: 1.

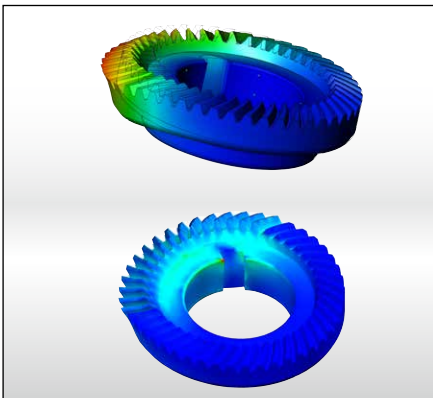

### CAE 設計分析技術

- 利用 3D-CAE 軟體的設計分析技術，對減速機整體強度及螺旋傘齒輪進行分析，增加齒輪系及減速機的使用壽命。

### CAE Design and Analysis

- Employs 3D-CAE software for analysis and design, the software allows for analyzing the strength of the entire gear reducer and helical teeth. Increasing the service life of gears and the gear reducer.

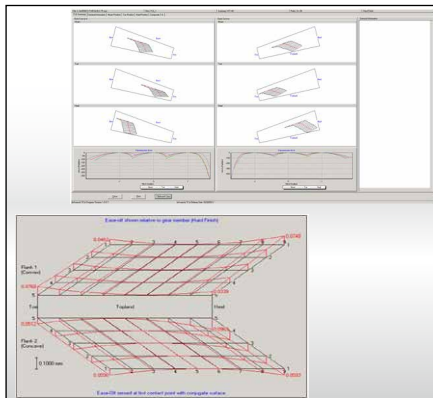

### 最優化的設計

- 採用 Gleason 參數齒輪設計軟件，得到最佳化接觸面積的齒印參數，保證了最高扭矩以及最小噪音。

### Optimized Design

- Use Gleason's design software to design new spiral bevel gears. Through the ideal gear contact pattern for application, achieve high permissible output torque.

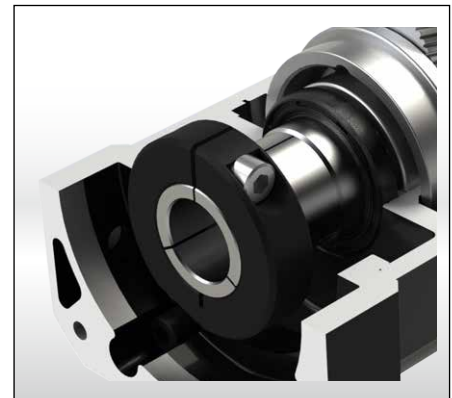

### 筒夾式連結機構

- 輸入端與馬達的連結採用筒夾式的鎖緊機構，並經動平衡分析，以確保在高輸入轉速下結合界面的同心度和平衡度，及零背隙的動力傳遞。

### Collet Locking Mechanism

- The input-end and the motor are coupled through a collet locking mechanism. It has passed dynamical balance analysis to assure concentricity and balance on the connection and no backlash for power transmission while running at high speed.

# Characteristic of HY Series

## HY 系列產品特性

### 單段減速機 1-Stage

規格 Parameter	Code	Unit	Ratio	55	75	90	115	130	140	160	190	230	270
額定輸出扭矩 / Rated Output Torque (Nominal output torque)	$T_{2N}$	Nm	5	35	70	140	260	430	720	1,100	1,440	2,090	2,720
			10	30	60	117	220	365	615	957	1,230	1,710	2,200
			15	25	50	95	180	300	510	815	1,020	1,418	1,906
最大加速扭矩 / Max. Acceleration Torque	$T_{2B}$	Nm	5~15	1.5 倍額定輸出扭矩 1.5 Times of Rated Output Torque									
最大輸出扭矩 / Max. Output Torque 急停扭矩 / Emergency Stop Torque	$T_{2NOT}$	Nm	5~15	2 倍額定輸出扭矩 2 Times of Rated Output Torque									
額定輸入轉速 / Nominal Input Speed	$n_{1N}$	rpm	5	2,100	1,800	1,500	1,150	1,000	700	600	550	500	400
			10	3,200	2,700	2,200	1,800	1,500	1,200	1100	1,000	900	800
			15	3,900	3,300	2,800	2,300	2,000	1,600	1,350	1,300	1,100	1,000
最大輸入轉速 / Max. Input Speed	$n_{1B}$	rpm	5~15	6,000	6,000	6,000	6,000	5,000	5,000	4,000	4,000	4,000	4,000
背隙 / Backlash	$J_t$	arcmin	P0	-	-	≤ 3	≤ 3	≤ 3	≤ 3	≤ 3	≤ 3	≤ 3	≤ 3
			P1	≤ 6	≤ 6	≤ 6	≤ 6	≤ 6	≤ 6	≤ 6	≤ 6	≤ 6	≤ 6
			P2	≤ 9	≤ 9	≤ 9	≤ 9	≤ 9	≤ 9	≤ 9	≤ 9	≤ 9	≤ 9
輸出的背隙剛性 / Backlash Stiffness at the Output	$C_{t21}$	Nm/ arcmin	5~15	2.1	4.2	10.5	23.4	39.6	61.8	90.0	126.0	167.0	218.0
容許徑向力 / Max. Radial Force 滾珠軸承 Ball Bearing	$F_{2rB}$	N	5~15	1,495	2,366	2,691	4,797	5,837	7,020	9,490	12,337	15,500	17,360
容許軸向力 / Max. Axial Force 滾珠軸承 Ball Bearing	$F_{2aB}$	N	5~15	748	1,183	1,346	2,399	2,919	3,510	4,745	6,169	7,750	8,680
容許徑向力 / Max. Radial Force 滾錐軸承 Taper Bearing	$F_{2rB}$	N	5~15	-	5,000	6,545	9,100	12,320	14,420	18,620	24,080	30,800	33,600
容許軸向力 / Max. Axial Force 滾錐軸承 Taper Bearing	$F_{2aB}$	N	5~15	-	2,500	3,273	4,550	6,160	7,210	9,310	12,040	15,400	16,800
使用壽命 / Service Life	$L_{H1}$	hr	5~15	S5 周期運轉 Cycle Operation: >30,000									
滿載傳動效率 / Efficiency Rating at full Load	$\eta$	%	5~10	≥ 96%									
			15	≥ 93%									
使用溫度 / Operating Temperature		°C	5~15	-10°C ~ +90°C									
潤滑 / Lubrication			5~15	全合成潤滑油 Synthetic Oil									
噪音值 / Noise Level ( $n_1=3000 \text{ min}^{-1}$ )		dB	5~15	≤ 67	≤ 67	≤ 69	≤ 69	≤ 71	≤ 71	≤ 72	≤ 72	≤ 74	≤ 76

### 轉動慣量 Mass Moments of Inertia (kgcm<sup>2</sup>)

Ratio	55	75	90	115	130	140	160	190	230	270
5	0.23	0.58	1.41	4.00	7.12	13.53	24.76	44	63	69
10	0.15	0.38	1.00	2.46	4.27	7.38	12.47	21	56	57
15	0.13	0.34	0.81	2.07	3.45	5.76	9.23	16	52	50

# Characteristic of HY Series

## HY 系列產品特性

### 雙段減速機 2-Stage

規格 Parameter	Code	Unit	Ratio	55	75	90	115	130	140	160	190	230	270
額定輸出扭矩 / Rated Output Torque (Nominal output torque)	$T_{2N}$	Nm	25, 50	35	70	140	260	430	720	1,100	1,440	2,090	2,720
			100	30	60	117	220	365	615	957	1,230	1,710	2,200
			75,150	25	50	95	180	300	510	815	1,020	1,418	1,906
最大加速扭矩 / Max. Acceleration Torque	$T_{2B}$	Nm	25~150	1.5 倍額定輸出扭矩 1.5 Times of Rated Output Torque									
最大輸出扭矩 / Max. Output Torque 急停扭矩 / Emergency Stop Torque	$T_{2NOT}$	Nm	25~150	2 倍額定輸出扭矩 2 Times of Rated Output Torque									
額定輸入轉速 / Nominal Input Speed	$n_{1N}$	rpm	25~150	3,500	3,000	3,000	2,500	2,500	2,500	2,500	2,500	2,000	2,000
最大輸入轉速 / Max. Input Speed	$n_{1B}$	rpm	25~150	6,000	6,000	6,000	6,000	5,000	5,000	4,000	4,000	4,000	4,000
背隙 / Backlash	$J_t$	arcmin	P0	-	-	≤ 4	≤ 4	≤ 4	≤ 4	≤ 4	≤ 4	≤ 4	≤ 4
			P1	≤ 7	≤ 7	≤ 7	≤ 7	≤ 7	≤ 7	≤ 7	≤ 7	≤ 7	≤ 7
			P2	≤ 10	≤ 10	≤ 10	≤ 10	≤ 10	≤ 10	≤ 10	≤ 10	≤ 10	≤ 10
輸出的背隙剛性 / Backlash Stiffness at the Output	$C_{t21}$	Nm/ arcmin	25~150	2.1	4.1	10.2	22.8	37.8	60.1	86.5	119.2	167.0	218.0
容許徑向力 / Max. Radial Force 滾珠軸承 Ball Bearing	$F_{2rB}$	N	25~150	1,495	2,366	2,691	4,797	5,837	7,020	9,490	12,337	15,500	17,360
容許軸向力 / Max. Axial Force 滾珠軸承 Ball Bearing	$F_{2aB}$	N	25~150	748	1,183	1,346	2,399	2,919	3,510	4,745	61,69	7,750	8,680
容許徑向力 / Max. Radial Force 滾錐軸承 Taper Bearing	$F_{2rB}$	N	25~150	-	5,000	6,545	9,100	12,320	14,420	18,620	24,080	30,800	33,600
容許軸向力 / Max. Axial Force 滾錐軸承 Taper Bearing	$F_{2aB}$	N	25~150	-	2,500	3,273	4,550	6,160	7,210	9,310	12,040	15,400	16,800
使用壽命 / Service Life	$L_H$	hr	25~150	S5 周期運轉 Cycle Operation: >30,000									
滿載傳動效率 / Efficiency Rating at full Load	$\eta$	%	25~150	≥ 92%									
使用溫度 / Operating Temperature		°C	25~150	-10°C ~ +90°C									
潤滑 / Lubrication			25~150	全合成潤滑油 Synthetic Oil									
噪音值 / Noise Level ( $n_1=3000 \text{ min}^{-1}$ )		dB	25~150	≤ 67	≤ 67	≤ 69	≤ 69	≤ 71	≤ 71	≤ 72	≤ 72	≤ 74	≤ 76

### 轉動慣量 Mass Moments of Inertia ( $\text{kgcm}^2$ )

Ratio	55	75	90	115	130	140	160	190	230	270
25	0.39	1.15	1.18	4.9	4.99	7.99	8.27	8.75	53.27	53.27
50	0.36	1.05	1.06	4.07	4.09	6.31	6.36	6.45	50.56	50.56
75	0.35	0.94	0.96	3.17	3.24	4.04	4.23	4.56	53.27	53.27
100	0.34	0.93	0.94	3.12	3.14	3.87	3.92	4.01	50.56	50.56
150	0.33	0.92	0.93	3.08	3.06	3.73	3.68	3.59	50.56	50.56



# HY-FO series

RATIO : 5.10.15 ( 單段 1-Stage)

入力法蘭 - 出力中空軸

Input Flange - Hollow Output Shaft

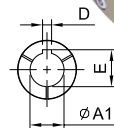
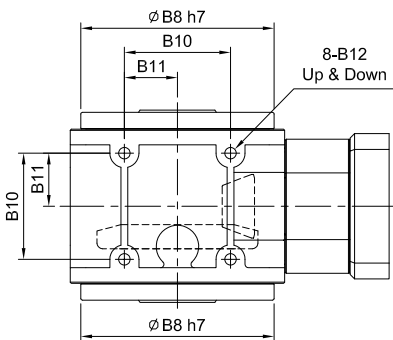
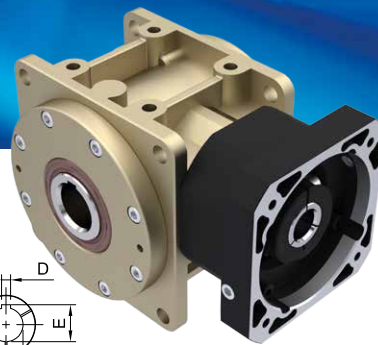

(140#~270#)

$\phi A1$	D	E
$\phi 32$	10	35.3
$\phi 35$	10	38.3
$\phi 38$	10	41.3
$\phi 42$	12	45.3
$\phi 48$	14	51.8
$\phi 55$	16	59.3
$\phi 60$	18	64.4
$\phi 65$	18	69.4

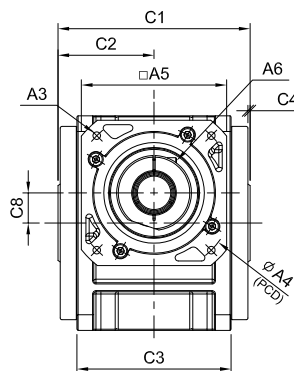
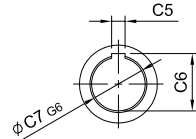
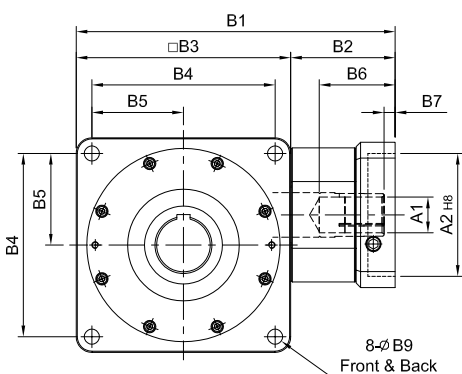

unit: mm

Model Code	55	75	90	115	130	140	160	190	230	270
	A1	8 · 11 · 14	14	14 · 19 · 24	19 · 22 · 24	24 · 28 · 32	32 · 35 · 38	32 · 35 · 38	42 · 48 · 55	42 · 48 · 55 · 60
A2	30 · 40 · 50	50 · 60 · 70	50 · 70 · 80 · 95	70 · 80 · 95 · 110	95 · 110 · 130	110 · 130 · 180	110 · 130 · 180	114.3 · 180 · 230 · 250	114.3 · 180 · 230 · 250	114.3 · 180 · 230 · 250
A3	M3 · M4 · M5	M4 · M5 · M6	M5 · M6	M5 · M6 · M8	M6 · M8 · M10	M8 · M10 · M12	M8 · M10 · M12	M12 · M16	M12 · M16	M12 · M16
A4	46 · 60 · 63	70 · 75 · 90	70 · 90 · 100 · 115	90 · 100 · 115 · 145	115 · 145 · 165	145 · 165 · 200	145 · 165 · 200	200 · 215 · 265 · 300	200 · 215 · 265 · 300	200 · 215 · 265 · 300
A5	46 · 55	64 · 70 · 80	80 · 92 · 110	92 · 110 · 130	122 · 130 · 150	146 · 150 · 190	146 · 150 · 190	182 · 200 · 250 · 265	182 · 200 · 250 · 265	222 · 220 · 250 · 265
A6	M3 x P.05	M5 x P0.8	M5 x P0.8	M6 x P1.0	M8 x P1.25	M10 x P1.5	M10 x P1.5	M10 x P1.5	M10 x P1.5	M10 x P1.5 · M12 x P1.75
B1	135	172	202 · 221 · 206.5	241	286	333	358	417 · 419	470 · 473	515.5 · 518.5 · 545
B2	45	57	62 · 81 · 66.5	71	94	118	118	153 · 155	170 · 173	165.5 · 168.5 · 195
B3	90	115	140	170	192	215	240	264	300	350
B4	78	98	118	144	164	182	206	224	260	300
B5	39	49	59	72	82	91	103	112	130	150
B6	28 · 33	38	49 · 68.5 · 54	58	69.5	81.5	81.5	114.5 · 116.5	112 · 115 · 120 · 123	112.5 · 115.5 · 142
B7	5	6	9 · 23.5	8	10	10	10	11.5 · 13.5	12 · 15	12.5 · 15.5 · 42
B8	84	103	128	148	173	200	227	254	295	328
B9	6.8	9	11	11	13.5	15	17.5	17.5	17.5	22
B10	44	54	66	80	95	104	120	140	180	200
B11	22	27	33	40	47.5	52	60	70	90	100
B12	M6 x P1.0	M8 x P1.25	M10 x P1.5	M12 x P1.75	M12 x P1.75	M14 x P2.0	M16 x P2.0	M16 x P2.0	M16 x P2.0	M20 x P2.0
C1	88	108	132	156	172	187	212	242	298	332
C2	44	54	66	78	86	93.5	106	121	149	166
C3	60	80	100	120	138	146	166	196	250	280
C4	2	2	2	2	2	2	2	2	3	3
C5	6	8	8	12	14	16	18	20	22	25
C6	22.8	28.3	33.3	43.3	51.8	59.3	64.3	74.9	85.4	95.4
C7	20	25	30	40	48	55	60	70	80	90
C8	9	14	18	23	27	32	38	42	50	56
Weight ±3% (kg)	2.2	4.1	7.9	13.2	18.6	27.3	38.3	54.3		

# HY-RO series

RATIO : 25.50.75.100.150 ( 雙段 2-Stage)

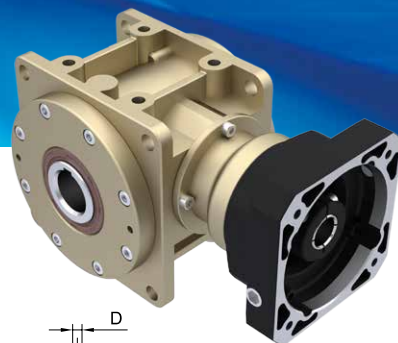

搭配行星減速機 - 出力中空軸

Fitted with Planetary Reducer - Hollow Output Shaft

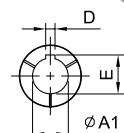
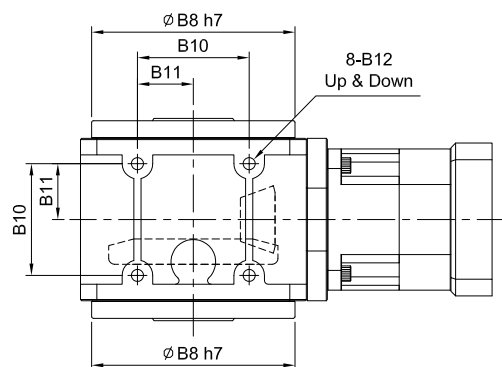

(140#~270#)

ØA1	D	E
Ø28	8	31.3
Ø32	10	35.3
Ø35	10	38.3
Ø38	10	41.3
Ø42	12	45.3
Ø48	14	51.8
Ø55	16	59.3

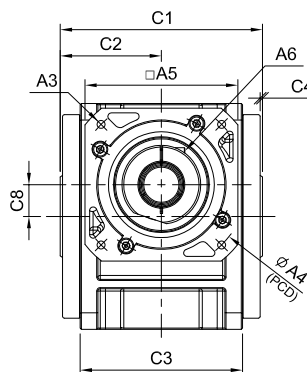
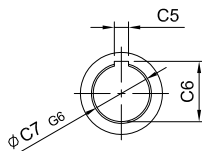
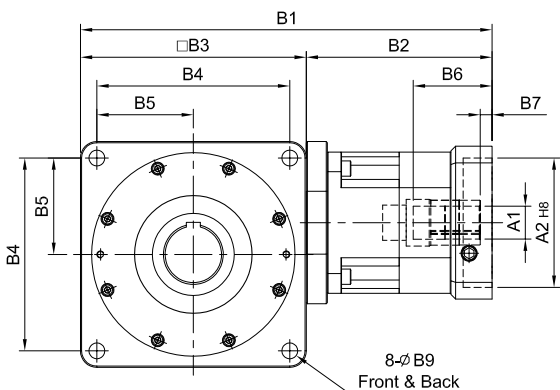

unit: mm

Model Code	55	75	90	115	130	140	160	190	230	270	
A	A1	8 · 9 · 11 · 14	11 · 14 · 16 · 19	(14) · 16 · 19	16 · 19 · 22 · 24	22 · 24 · 28 · 32 · 35	28 · 32 · 35 · 38	28 · 32 · 35 · 38	35 · 38 · 42 · 48 · 55	35 · 38 · 42 · 48 · 55	38 · 42 · 48 · 55
	A2	30 · 40 · 50	50 · 60 · 70	50 · 70 · 80 · 95	70 · 80 · 95 · 110	95 · 110 · 130	110 · 130 · 180	110 · 130 · 180	114.3 · 180 · 230 · 250	114.3 · 180 · 230 · 250	114.3 · 180 · 230 · 250
	A3	M3 · M4 · M5	M4 · M5 · M6	M5 · M6	M5 · M6 · M8	M6 · M8 · M10	M8 · M10 · M12	M8 · M10 · M12	M12 · M16	M12 · M16	M12 · M16
	A4	46 · 60 · 63	70 · 75 · 90	70 · 90 · 100 · 115	90 · 100 · 115 · 145	115 · 145 · 165	145 · 165 · 200	145 · 165 · 200	200 · 215 · 265 · 300	200 · 215 · 265 · 300	200 · 215 · 265 · 300
	A5	46 · 55	64 · 70 · 80	80 · 92 · 110	92 · 110 · 130	122 · 130 · 150	146 · 150 · 190	146 · 150 · 190	182 · 200 · 250 · 265	182 · 200 · 250 · 265	222 · 220 · 250 · 265
	A6	M3 x P.05	M5 x P.0.8	M5 x P.0.8	M6 x P.1.0	M8 x P.1.25	M10 x P.1.5	M10 x P.1.5	M10 x P.1.5	M10 x P.1.5	M10 x P.1.5
B	B1	157	201 · 209	(224.5) · 237	287	340 · 360	405	430	508 · 510	572	642.5
	B2	67	86 · 94	(84.5) · 97	117	148 · 168	190	190	244 · 246	272	292.5
	B3	90	115	140	170	192	215	240	264	300	350
	B4	78	98	118	144	164	182	206	224	260	300
	B5	39	49	59	72	82	91	103	112	130	150
	B6	26	33.5 · 41.5	(33.5) · 45.5	59	67 · 83	84.5	84.5	114.5 · 116.5	114.5	117.5
	B7	5	6	(6) · 10	9	10 · 11	10	10	11.5 · 13.5	11.5	12.5
	B8	84	103	128	148	173	200	227	254	295	328
	B9	6.8	9	11	11	13.5	15	17.5	17.5	17.5	22
	B10	44	54	66	80	95	104	120	140	180	200
	B11	22	27	33	40	47.5	52	60	70	90	100
	B12	M6 x P.1.0	M8 x P.1.25	M10 x P.1.5	M12 x P.1.75	M12 x P.1.75	M14 x P.2.0	M16 x P.2.0	M16 x P.2.0	M16 x P.2.0	M16 x P.2.0
C	C1	88	108	132	156	172	187	212	242	298	332
	C2	44	54	66	78	86	93.5	106	121	149	166
	C3	60	80	100	120	138	146	166	196	250	280
	C4	2	2	2	2	2	2	2	2	3	3
	C5	6	8	8	12	14	16	18	20	22	25
	C6	22.8	28.3	33.3	43.3	51.8	59.3	64.3	74.9	85.4	95.4
	C7	20	25	30	40	48	55	60	70	80	90
	C8	9	14	18	23	27	32	38	42	50	56
Weight ±3% (kg)	2.5	4.8	8.5	14.1	23.2	35.5	46.3	71.1			

# HY-DO series

RATIO : 5.10.15 ( 單段 1-Stage)

單入力軸心 - 出力中空軸

Single Input Shaft - Hollow Output Shaft

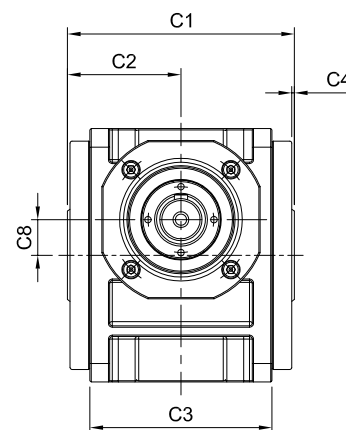
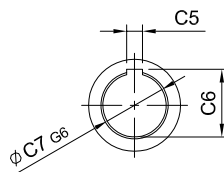
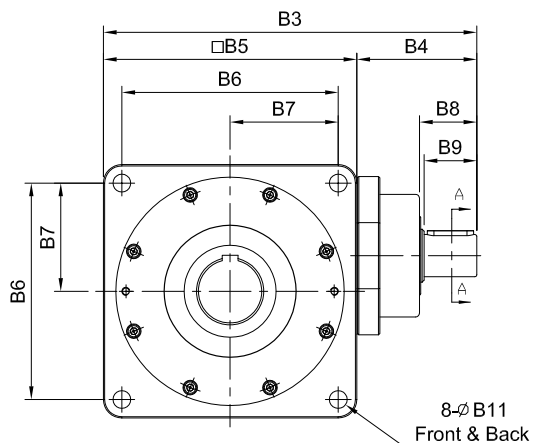
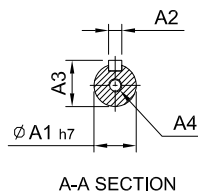
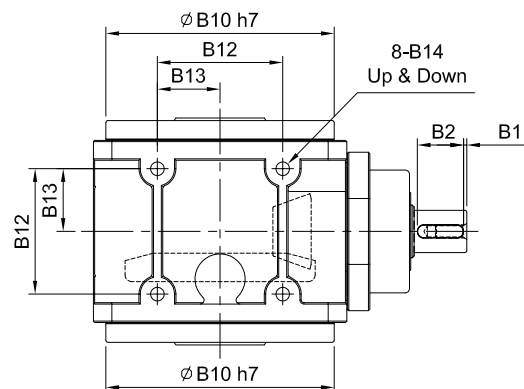
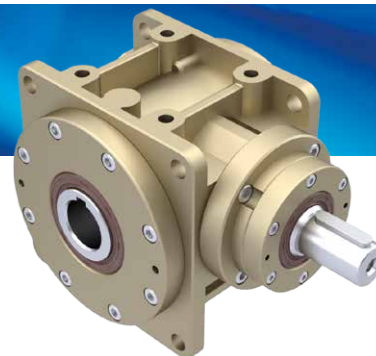

unit: mm

Model Code	55	75	90	115	130	140	160	190	230	270	
<b>A</b>	A1	14	19	24	28	32	32	38	40	55	60
	A2	5	6	8	8	10	10	12	12	16	18
	A3	16	21.5	27	31	35	35	41	43	59	64
	A4	M5 x P0.8	M6 x P1.0	M8 x P1.25	M10 x P1.5	M10 x P1.5	M10 x P1.5	M12 x P1.75	M12 x P1.75	M16 x P2.0	M16 x P2.0
<b>B</b>	B1	2.5	2.5	2.5	2.5	5	5	5	5	5	5
	B2	20	25	35	35	40	40	50	50	70	90
	B3	147	181	218	260	293	315	367	403	483	567
	B4	57	66	78	90	101	100	127	139	183	217
	B5	90	115	140	170	192	215	240	264	300	350
	B6	78	98	118	144	164	182	206	224	260	300
	B7	39	49	59	72	82	91	103	112	130	150
	B8	27	32	42.5	42.5	52.5	51.5	63	63.5	83	105
	B9	25	30	40	40	50	50	60	60	80	100
	B10	84	103	128	148	173	200	227	254	295	328
	B11	6.8	9	11	11	13.5	15	17.5	17.5	17.5	22
	B12	44	54	66	80	95	104	120	140	180	200
	B13	22	27	33	40	47.5	52	60	70	90	100
	B14	M6 x P1.0	M8 x P1.25	M10 x P1.5	M12 x P1.75	M12 x P1.75	M14 x P2.0	M16 x P2.0	M16 x P2.0	M16 x P2.0	M20 x P2.0
<b>C</b>	C1	88	108	132	156	172	187	212	242	298	332
	C2	44	54	66	78	86	93.5	106	121	149	166
	C3	60	80	100	120	138	146	166	196	250	280
	C4	2	2	2	2	2	2	2	2	3	3
	C5	6	8	8	12	14	16	18	20	22	25
	C6	22.8	28.3	33.3	43.3	51.8	59.3	64.3	74.9	85.4	95.4
	C7	20	25	30	40	48	55	60	70	80	90
	C8	9	14	18	23	27	32	38	42	50	56
Weight ±3% (kg)	2.9	4.6	8.4	13.7		27.7		54.5			

# HY-FN series

RATIO : 5.10.15 (單段 1-Stage)

入力法蘭 - 單邊免鍵軸套  
Input Flange - Single Clamping

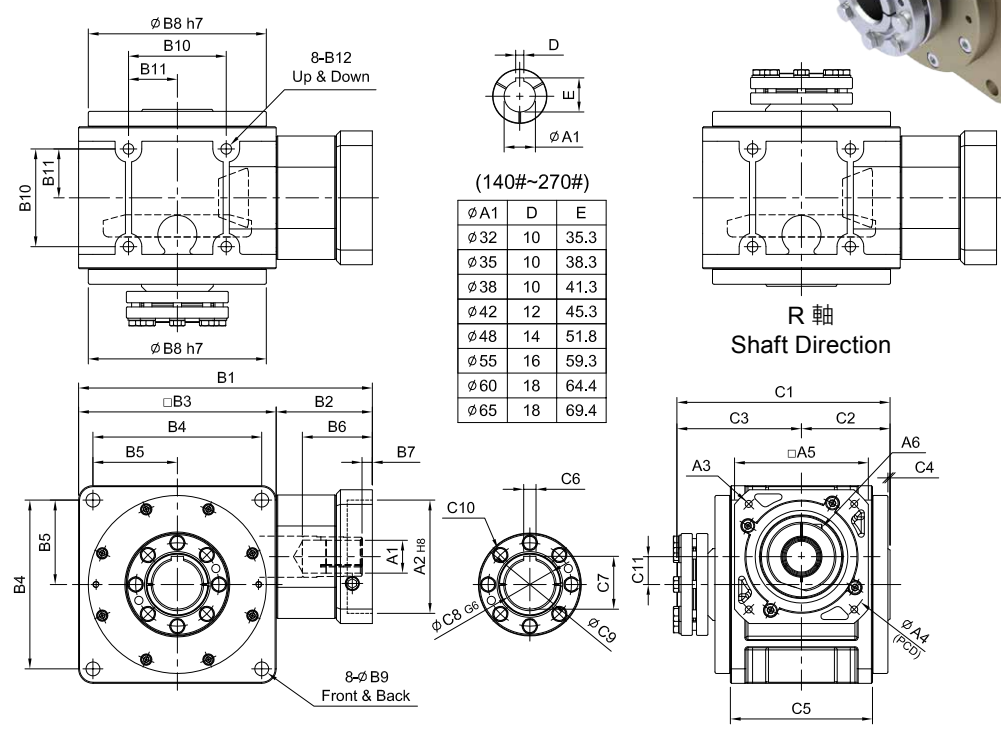
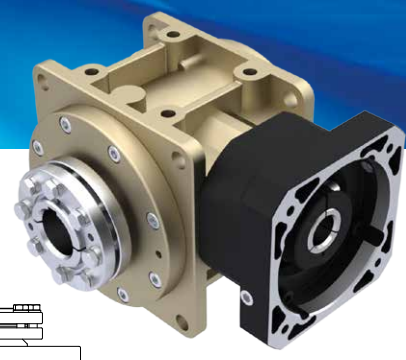

unit: mm

Model Code	55	75	90	115	130	140	160	190	230	270		
<b>A</b>	A1	8 · 11 · 14	14	14 · 19 · 24	19 · 22 · 24	24 · 28 · 32	32 · 35 · 38	32 · 35 · 38	42 · 48 · 55	42 · 48 · 55 · 60	48 · 55 · 60 · 65	
	A2	30 · 40 · 50	50 · 60 · 70	50 · 70 · 80 · 95	70 · 80 · 95 · 110	95 · 110 · 130	110 · 130 · 180	110 · 130 · 180	114.3 · 180 · 230 · 250	114.3 · 180 · 230 · 250	114.3 · 180 · 230 · 250	
	A3	M3 · M4 · M5	M4 · M5 · M6	M5 · M6	M5 · M6 · M8	M6 · M8 · M10	M8 · M10 · M12	M8 · M10 · M12	M12 · M16	M12 · M16	M12 · M16	
	A4	46 · 60 · 63	70 · 75 · 90	70 · 90 · 100 · 115	90 · 100 · 115 · 145	115 · 145 · 165	145 · 165 · 200	145 · 165 · 200	200 · 215 · 265 · 300	200 · 215 · 265 · 300	200 · 215 · 265 · 300	
	A5	46 · 55	64 · 70 · 80	80 · 92 · 110	92 · 110 · 130	122 · 130 · 150	146 · 150 · 190	146 · 150 · 190	182 · 200 · 250 · 265	182 · 200 · 250 · 265	222 · 220 · 250 · 265	
	A6	M3 x P.05	M5 x P.0.8	M5 x P.0.8	M6 x P.1.0	M8 x P.1.25	M10 x P.1.5	M10 x P.1.5	M10 x P.1.5	M10 x P.1.5	M10 x P.1.5	M10 x P.1.5 M12 x P.1.75
<b>B</b>	B1	135	172	202 · 221 · 206.5	241	286	333	358	417 · 419	470,473	515.5 · 518.5 · 545	
	B2	45	57	62 · 81 · 66.5	71	94	118	118	153 · 155	170 · 173	165.5 · 168.5 · 195	
	B3	90	115	140	170	192	215	240	264	300	350	
	B4	78	98	118	144	164	182	206	224	260	300	
	B5	39	49	59	72	82	91	103	112	130	150	
	B6	28 · 33	38	49 · 68.5 · 54	58	69.5	81.5	81.5	114.5 · 116.5	112 · 115 · 120 · 123	112.5 · 115.5 · 142	
	B7	5	6	9 · 23.5	8	10	10	10	11.5 · 13.5	12 · 15	12.5 · 15.5 · 42	
	B8	84	103	128	148	173	200	227	254	295	328	
	B9	6.8	9	11	11	13.5	15	17.5	17.5	17.5	22	
	B10	44	54	66	80	95	104	120	140	180	200	
	B11	22	27	33	40	47.5	52	60	70	90	100	
	B12	M6 x P.1.0	M8 x P.1.25	M10 x P.1.5	M12 x P.1.75	M12 x P.1.75	M14 x P.2.0	M16 x P.2.0	M16 x P.2.0	M16 x P.2.0	M20 x P.2.0	
<b>C</b>	C1	109	134	160	189	207	224	249	281	344	378	
	C2	44	54	66	78	86	93.5	106	121	149	166	
	C3	65	80	94	111	121	130.5	143	160	195	212	
	C4	2	2	2	2	2	2	2	2	3	3	
	C5	60	80	100	120	138	146	166	196	250	280	
	C6	6	8	8	12	14	16	18	20	22	25	
	C7	22.8	28.3	33.3	43.3	51.8	59.3	64.3	74.9	85.4	95.4	
	C8	20	25	30	40	48	55	60	70	80	90	
	C9	28	34	44	52	60	73	73	83	100	110	
	C10	6-M6	8-M6	8-M6	8-M6	8-M8	12-M8	12-M8	12-M8	12-M8	12-M10	12-M10
	C11	9	14	18	23	27	32	38	42	50	56	
Weight ±3% (kg)	2.5	4.5	8.7	13.5	18.5	29.4	40.6	57.7	86.56	121.5		



# HY-RN series

RATIO : 25.50.75.100.150 (雙段 2-Stage)

搭配行星減速機 - 單邊免鍵軸套

Fitted with Planetary Reducer - Single Clamping

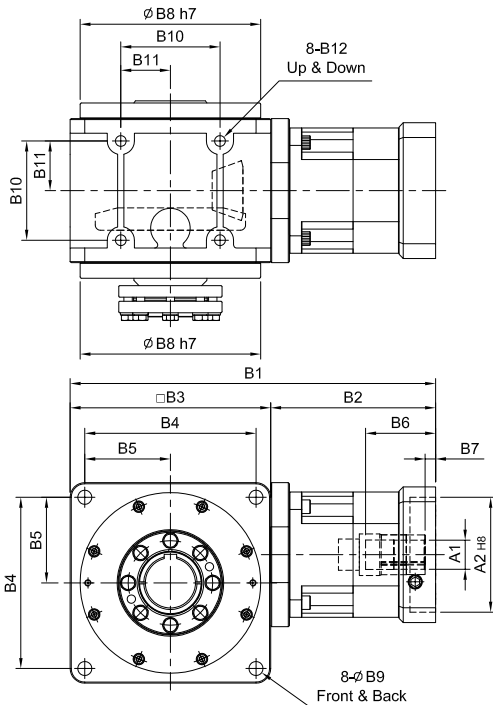
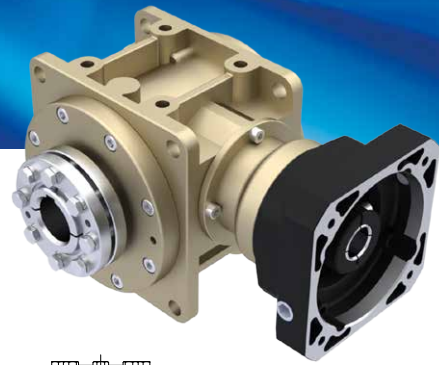

(140#~270#)

$\phi A1$	D	E
$\phi 28$	8	31.3
$\phi 32$	10	35.3
$\phi 35$	10	38.3
$\phi 38$	10	41.3
$\phi 42$	12	45.3
$\phi 48$	14	51.8
$\phi 55$	16	59.3

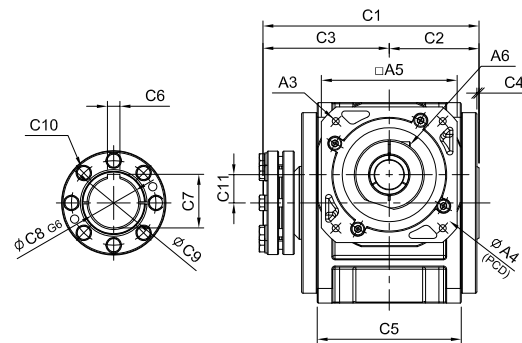
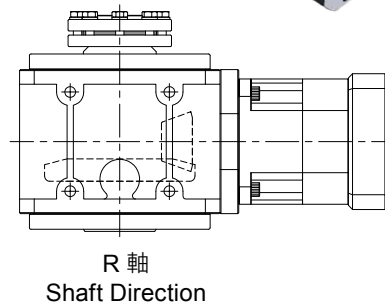

unit: mm

Model Code	55	75	90	115	130	140	160	190	230	270	
A	A1	8 · 9 · 11 · 14	11 · 14 · 16 · 19	(14) · 16 · 19	16 · 19 · 22 · 24	22 · 24 · 28 · 32 · 35	28 · 32 · 35 · 38	28 · 32 · 35 · 38	35 · 38 · 42 · 48 · 55	35 · 38 · 42 · 48 · 55	38 · 42 · 48 · 55
	A2	30 · 40 · 50	50 · 60 · 70	50 · 70 · 80 · 95	70 · 80 · 95 · 110	95 · 110 · 130	110 · 130 · 180	110 · 130 · 180	114.3 · 180 · 230 · 250	114.3 · 180 · 230 · 250	114.3 · 180 · 230 · 250
	A3	M3 · M4 · M5	M4 · M5 · M6	M5 · M6	M5 · M6 · M8	M6 · M8 · M10	M8 · M10 · M12	M8 · M10 · M12	M12 · M16	M12 · M16	M12 · M16
	A4	46 · 60 · 63	70 · 75 · 90	70 · 90 · 100 · 115	90 · 100 · 115 · 145	115 · 145 · 165	145 · 165 · 200	145 · 165 · 200	200 · 215 · 265 · 300	200 · 215 · 265 · 300	200 · 215 · 265 · 300
	A5	46 · 55	64 · 70 · 80	80 · 92 · 110	92 · 110 · 130	122 · 130 · 150	146 · 150 · 190	146 · 150 · 190	182 · 200 · 250 · 265	182 · 200 · 250 · 265	222 · 220 · 250 · 265
	A6	M3 x P.05	M5 x P0.8	M5 x P0.8	M6 x P1.0	M8 x P1.25	M10 x P1.5	M10 x P1.5	M10 x P1.5	M10 x P1.5	M10 x P1.5
B	B1	157	201 · 209	(224.5) · 237	287	340 · 360	405	430	508 · 510	572	642.5
	B2	67	86 · 94	(84.5) · 97	117	148 · 168	190	190	244 · 246	272	292.5
	B3	90	115	140	170	192	215	240	264	300	350
	B4	78	98	118	144	164	182	206	224	260	300
	B5	39	49	59	72	82	91	103	112	130	150
	B6	26	33.5 · 41.5	(33.5) · 45.5	59	67 · 83	84.5	84.5	114.5 · 116.5	114.5	117.5
	B7	5	6	(6) · 10	9	10 · 11	10	10	11.5 · 13.5	11.5	12.5
	B8	84	103	128	148	173	200	227	254	295	328
	B9	6.8	9	11	11	13.5	15	17.5	17.5	17.5	22
	B10	44	54	66	80	95	104	120	140	180	200
	B11	22	27	33	40	47.5	52	60	70	90	100
	B12	M6 x P1.0	M8 x P1.25	M10 x P1.5	M12 x P1.75	M12 x P1.75	M14 x P2.0	M16 x P2.0	M16 x P2.0	M16 x P2.0	M20 x P2.0
C	C1	109	134	160	189	207	224	249	281	344	378
	C2	44	54	66	78	86	93.5	106	121	149	166
	C3	65	80	94	111	121	130.5	143	160	195	212
	C4	2	2	2	2	2	2	2	2	3	3
	C5	60	80	100	120	138	146	166	196	250	280
	C6	6	8	8	12	14	16	18	20	22	25
	C7	22.8	28.3	33.3	43.3	51.8	59.3	64.3	74.9	85.4	95.4
	C8	20	25	30	40	48	55	60	70	80	90
	C9	28	34	44	52	60	73	73	83	100	110
	C10	6-M6	8-M6	8-M6	8-M6	8-M8	12-M8	12-M8	12-M8	12-M8	12-M10
	C11	9	14	18	23	27	32	38	42	50	56
Weight $\pm 3\%$ (kg)	2.9	5.4	8.9	15.2	24.1	37.5	48.2	73.2			



# HY-DN series

RATIO : 5.10.15 (單段 1-Stage)

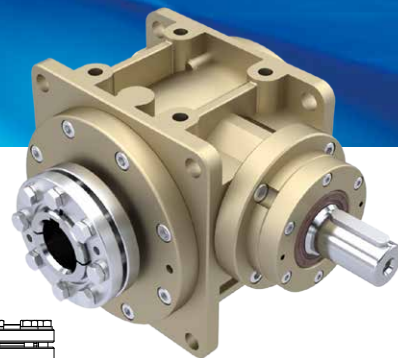

單入力軸心 - 單邊免鍵軸套

Single Input Shaft - Single Clamping

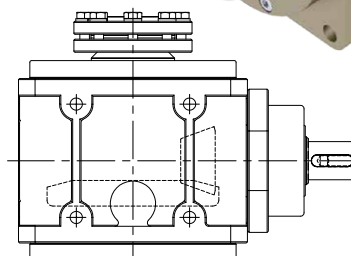
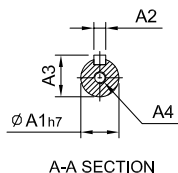
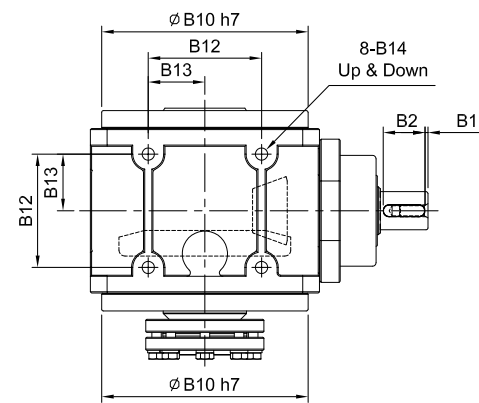

R 軸  
Shaft Direction

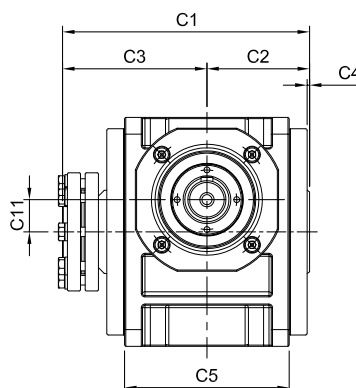
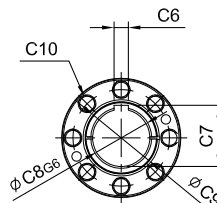
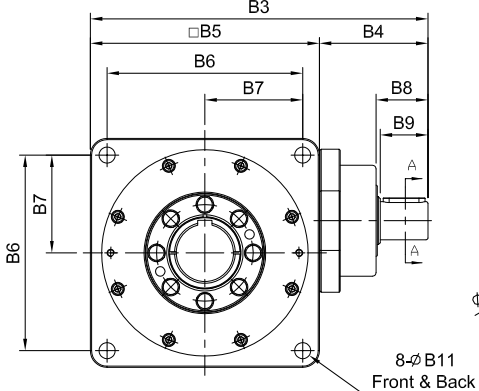

unit: mm

Model Code	55	75	90	115	130	140	160	190	230	270	
<b>A</b>	A1	14	19	24	28	32	32	38	40	55	60
	A2	5	6	8	8	10	10	12	12	16	18
	A3	16	21.5	27	31	35	35	41	43	59	64
	A4	M5 x P0.8	M6 x P1.0	M8 x P1.25	M10 x P1.5	M10 x P1.5	M10 x P1.5	M12 x P1.75	M12 x P1.75	M16 x P2.0	M16 x P2.0
<b>B</b>	B1	2.5	2.5	2.5	2.5	5	5	5	5	5	5
	B2	20	25	35	35	40	40	50	50	70	90
	B3	147	181	218	260	293	315	367	403	483	567
	B4	57	66	78	90	101	100	127	139	183	217
	B5	90	115	140	170	192	215	240	264	300	350
	B6	78	98	118	144	164	182	206	224	260	300
	B7	39	49	59	72	82	91	103	112	130	150
	B8	27	32	42.5	42.5	52.5	51.5	63	63.5	83	105
	B9	25	30	40	40	50	50	60	60	80	100
	B10	84	103	128	148	173	200	227	254	295	328
	B11	6.8	9	11	11	13.5	15	17.5	17.5	17.5	22
	B12	44	54	66	80	95	104	120	140	180	200
	B13	22	27	33	40	47.5	52	60	70	90	100
	B14	M6 x P1.0	M8 x P1.25	M10 x P1.5	M12 x P1.75	M12 x P1.75	M14 x P2.0	M16 x P2.0	M16 x P2.0	M16 x P2.0	M20 x P2.0
<b>C</b>	C1	109	134	160	189	207	224	249	281	344	378
	C2	44	54	66	78	86	93.5	106	121	149	166
	C3	65	80	94	111	121	130.5	143	160	195	212
	C4	2	2	2	2	2	2	2	2	3	3
	C5	60	80	100	120	138	146	166	196	250	280
	C6	6	8	8	12	14	16	18	20	22	25
	C7	22.8	28.3	33.3	43.3	51.8	59.3	64.3	74.9	85.4	95.4
	C8	20	25	30	40	48	55	60	70	80	90
	C9	28	34	44	52	60	73	73	83	100	110
	C10	6-M6	8-M6	8-M6	8-M6	8-M8	12-M8	12-M8	12-M8	12-M10	12-M10
	C11	9	14	18	23	27	32	38	42	50	56
Weight ±3% (kg)	3.2	5.0	9.2	14.8		28.5		54.8			

# HY-FM series

RATIO : 5.10.15 ( 單段 1-Stage)

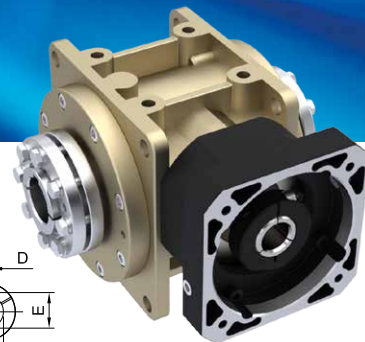

入力法蘭 - 雙邊免鍵軸套

Input Flange - Double Clamping

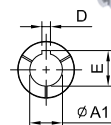
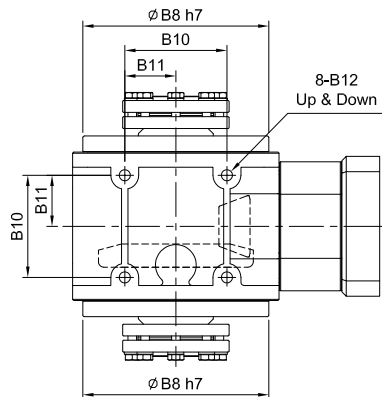

(140#~270#)

$\phi A1$	D	E
$\phi 32$	10	35.3
$\phi 35$	10	38.3
$\phi 38$	10	41.3
$\phi 42$	12	45.3
$\phi 48$	14	51.8
$\phi 55$	16	59.3
$\phi 60$	18	64.4
$\phi 65$	18	69.4

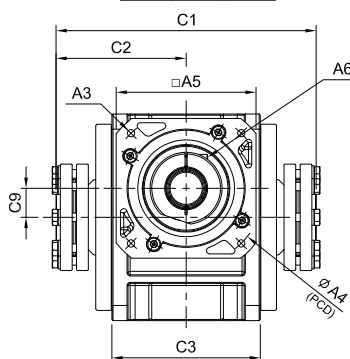
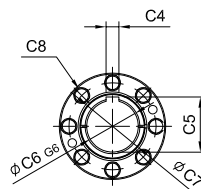
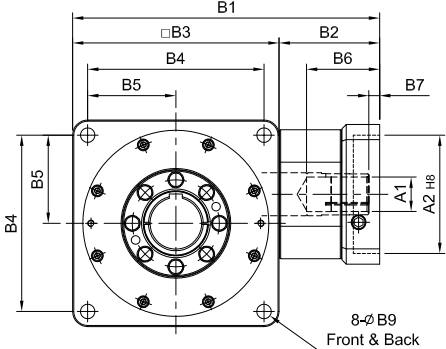

unit: mm

Model Code	55	75	90	115	130	140	160	190	230	270
A1	8 · 11 · 14	14	14 · 19 · 24	19 · 22 · 24	24 · 28 · 32	32 · 35 · 38	32 · 35 · 38	42 · 48 · 55	42 · 48 · 55 · 60	48 · 55 · 60 · 65
A2	30 · 40 · 50	50 · 60 · 70	50 · 70 · 80 · 95	70 · 80 · 95 · 110	95 · 110 · 130	110 · 130 · 180	110, 130, 180	114.3 · 180 · 230 · 250	114.3 · 180 · 230 · 250	114.3 · 180 · 230 · 250
A3	M3 · M4 · M5	M4 · M5 · M6	M5 · M6	M5 · M6 · M8	M6 · M8 · M10	M8 · M10 · M12	M8 · M10 · M12	M12 · M16	M12 · M16	M12 · M16
A4	46 · 60 · 63	70 · 75 · 90	70 · 90 · 100 · 115	90 · 100 · 115 · 145	115 · 145 · 165	145 · 165 · 200	145 · 165 · 200	200 · 215 · 265 · 300	200 · 215 · 265 · 300	200 · 215 · 265 · 300
A5	46 · 55	64 · 70 · 80	80 · 92 · 110	92 · 110 · 130	122 · 130 · 150	146 · 150 · 190	146 · 150 · 190	182 · 200 · 250 · 265	182 · 200 · 250 · 265	222 · 220 · 250 · 265
A6	M3 x P.05	M5 x P.0.8	M5 x P.0.8	M6 x P.1.0	M8 x P.1.25	M10 x P.1.5	M10 x P.1.5	M10 x P.1.5	M10 x P.1.5	M10 x P.1.5 M12 x P.1.75
B1	135	172	202 · 221 · 206.5	241	286	333	358	417 · 419	470, 473	515.5 · 518.5 · 545
B2	45	57	62 · 81 · 66.5	71	94	118	118	153 · 155	170 · 173	165.5 · 168.5 · 195
B3	90	115	140	170	192	215	240	264	300	350
B4	78	98	118	144	164	182	206	224	260	300
B5	39	49	59	72	82	91	103	112	130	150
B6	28 · 33	38	49 · 68.5 · 54	58	69.5	81.5	81.5	114.5 · 116.5	112 · 115 · 120 · 123	112.5 · 115.5 · 142
B7	5	6	9 · 23.5	8	10	10	10	11.5 · 13.5	12 · 15	12.5 · 15.5 · 42
B8	84	103	128	148	173	200	227	254	295	328
B9	6.8	9	11	11	13.5	15	17.5	17.5	17.5	22
B10	44	54	66	80	95	104	120	140	180	200
B11	22	27	33	40	47.5	52	60	70	90	100
B12	M6 x P.1.0	M8 x P.1.25	M10 x P.1.5	M12 x P.1.75	M12 x P.1.75	M14 x P.2.0	M16 x P.2.0	M16 x P.2.0	M16 x P.2.0	M20 x P.2.0
C1	130	160	188	222	242	261	286	320	390	424
C2	65	80	94	111	121	130.5	143	160	195	212
C3	60	80	100	120	138	146	166	196	250	280
C4	-	-	-	-	14	16	18	20	22	25
C5	-	-	-	-	51.8	59.3	64.3	74.9	85.4	95.4
C6	20	25	30	40	48	55	60	70	80	90
C7	28	34	44	52	60	73	73	83	100	110
C8	6-M6	8-M6	8-M6	8-M6	8-M8	12-M8	12-M8	12-M8	12-M10	12-M10
C9	9	14	18	23	27	32	38	42	50	56
Weight ±3% (kg)		4.8	8.2	15.2	19.5	30.7	41.5	59.7	92.97	

# HY-RM series

RATIO : 25.50.75.100.150 ( 雙段 2-Stage)

搭配行星減速機 - 雙邊免鍵軸套

Fitted with Planetary Reducer - Double Clamping

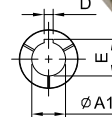
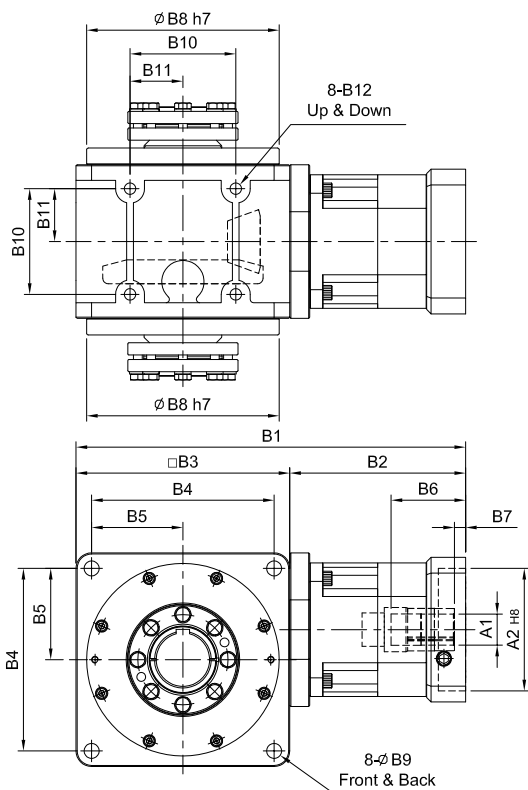

(140#~270#)

φA1	D	E
φ28	8	31.3
φ32	10	35.3
φ35	10	38.3
φ38	10	41.3
φ42	12	45.3
φ48	14	51.8
φ55	16	59.3

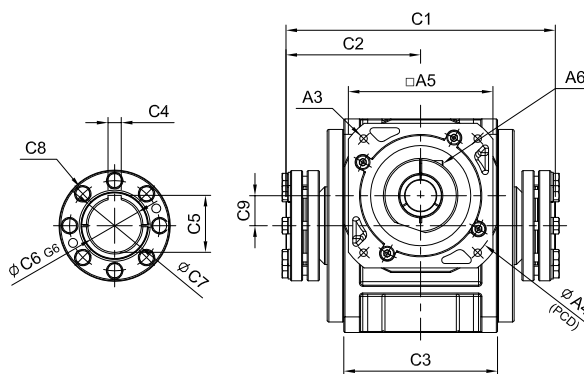

unit: mm

Model Code	55	75	90	115	130	140	160	190	230	270		
A	A1	8·9·11·14	11·14·16·19	(14)·16·19	16·19·22·24	22·24·28·32·35	28·32·35·38	28·32·35·38	35·38·42·48·55	35·38·42·48·55	38·42·48·55	
	A2	30·40·50	50·60·70	50·70·80·95	70·80·95·110	95·110·130	110·130·180	110·130·180	114.3·180·230·250	114.3·180·230·250	114.3·180·230·250	
	A3	M3·M4·M5	M4·M5·M6	M5·M6	M5·M6·M8	M6·M8·M10	M8·M10·M12	M8·M10·M12	M12·M16	M12·M16	M12·M16	
	A4	46·60·63	70·75·90	70·90·100·115	90·100·115·145	115·145·165	145·165·200	145·165·200	200·215·265·300	200·215·265·300	200·215·265·300	
	A5	46·55	64·70·80	80·92·110	92·110·130	122·130·150	146·150·190	146·150·190	182·200·250·265	182·200·250·265	222·220·250·265	
	A6	M3 x P.05	M5 x P0.8	M5 x P0.8	M6 x P1.0	M8 x P1.25	M10 x P1.5	M10 x P1.5	M10 x P1.5	M10 x P1.5	M10 x P1.5	
B	B1	157	201·209	(224.5)·237	287	340·360	405	430	508·510	572	642.5	
	B2	67	86·94	(84.5)·97	117	148·168	190	190	244·246	272	292.5	
	B3	90	115	140	170	192	215	240	264	300	350	
	B4	78	98	118	144	164	182	206	224	260	300	
	B5	39	49	59	72	82	91	103	112	130	150	
	B6	26	33.5·41.5	(33.5)·45.5	59	67·83	84.5	84.5	114.5·116.5	114.5	117.5	
	B7	5	6	(6)·10	9	10·11	10	10	11.5·13.5	11.5	12.5	
	B8	84	103	128	148	173	200	227	254	295	328	
	B9	6.8	9	11	11	13.5	15	17.5	17.5	17.5	22	
	B10	44	54	66	80	95	104	120	140	180	200	
	B11	22	27	33	40	47.5	52	60	70	90	100	
	B12	M6 x P1.0	M8 x P1.25	M10 x P1.5	M12 x P1.75	M12 x P1.75	M14 x P2.0	M16 x P2.0	M16 x P2.0	M16 x P2.0	M20 x P2.0	
C	C1	130	160	188	222	242	261	286	320	390	424	
	C2	65	80	94	111	121	130.5	143	160	195	212	
	C3	60	80	100	120	138	146	166	196	250	280	
	C4	-	-	-	-	14	16	18	20	22	25	
	C5	-	-	-	-	51.8	59.3	64.3	74.9	85.4	95.4	
	C6	20	25	30	40	48	55	60	70	80	90	
	C7	28	34	44	52	60	73	73	83	100	110	
	C8	6-M6	8-M6	8-M6	8-M6	8-M8	12-M8	12-M8	12-M8	12-M8	12-M10	12-M10
	C9	9	14	18	23	27	32	38	42	50	56	
Weight ±3% (kg)	3.2	5.7	9.9	16.4	25.7	39.4	50.7	74.4				



# HY-DM series

RATIO : 5.10.15 ( 單段 1-Stage)



單入力軸心 - 雙邊免鍵軸套

Single Input Shaft - Double Clamping

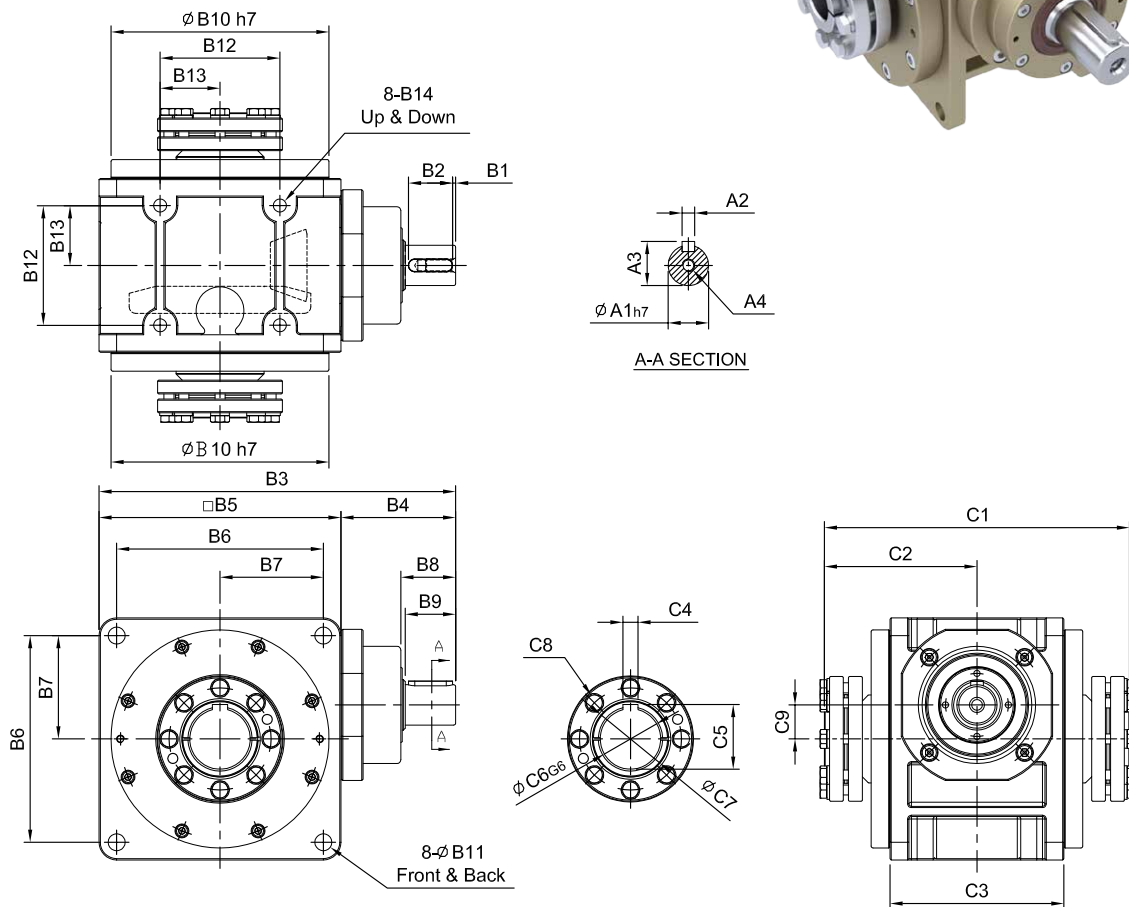

unit: mm

Model Code	55	75	90	115	130	140	160	190	230	270	
<b>A</b>	A1	14	19	24	28	32	32	38	40	55	60
	A2	5	6	8	8	10	10	12	12	16	18
	A3	16	21.5	27	31	35	35	41	43	59	64
	A4	M5 x P0.8	M6 x P1.0	M8 x P1.25	M10 x P1.5	M10 x P1.5	M10 x P1.5	M12 x P1.75	M12 x P1.75	M16 x P2.0	M16 x P2.0
<b>B</b>	B1	2.5	2.5	2.5	2.5	5	5	5	5	5	5
	B2	20	25	35	35	40	40	50	50	70	90
	B3	147	181	218	260	293	315	367	403	483	567
	B4	57	66	78	90	101	100	127	139	183	217
	B5	90	115	140	170	192	215	240	264	300	350
	B6	78	98	118	144	164	182	206	224	260	300
	B7	39	49	59	72	82	91	103	112	130	150
	B8	27	32	42.5	42.5	52.5	51.5	63	63.5	83	105
	B9	25	30	40	40	50	50	60	60	80	100
	B10	84	103	128	148	173	200	227	254	295	328
	B11	6.8	9	11	11	13.5	15	17.5	17.5	17.5	22
	B12	44	54	66	80	95	104	120	140	180	200
	B13	22	27	33	40	47.5	52	60	70	90	100
	B14	M6 x P1.0	M8 x P1.25	M10 x P1.5	M12 x P1.75	M12 x P1.75	M14 x P2.0	M16 x P2.0	M16 x P2.0	M16 x P2.0	M20 x P2.0
<b>C</b>	C1	130	160	188	222	242	261	286	320	390	424
	C2	65	80	94	111	121	130.5	143	160	195	212
	C3	60	80	100	120	138	146	166	196	250	280
	C4	-	-	-	-	14	16	18	20	22	25
	C5	-	-	-	-	51.8	59.3	64.3	74.9	85.4	95.4
	C6	20	25	30	40	48	55	60	70	80	90
	C7	28	34	44	52	60	73	73	83	100	110
	C8	6-M6	8-M6	8-M6	8-M6	8-M8	12-M8	12-M8	12-M8	12-M10	12-M10
	C9	9	14	18	23	27	32	38	42	50	56
Weight ±3% (kg)		5.4	9.9	15.9		29.3		56.0			

# HY-FS series

RATIO : 5.10.15 ( 單段 1-Stage)

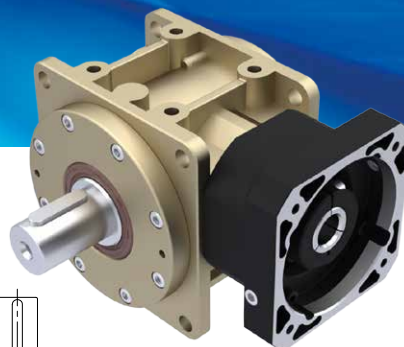

入力法蘭 - 單出力軸心

Input Flange - Single Output Shaft

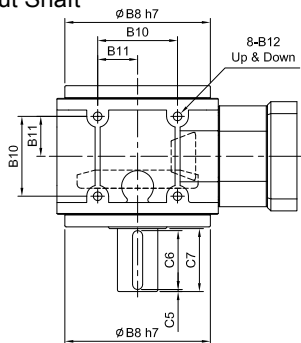

(140#~270#)

$\phi A1$	D	E
$\phi 32$	10	35.3
$\phi 35$	10	38.3
$\phi 38$	10	41.3
$\phi 42$	12	45.3
$\phi 48$	14	51.8
$\phi 55$	16	59.3
$\phi 60$	18	64.4
$\phi 65$	18	69.4

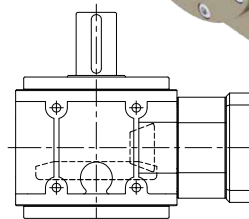

R 軸  
Shaft Direction

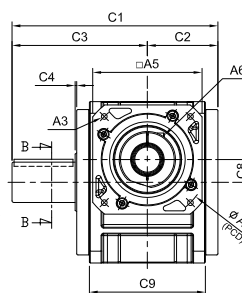
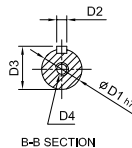
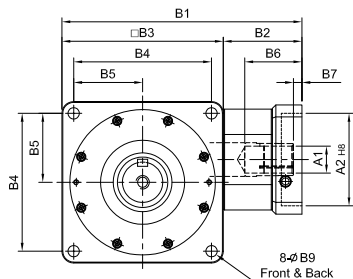

unit: mm

Model Code	55	75	90	115	130	140	160	190	230	270	
A	A1	8 · 11 · 14	14	14 · 19 · 24	19 · 22 · 24	24 · 28 · 32	32 · 35 · 38	32 · 35 · 38	42 · 48 · 55	42 · 48 · 55 · 60	48 · 55 · 60 · 65
	A2	30 · 40 · 50	50 · 60 · 70	50 · 70 · 80 · 95	70 · 80 · 95 · 110	95 · 110 · 130	110 · 130 · 180	110 · 130 · 180	114.3 · 180 · 230 · 250	114.3 · 180 · 230 · 250	114.3 · 180 · 230 · 250
	A3	M3 · M4 · M5	M4 · M5 · M6	M5 · M6	M5 · M6 · M8	M6 · M8 · M10	M8 · M10 · M12	M8 · M10 · M12	M12 · M16	M12 · M16	M12 · M16
	A4	46 · 60 · 63	70 · 75 · 90	70 · 90 · 100 · 115	90 · 100 · 115 · 145	115 · 145 · 165	145 · 165 · 200	145 · 165 · 200	200 · 215 · 265 · 300	200 · 215 · 265 · 300	200 · 215 · 265 · 300
	A5	46 · 55	64 · 70 · 80	80 · 92 · 110	92 · 110 · 130	122 · 130 · 150	146 · 150 · 190	146 · 150 · 190	182 · 200 · 250 · 265	182 · 200 · 250 · 265	222 · 220 · 250 · 265
	A6	M3 x P.05	M5 x P.0.8	M5 x P.0.8	M6 x P.1.0	M8 x P.1.25	M10 x P.1.5	M10 x P.1.5	M10 x P.1.5	M10 x P.1.5	M10 x P.1.5
B	B1	135	172	202 · 221 · 206.5	241	286	333	358	417 · 419	470 · 473	515.5 · 518.5 · 545
	B2	45	57	62 · 81 · 66.5	71	94	118	118	153 · 155	170 · 173	165.5 · 168.5 · 195
	B3	90	115	140	170	192	215	240	264	300	350
	B4	78	98	118	144	164	182	206	224	260	300
	B5	39	49	59	72	82	91	103	112	130	150
	B6	28 · 33	38	49 · 68.5 · 54	58	69.5	81.5	81.5	114.5 · 116.5	112 · 115 · 120 · 123	112.5 · 115.5 · 142
	B7	5	6	9 · 23.5	8	10	10	10	11.5 · 13.5	12 · 15	12.5 · 15.5 · 42
	B8	84	103	128	148	173	200	227	254	295	328
	B9	6.8	9	11	11	13.5	15	17.5	17.5	17.5	22
	B10	44	54	66	80	95	104	120	140	180	200
	B11	22	27	33	40	47.5	52	60	70	90	100
	B12	M6 x P.1.0	M8 x P.1.25	M10 x P.1.5	M12 x P.1.75	M12 x P.1.75	M14 x P.2.0	M16 x P.2.0	M16 x P.2.0	M16 x P.2.0	M16 x P.2.0
C	C1	121	146	180	214	245	275	310	350	415	459
	C2	42	52	64	76	84	91.5	103	118	146	163
	C3	79	94	120	138	161	183.5	206	231	269	296
	C4	2	2	2	2	2	2	2	2	3	3
	C5	5	5	5	5	5	5	5	5	10	10
	C6	25	30	40	50	65	80	90	100	100	110
	C7	35	40	50	60	75	90	100	110	120	130
	C8	9	14	18	23	27	32	38	42	50	56
	C9	60	80	100	120	138	146	166	196	250	280
D	D1	20	24	32	40	48	55	60	70	80	90
	D2	6	8	10	12	14	16	18	20	22	25
	D3	22.5	27	35	43	51.5	59	64	74.5	85	95
	D4	M6 x P.1.0	M8 x P.1.25	M10 x P.1.5	M10 x P.1.5	M12 x P.1.75	M16 x P.2.0	M20 x P.2.5	M20 x P.2.5	M20 x P.2.5	M20 x P.2.5
Weight ±3% (kg)	2.6	4.5	9.0	14.9	22.2	32.3			65.5		138.28

# HY-RS series

RATIO : 25.50.75.100.150 ( 雙段 2-Stage)

搭配行星減速機 - 單出力軸心

Fitted with Planetary Reducer - Single Output Shaft

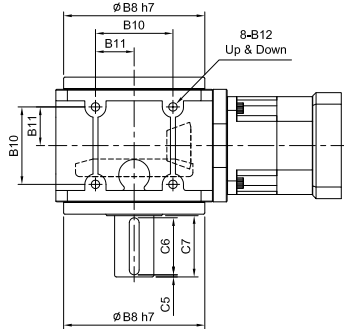
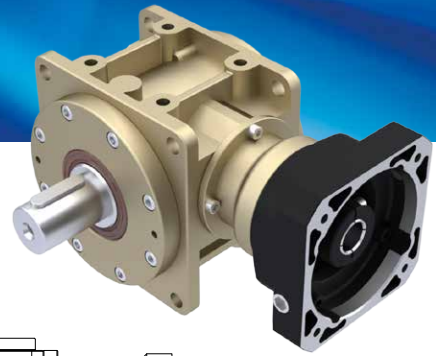

(140#~270#)

ØA1	D	E
Ø28	8	31.3
Ø32	10	35.3
Ø35	10	38.3
Ø38	10	41.3
Ø42	12	45.3
Ø48	14	51.8
Ø55	16	59.3

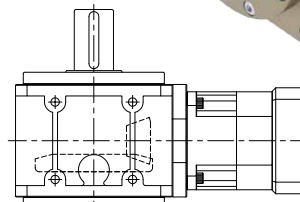

R 軸  
Shaft Direction

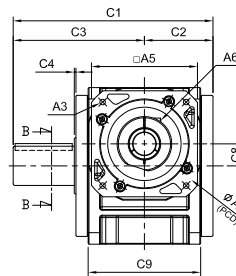
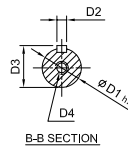
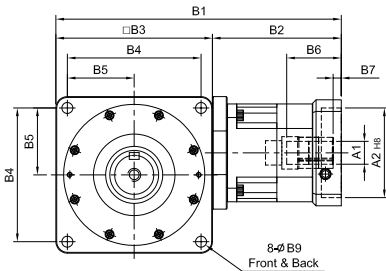

unit: mm

Model Code	55	75	90	115	130	140	160	190	230	270	
A	A1	8 · 9 · 11 · 14	11 · 14 · 16 · 19	(14) · 16 · 19	16 · 19 · 22 · 24	22 · 24 · 28 · 32 · 35	28 · 32 · 35 · 38	28 · 32 · 35 · 38	35 · 38 · 42 · 48 · 55	35 · 38 · 42 · 48 · 55	38 · 42 · 48 · 55
	A2	30 · 40 · 50	50 · 60 · 70	50 · 70 · 80 · 95	70 · 80 · 95 · 110	95 · 110 · 130	110 · 130 · 180	110 · 130 · 180	114.3 · 180 · 230 · 250	114.3 · 180 · 230 · 250	114.3 · 180 · 230 · 250
	A3	M3 · M4 · M5	M4 · M5 · M6	M5 · M6	M5 · M6 · M8	M6 · M8 · M10	M8 · M10 · M12	M8 · M10 · M12	M12 · M16	M12 · M16	M12 · M16
	A4	46 · 60 · 63	70 · 75 · 90	70 · 90 · 100 · 115	90 · 100 · 115 · 145	115 · 145 · 165	145 · 165 · 200	145 · 165 · 200	200 · 215 · 265 · 300	200 · 215 · 265 · 300	200 · 215 · 265 · 300
	A5	46 · 55	64 · 70 · 80	80 · 92 · 110	92 · 110 · 130	122 · 130 · 150	146 · 150 · 190	146 · 150 · 190	182 · 200 · 250 · 265	182 · 200 · 250 · 265	222 · 220 · 250 · 265
	A6	M3 x P.05	M5 x P.0.8	M5 x P.0.8	M6 x P1.0	M8 x P1.25	M10 x P1.5	M10 x P1.5	M10 x P1.5	M10 x P1.5	M10 x P1.5
B	B1	157	201 · 209	(224.5) · 237	287	340 · 360	405	430	508 · 510	572	642.5
	B2	67	86 · 94	(84.5) · 97	117	148 · 168	190	190	244 · 246	272	292.5
	B3	90	115	140	170	192	215	240	264	300	350
	B4	78	98	118	144	164	182	206	224	260	300
	B5	39	49	59	72	82	91	103	112	130	150
	B6	26	33.5 · 41.5	(33.5) · 45.5	59	67 · 83	84.5	84.5	114.5 · 116.5	112 · 115	112.5 · 115.5 · 142
	B7	5	6	(6) · 10	9	10 · 11	10	10	11.5 · 13.5	12 · 15	12.5 · 15.5 · 42
	B8	84	103	128	148	173	200	227	254	295	328
	B9	6.8	9	11	11	13.5	15	17.5	17.5	17.5	22
	B10	44	54	66	80	95	104	120	140	180	200
	B11	22	27	33	40	47.5	52	60	70	90	100
	B12	M6 x P1.0	M8 x P1.25	M10 x P1.5	M12 x P1.75	M12 x P1.75	M14 x P2.0	M16 x P2.0	M16 x P2.0	M16 x P2.0	M16 x P2.0
C	C1	121	146	180	214	245	275	310	350	415	459
	C2	42	52	64	76	84	91.5	103	118	146	163
	C3	79	94	120	138	161	183.5	206	231	269	296
	C4	2	2	2	2	2	2	2	2	3	3
	C5	5	5	5	5	5	5	5	5	10	10
	C6	25	30	40	50	65	80	90	100	100	110
	C7	35	40	50	60	75	90	100	110	120	130
	C8	9	14	18	23	27	32	38	42	50	56
	C9	60	80	100	120	138	146	166	196	250	280
D	D1	20	24	32	40	48	55	60	70	80	90
	D2	6	8	10	12	14	16	18	20	22	25
	D3	22.5	27	35	43	51.5	59	64	74.5	85	95
	D4	M6 x P1.0	M8 x P1.25	M10 x P1.5	M10 x P1.5	M12 x P1.75	M16 x P2.0	M20 x P2.5	M20 x P2.5	M20 x P2.5	M20 x P2.5
Weight ±3% (kg)	2.9	5.5	9.5	16.2	27.7	41.0	54.2	82.2			

# HY-DS series

RATIO : 5.10.15 (單段 1-Stage)

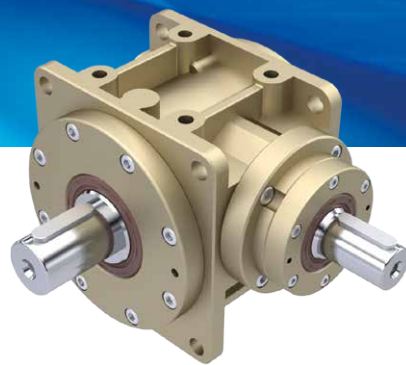

單入力軸心 - 單出力軸心

Single Input Shaft - Single Output Shaft

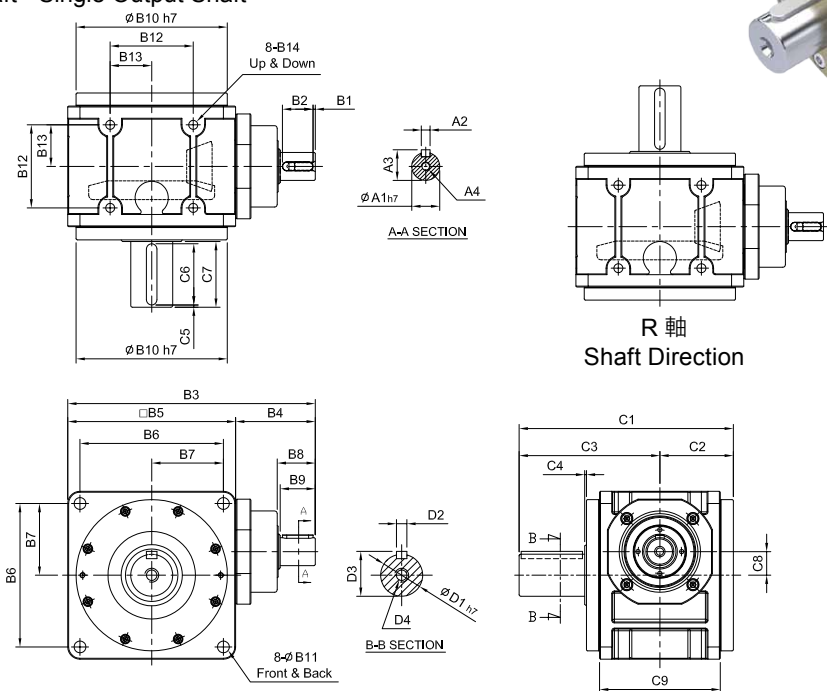

unit: mm

Model Code	55	75	90	115	130	140	160	190	230	270	
<b>A</b>	A1	14	19	24	28	32	32	38	40	55	60
	A2	5	6	8	8	10	10	12	12	16	18
	A3	16	21.5	27	31	35	35	41	43	59	64
	A4	M5 x P0.8	M6 x P1.0	M8 x P1.25	M10 x P1.5	M10 x P1.5	M10 x P1.5	M12 x P1.75	M12 x P1.75	M16 x P2.0	M16 x P2.0
<b>B</b>	B1	2.5	2.5	2.5	2.5	5	5	5	5	5	5
	B2	20	25	35	35	40	40	50	50	70	90
	B3	147	180.5	218	260	293	315	367	402.5	483	567
	B4	57	65.5	78	90	101	100	127	138.5	183	217
	B5	90	115	140	170	192	215	240	264	300	350
	B6	78	98	118	144	164	182	206	224	260	300
	B7	39	49	59	72	82	91	103	112	130	150
	B8	27	32	42.5	42.5	52.5	51.5	63	63.5	83	105
	B9	25	30	40	40	50	50	60	60	80	100
	B10	84	103	128	148	173	200	227	254	295	328
	B11	6.8	9	11	11	13.5	15	17.5	17.5	17.5	22
	B12	44	54	66	80	95	104	120	140	180	200
	B13	22	27	33	40	47.5	52	60	70	90	100
	B14	M6 x P1.0	M8 x P1.25	M10 x P1.5	M12 x P1.75	M12 x P1.75	M14 x P2.0	M16 x P2.0	M16 x P2.0	M16 x P2.0	M20 x P2.0
<b>C</b>	C1	121	146	180	214	245	275	310	350	415	459
	C2	42	52	64	76	84	91.5	103	118	146	163
	C3	79	94	120	138	161	183.5	206	231	269	296
	C4	2	2	2	2	2	2	2	2	3	3
	C5	5	5	5	5	5	5	5	5	10	10
	C6	25	30	40	50	65	80	90	100	100	110
	C7	35	40	50	60	75	90	100	110	120	130
	C8	9	14	18	23	27	32	38	42	50	56
	C9	60	80	100	120	138	146	166	196	250	280
<b>D</b>	D1	20	24	32	40	48	55	60	70	80	90
	D2	6	8	10	12	14	16	18	20	22	25
	D3	22.5	27	35	43	51.5	59	64	74.5	85	95
	D4	M6 x P1.0	M8 x P1.25	M10 x P1.5	M10 x P1.5	M12 x P1.75	M16 x P2.0	M20 x P2.5	M20 x P2.5	M20 x P2.5	M20 x P2.5
Weight $\pm 3\%$ (kg)	3.1	5.1		15.9		33.2		64.8			



# HY-FV series

RATIO : 5.10.15 ( 單段 1-Stage)

入力法蘭 - 雙出力軸心

Input Flange - Double Output Shaft

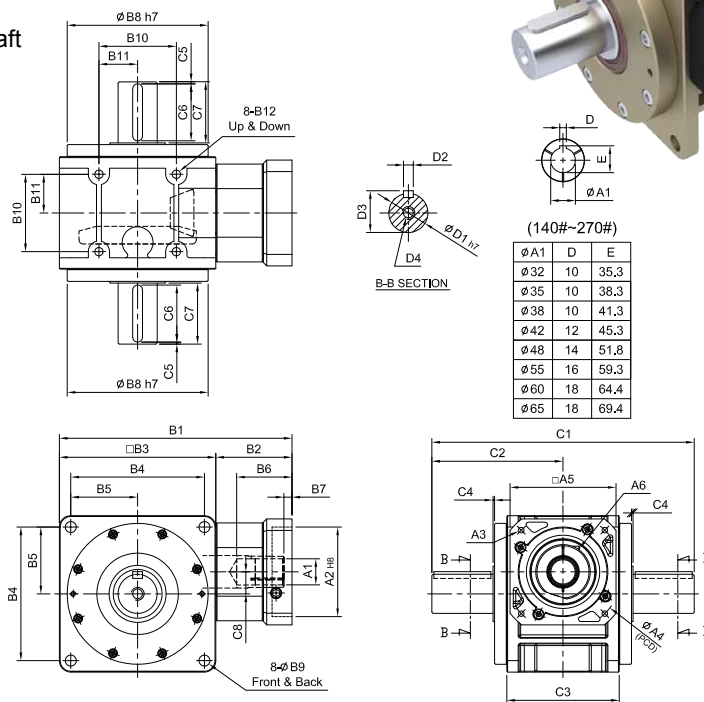
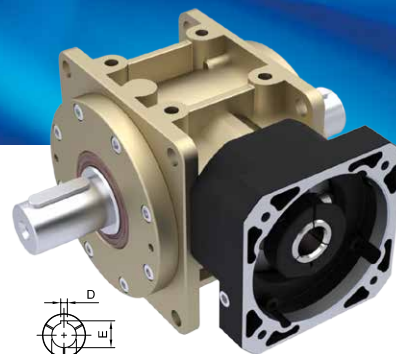

unit: mm

Model Code	55	75	90	115	130	140	160	190	230	270	
A	A1	8 · 11 · 14	14	14 · 19 · 24	19 · 22 · 24	24 · 28 · 32	32 · 35 · 38	32 · 35 · 38	42 · 48 · 55	42 · 48 · 55 · 60	48 · 55 · 60 · 65
	A2	30 · 40 · 50	50 · 60 · 70	50 · 70 · 80 · 95	70 · 80 · 95 · 110	95 · 110 · 130	110 · 130 · 180	110 · 130 · 180	114.3 · 180 · 230 · 250	114.3 · 180 · 230 · 250	114.3 · 180 · 230 · 250
	A3	M3 · M4 · M5	M4 · M5 · M6	M5 · M6	M5 · M6 · M8	M6 · M8 · M10	M8 · M10 · M12	M8 · M10 · M12	M12 · M16	M12 · M16	M12 · M16
	A4	46 · 60 · 63	70 · 75 · 90	70 · 90 · 100 · 115	90 · 100 · 115 · 145	115 · 145 · 165	145 · 165 · 200	145 · 165 · 200	200 · 215 · 265 · 300	200 · 215 · 265 · 300	200 · 215 · 265 · 300
	A5	46 · 55	64 · 70 · 80	80 · 92 · 110	92 · 110 · 130	122 · 130 · 150	146 · 150 · 190	146 · 150 · 190	182 · 200 · 250 · 265	182 · 200 · 250 · 265	222 · 220 · 250 · 265
	A6	M3 x P.05	M5 x P.0.8	M5 x P.0.8	M6 x P1.0	M8 x P1.25	M10 x P1.5	M10 x P1.5	M10 x P1.5	M10 x P1.5	M10 x P1.5
B	B1	135	172	202 · 221 · 206.5	241	286	333	358	417 · 419	470,473	515.5 · 518.5 · 545
	B2	45	57	62 · 81 · 66.5	71	94	118	118	153 · 155	170 · 173	165.5 · 168.5 · 195
	B3	90	115	140	170	192	215	240	264	300	350
	B4	78	98	118	144	164	182	206	224	260	300
	B5	39	49	59	72	82	91	103	112	130	150
	B6	28 · 33	38	49 · 68.5 · 54	58	69.5	81.5	81.5	114.5 · 116.5	112 · 115 · 120 · 123	112.5 · 115.5 · 142
	B7	5	6	9 · 23.5	8	10	10	10	11.5 · 13.5	12 · 15	12.5 · 15.5 · 42
	B8	84	103	128	148	173	200	227	254	295	328
	B9	6.8	9	11	11	13.5	15	17.5	17.5	17.5	22
	B10	44	54	66	80	95	104	120	140	180	200
	B11	22	27	33	40	47.5	52	60	70	90	100
	B12	M6 x P1.0	M8 x P1.25	M10 x P1.5	M12 x P1.75	M12 x P1.75	M14 x P2.0	M16 x P2.0	M16 x P2.0	M16 x P2.0	M16 x P2.0
C	C1	158	188	232	276	322	367	412	462	538	592
	C2	79	94	116	138	161	183.5	206	231	269	296
	C3	60	80	100	120	138	146	166	196	250	280
	C4	2	2	2	2	2	2	2	2	3	3
	C5	5	5	5	5	5	5	5	5	10	10
	C6	25	30	40	50	65	80	90	100	100	110
	C7	35	40	50	60	75	90	100	110	120	130
	C8	9	14	18	23	27	32	38	42	50	56
D	D1	20	24	32	40	48	55	60	70	80	90
	D2	6	8	10	12	14	16	18	20	22	25
	D3	22.5	27	35	43	51.5	59	64	74.5	85	95
	D4	M6 x P1.0	M8 x P1.25	M10 x P1.5	M10 x P1.5	M12 x P1.75	M16 x P2.0	M20 x P2.5	M20 x P2.5	M20 x P2.5	M20 x P2.5
Weight $\pm 3\%$ (kg)						35.1	47.3	70.7			

# HY-RV series

RATIO : 25.50.75.100.150 ( 雙段 2-Stage)

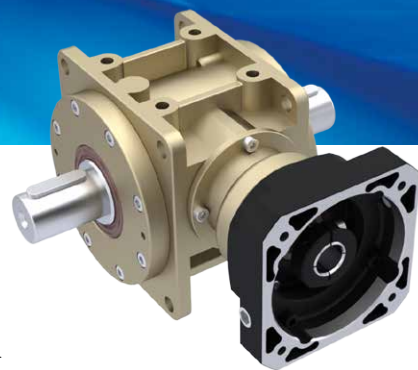

搭配行星減速機 - 雙出力軸心

Fitted with Planetary Reducer - Double Output Shaft

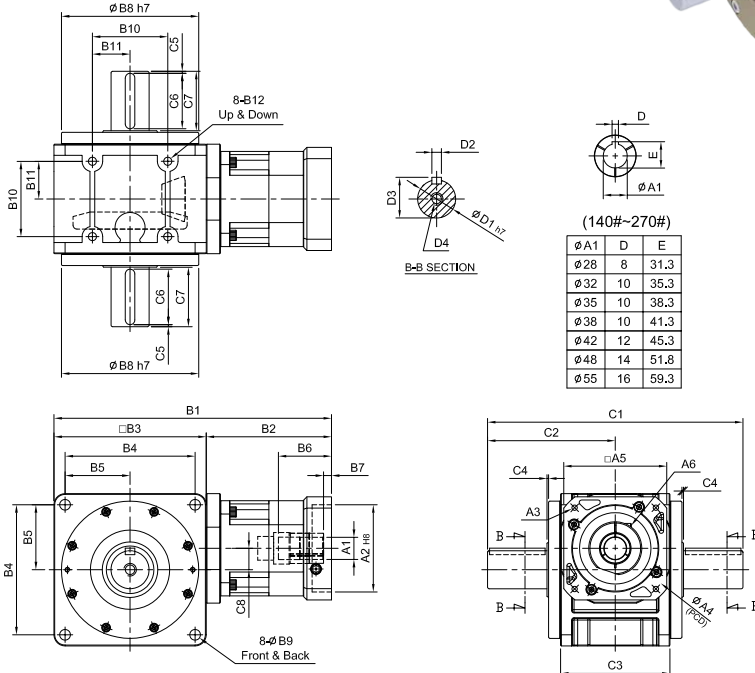

unit: mm

Model Code	55	75	90	115	130	140	160	190	230	270	
<b>A</b>	A1	8·9·11·14	11·14·16·19	(14)·16·19	16·19·22·24	22·24·28·32·35	28·32·35·38	28·32·35·38	35·38·42·48·55	35·38·42·48·55	38·42·48·55
	A2	30·40·50	50·60·70	50·70·80·95	70·80·95·110	95·110·130	110·130·180	110·130·180	114.3·180·230·250	114.3·180·230·250	114.3·180·230·250
	A3	M3·M4·M5	M4·M5·M6	M5·M6	M5·M6·M8	M6·M8·M10	M8·M10·M12	M8·M10·M12	M12·M16	M12·M16	M12·M16
	A4	46·60·63	70·75·90	70·90·100·115	90·100·115·145	115·145·165	145·165·200	145·165·200	200·215·265·300	200·215·265·300	200·215·265·300
	A5	46·55	64·70·80	80·92·110	92·110·130	122·130·150	146·150·190	146·150·190	182·200·250·265	182·200·250·265	222·220·250·265
	A6	M3 x P.05	M5 x P0.8	M5 x P0.8	M6 x P1.0	M8 x P1.25	M10 x P1.5	M10 x P1.5	M10 x P1.5	M10 x P1.5	M10 x P1.5
<b>B</b>	B1	157	201·209	(224.5)·237	287	340·360	405	430	508·510	572	642.5
	B2	67	86·94	(84.5)·97	117	148·168	190	190	244·246	272	292.5
	B3	90	115	140	170	192	215	240	264	300	350
	B4	78	98	118	144	164	182	206	224	260	300
	B5	39	49	59	72	82	91	103	112	130	150
	B6	26	33.5·41.5	(33.5)·45.5	59	67·83	84.5	84.5	114.5·116.5	112,115	112.5·115.5·142
	B7	5	6	(6)·10	9	10·11	10	10	11.5·13.5	12·15	12.5·15.5·42
	B8	84	103	128	148	173	200	227	254	295	328
	B9	6.8	9	11	11	13.5	15	17.5	17.5	17.5	22
	B10	44	54	66	80	95	104	120	140	180	200
	B11	22	27	33	40	47.5	52	60	70	90	100
	B12	M6 x P1.0	M8 x P1.25	M10 x P1.5	M12 x P1.75	M12 x P1.75	M14 x P2.0	M16 x P2.0	M16 x P2.0	M16 x P2.0	M16 x P2.0
<b>C</b>	C1	158	188	232	276	322	367	412	462	538	592
	C2	79	94	116	138	161	183.5	206	231	269	296
	C3	60	80	100	120	138	146	166	196	250	280
	C4	2	2	2	2	2	2	2	2	3	3
	C5	5	5	5	5	5	5	5	5	10	10
	C6	25	30	40	50	65	80	90	100	100	110
	C7	35	40	50	60	75	90	100	110	120	130
	C8	9	14	18	23	27	32	38	42	50	56
<b>D</b>	D1	20	24	32	40	48	55	60	70	80	90
	D2	6	8	10	12	14	16	18	20	22	25
	D3	22.5	27	35	43	51.5	59	64	74.5	85	95
	D4	M6 x P1.0	M8 x P1.25	M10 x P1.5	M10 x P1.5	M12 x P1.75	M16 x P2.0	M20 x P2.5	M20 x P2.5	M20 x P2.5	M20 x P2.5
Weight ±3% (kg)	3.0	5.6	9.8	18.0	28.5	42.6	55.2	84.0			

# HY-DV series

RATIO : 5.10.15 ( 單段 1-Stage)

單入力軸心 - 雙出力軸心

Single Input Shaft - Double Output Shaft

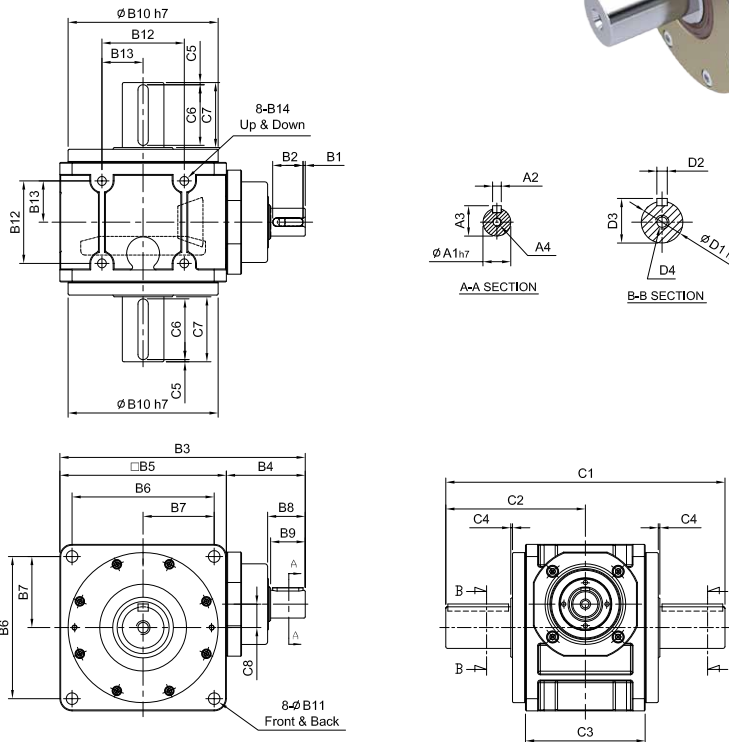
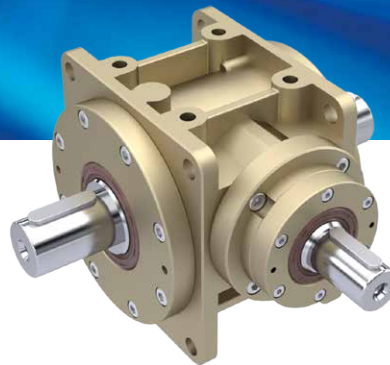

unit: mm

Model Code	55	75	90	115	130	140	160	190	230	270	
	<b>A</b>	A1	14	19	24	28	32	32	38	40	55
	A2	5	6	8	8	10	10	12	12	16	18
	A3	16	21.5	27	31	35	35	41	43	59	64
	A4	M5 x P0.8	M6 x P1.0	M8 x P1.25	M10 x P1.5	M10 x P1.5	M10 x P1.5	M12 x P1.75	M12 x P1.75	M16 x P2.0	M16 x P2.0
<b>B</b>	B1	2.5	2.5	2.5	2.5	5	5	5	5	5	5
	B2	20	25	35	35	40	40	50	50	70	90
	B3	147	181	218	260	293	315	367	403	483	567
	B4	57	66	78	90	101	100	127	139	183	217
	B5	90	115	140	170	192	215	240	264	300	350
	B6	78	98	118	144	164	182	206	224	260	300
	B7	39	49	59	72	82	91	103	112	130	150
	B8	27	32	42.5	42.5	52.5	51.5	63	63.5	83	105
	B9	25	30	40	40	50	50	60	60	80	100
	B10	84	103	128	148	173	200	227	254	295	328
	B11	6.8	9	11	11	13.5	15	17.5	17.5	17.5	22
	B12	44	54	66	80	95	104	120	140	180	200
	B13	22	27	33	40	47.5	52	60	70	90	100
		B14	M6 x P1.0	M8 x P1.25	M10 x P1.5	M12 x P1.75	M12 x P1.75	M14 x P2.0	M16 x P2.0	M16 x P2.0	M16 x P2.0
<b>C</b>	C1	158	188	232	276	322	367	412	462	538	592
	C2	79	94	116	138	161	183.5	206	231	269	296
	C3	60	80	100	120	138	146	166	196	250	280
	C4	2	2	2	2	2	2	2	2	3	3
	C5	5	5	5	5	5	5	5	5	10	10
	C6	25	30	40	50	65	80	90	100	100	110
	C7	35	40	50	60	75	90	100	110	120	130
	C8	9	14	18	23	27	32	38	42	50	56
<b>D</b>	D1	20	24	32	40	48	55	60	70	80	90
	D2	6	8	10	12	14	16	18	20	22	25
	D3	22.5	27	35	43	51.5	59	64	74.5	85	95
	D4	M6 x P1.0	M8 x P1.25	M10 x P1.5	M10 x P1.5	M12 x P1.75	M16 x P2.0	M20 x P2.5	M20 x P2.5	M20 x P2.5	M20 x P2.5
Weight ±3% (kg)	3.2	5.2	9.7	16.4		34.4		67.9			

# HY-FP series

RATIO : 5.10.15 (單段 1-Stage)

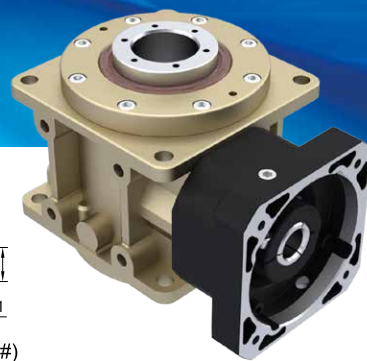

入力法蘭 - 螺桿式

Input Flange - Ball Screw

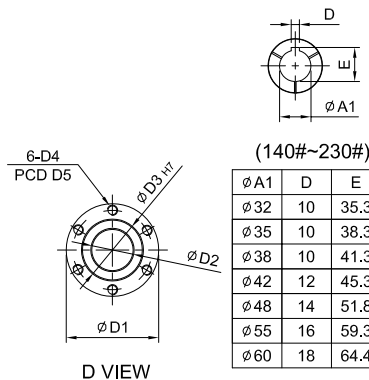
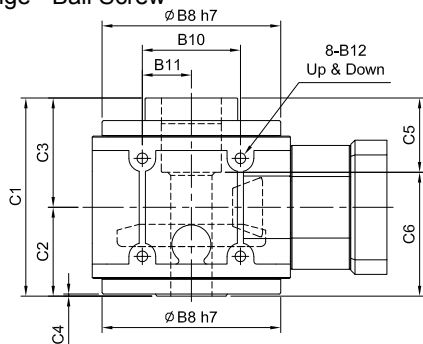

(140#~230#)

φA1	D	E
φ32	10	35.3
φ35	10	38.3
φ38	10	41.3
φ42	12	45.3
φ48	14	51.8
φ55	16	59.3
φ60	18	64.4

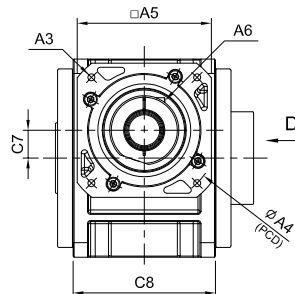
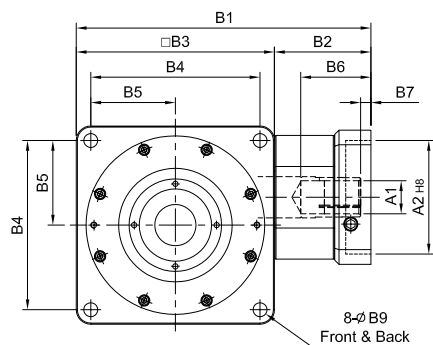

unit: mm

Model Code	75	90	115	130	140	160	190	230	
A	A1	14	14 · 19 · 24	19 · 22 · 24	24 · 28 · 32	32 · 35 · 38	32 · 35 · 38	42 · 48 · 55	42 · 48 · 55 · 60
	A2	50 · 60 · 70	50 · 70 · 80 · 95	70 · 80 · 95 · 110	95 · 110 · 130	110 · 130 · 180	110 · 130 · 180	114.3 · 180 · 230 · 250	114.3 · 180 · 230 · 250
	A3	M4 · M5 · M6	M5 · M6	M5 · M6 · M8	M6 · M8 · M10	M8 · M10 · M12	M8 · M10 · M12	M12 · M16	M12 · M16
	A4	70 · 75 · 90	70 · 90 · 100 · 115	90 · 100 · 115 · 145	115 · 145 · 165	145 · 165 · 200	145 · 165 · 200	200 · 215 · 265 · 300	200 · 215 · 265 · 300
	A5	64 · 70 · 80	80 · 92 · 110	92 · 110 · 130	122 · 130 · 150	146 · 150 · 190	146 · 150 · 190	182 · 200 · 250 · 265	182 · 200 · 250 · 265
	A6	M5 x P0.8	M5 x P0.8	M6 x P1.0	M8 x P1.25	M10 x P1.5	M10 x P1.5	M10 x P1.5	M10 x P1.5
B	B1	172	202 · 221 · 206.5	241	286	333	358	417 · 419	470 · 473
	B2	57	62 · 81 · 66.5	71	94	118	118	153 · 155	170 · 173
	B3	115	140	170	192	215	240	264	300
	B4	98	118	144	164	182	206	224	260
	B5	49	59	72	82	91	103	112	130
	B6	38	49 · 68.5 · 54	58	69.5	81.5	81.5	114.5 · 116.5	112 · 115 · 120 · 123
	B7	6	9 · 23.5	8	10	10	10	11.5 · 13.5	12 · 15
	B8	103	128	148	173	200	227	254	295
	B9	9	11	11	13.5	15	17.5	17.5	17.5
	B10	54	66	80	95	104	120	140	180
	B11	27	33	40	47.5	52	60	70	90
	B12	M8 x P1.25	M10 x P1.5	M12 x P1.75	M12 x P1.75	M14 x P2.0	M16 x P2.0	M16 x P2.0	M16 x P2.0
C	C1	125	140	177	193	205	230	260	313
	C2	58	66	78.5	87	94	107	123	149
	C3	67	74	98.5	106	111	123	137	164
	C4	3.25	2	2.5	2	2.5	2.5	3	3
	C5	50	58	72	72	82	92	117	117
	C6	75	82	105	121	123	138	143	196
	C7	14	18	23	27	32	38	42	50
	C8	80	100	120	138	146	166	196	250
D	D1	54.7	64.7	89.7	89.7	99.7	117.7	129.7	139.5
	D2	22	30	38	40	44	54	65	65
	D3	34	40	58	58	64	75	90	90
	D4	M5 x P0.8	M5 x P0.8	M10 x P1.5	M10 x P1.5	M10 x P1.5	M12 x P1.75	M12 x P1.75	M12 x P1.75
	D5	45	51	77	77	84	97	112	112
Weight ±3% (kg)	4.5	8.2	13.3	20.0	29.1		56.3	56.3	

# HY-RP series

RATIO : 25.50.75.100.150 (雙段 2-Stage)

搭配行星減速機 - 螺桿式

Fitted with Planetary Reducer - Ball Screw

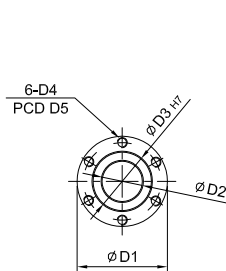
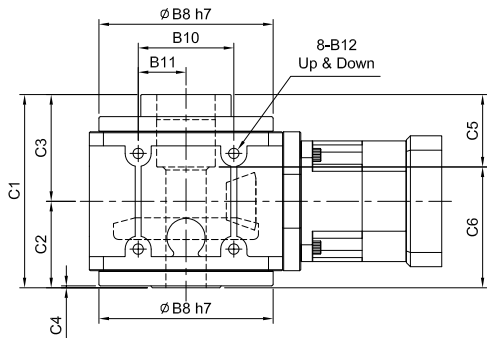
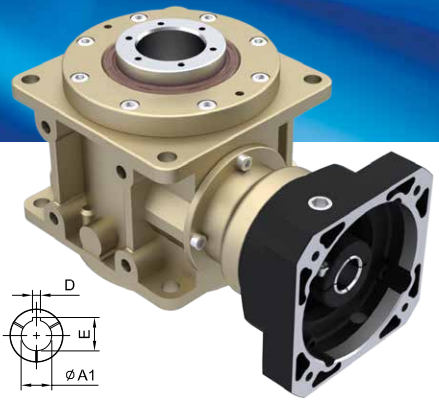

(140#~230#)

φ A1	D	E
φ28	8	31.3
φ32	10	35.3
φ35	10	38.3
φ38	10	41.3
φ42	12	45.3
φ48	14	51.8
φ55	16	59.3

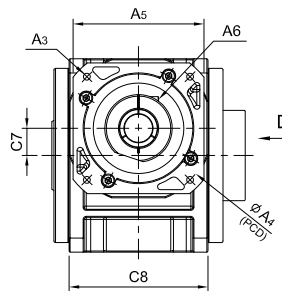
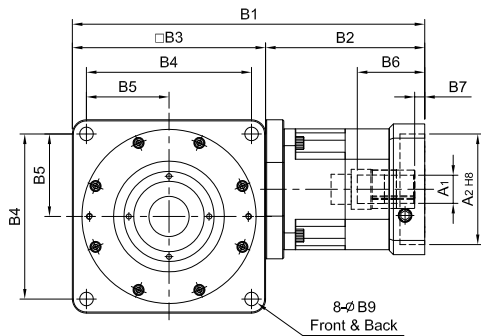

unit: mm

Model Code	75	90	115	130	140	160	190	230
	A1	11 · 14 · 16 · 19	(14) · 16 · 19	16 · 19 · 22 · 24	22 · 24 · 28 · 32 · 35	28 · 32 · 35 · 38	28 · 32 · 35 · 38	35 · 38 · 42 · 48 · 55
A2	50 · 60 · 70	50 · 70 · 80 · 95	70 · 80 · 95 · 110	95 · 110 · 130	110 · 130 · 180	110 · 130 · 180	114.3 · 180 · 230 · 250	114.3 · 180 · 230 · 250
A3	M4 · M5 · M6	M5 · M6	M5 · M6 · M8	M6 · M8 · M10	M8 · M10 · M12	M8 · M10 · M12	M12 · M16	M12 · M16
A4	70 · 75 · 90	70 · 90 · 100 · 115	90 · 100 · 115 · 145	115 · 145 · 165	145 · 165 · 200	145 · 165 · 200	200 · 215 · 265 · 300	200 · 215 · 265 · 300
A5	64 · 70 · 80	80 · 92 · 110	92 · 110 · 130	122 · 130 · 150	146 · 150 · 190	146 · 150 · 190	182 · 200 · 250 · 265	182 · 200 · 250 · 265
A6	M5 x P0.8	M5 x P0.8	M6 x P1.0	M8 x P1.25	M10 x P1.5	M10 x P1.5	M10 x P1.5	M10 x P1.5
B1	201 · 209	(224.5) · 237	287	340 · 360	405	430	508 · 510	571.5
B2	86 · 94	(84.5) · 97	117	148 · 168	190	190	244 · 246	271.5
B3	115	140	170	192	215	240	264	300
B4	98	118	144	164	182	206	224	260
B5	49	59	72	82	91	103	112	130
B6	33.5 · 41.5	(33.5) · 45.5	59	67 · 83	84.5	84.5	114.5 · 116.5	114.5
B7	6	(6) · 10	9	10 · 11	10	10	11.5 · 13.5	11.5
B8	103	128	148	173	200	227	254	295
B9	9	11	11	13.5	15	17.5	17.5	17.5
B10	54	66	80	95	104	120	140	180
B11	27	33	40	47.5	52	60	70	90
B12	M8 x P1.25	M10 x P1.5	M12 x P1.75	M12 x P1.75	M14 x P2.0	M16 x P2.0	M16 x P2.0	M16 x P2.0
C1	125	140	177	193	205	230	260	313
C2	58	66	78.5	87	94	107	123	149
C3	67	74	98.5	106	111	123	137	164
C4	3.25	2	2.5	2	2.5	2.5	3	3
C5	50	58	72	72	82	92	117	117
C6	75	82	105	121	123	138	143	196
C7	14	18	23	27	32	38	42	50
C8	80	100	120	138	146	166	196	250
D1	54.7	64.7	89.7	89.7	99.7	117.7	129.7	139.5
D2	22	30	38	40	44	54	65	65
D3	34	40	58	58	64	75	90	90
D4	M5 x P0.8	M5 x P0.8	M10 x P1.5	M10 x P1.5	M10 x P1.5	M12 x P1.75	M12 x P1.75	M12 x P1.75
D5	45	51	77	77	84	97	112	112
Weight ±3% (kg)	5.4	8.9	15.4		38.0			



# HY-DP series

RATIO : 5.10.15 (單段 1-Stage)

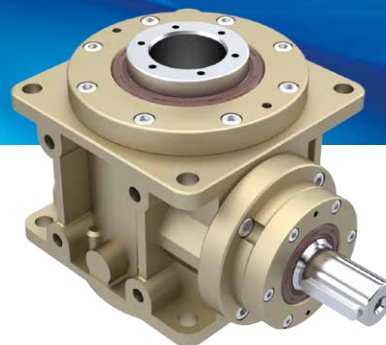

單入力軸心 - 螺桿式

Single Input Shaft - Ball Screw

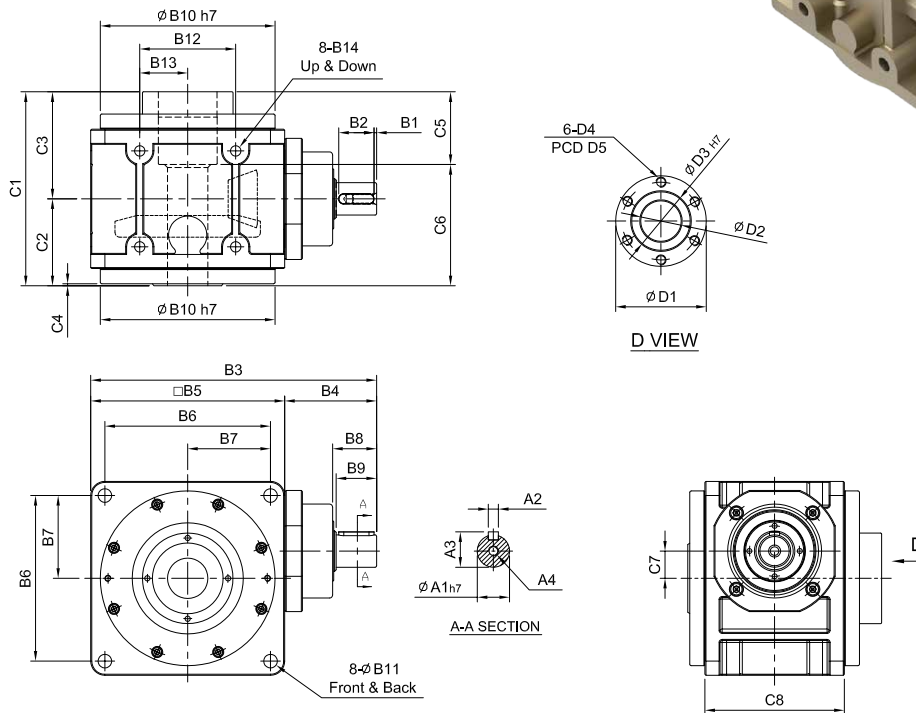

unit: mm

Model Code	75	90	115	130	140	160	190	230	
<b>A</b>	A1	19	24	28	32	32	38	55	
	A2	6	8	8	10	10	12	16	
	A3	21.5	27	31	35	35	41	59	
	A4	M6 x P1.0	M8 x P1.25	M10 x P1.5	M10 x P1.5	M10 x P1.5	M12 x P1.75	M12 x P1.75	M16 x P2.0
<b>B</b>	B1	2.5	2.5	2.5	5	5	5	5	
	B2	25	35	35	40	40	50	70	
	B3	181	218	260	293	315	367	483	
	B4	66	78	90	101	100	127	183	
	B5	115	140	170	192	215	240	300	
	B6	98	118	144	164	182	206	260	
	B7	49	59	72	82	91	103	130	
	B8	32	42.5	42.5	52.5	51.5	63	83	
	B9	30	40	40	50	50	60	80	
	B10	103	128	148	173	200	227	295	
	B11	9	11	11	13.5	15	17.5	17.5	
	B12	54	66	80	95	104	120	180	
	B13	27	33	40	47.5	52	60	90	
	B14	M8 x P1.25	M10 x P1.5	M12 x P1.75	M12 x P1.75	M14 x P2.0	M16 x P2.0	M16 x P2.0	M16 x P2.0
<b>C</b>	C1	125	140	177	193	205	230	313	
	C2	58	66	78.5	87	94	107	149	
	C3	67	74	98.5	106	111	123	164	
	C4	3.25	2	2.5	2	2.5	2.5	3	
	C5	50	58	72	72	82	92	117	
	C6	75	82	105	121	123	138	196	
	C7	14	18	23	27	32	38	50	
	C8	80	100	120	138	146	166	250	
<b>D</b>	D1	54.7	64.7	89.7	89.7	99.7	117.7	139.5	
	D2	22	30	38	40	44	54	65	
	D3	34	40	58	58	64	75	90	
	D4	M5 x P0.8	M5 x P0.8	M10 x P1.5	M10 x P1.5	M10 x P1.5	M12 x P1.75	M12 x P1.75	M12 x P1.75
	D5	45	51	77	77	84	97	112	
Weight $\pm 3\%$ (kg)			8.6						

# Reference Information of Ball Screw

## 滾珠螺桿參考資料

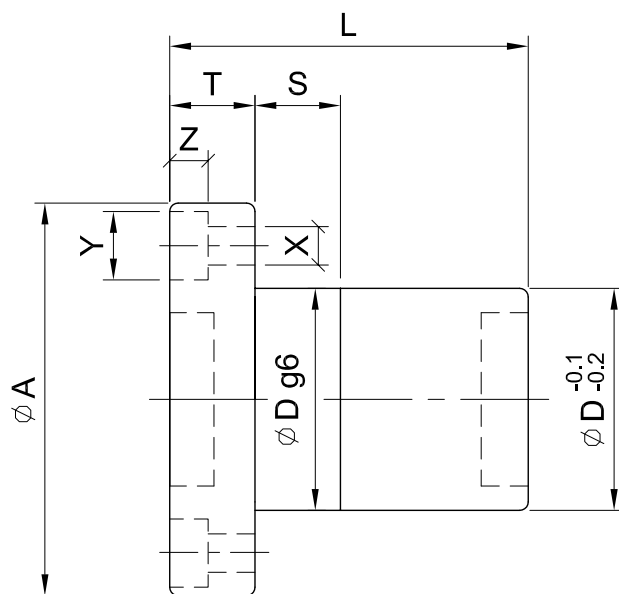
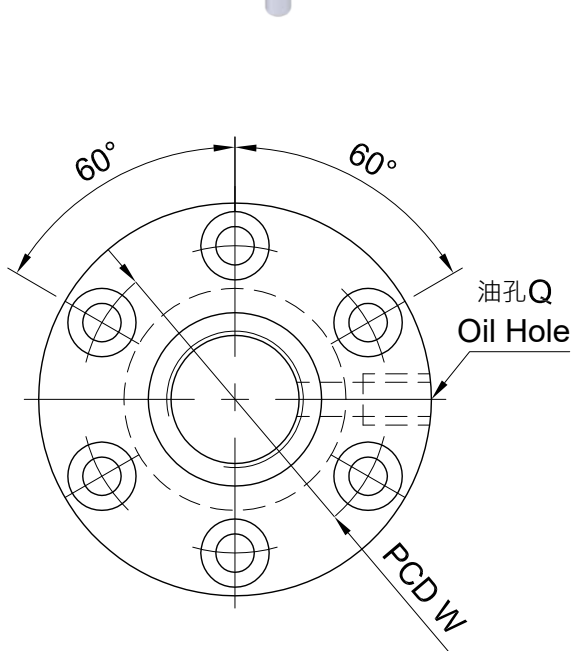

配合 減速機 型號 Model of Reducer	螺桿尺寸 Screw Size		基本額定負荷 Basic Rate Load (kgf)		螺帽 Nut		法蘭 Flange			配合 FIT	螺絲孔 Screw Bolt			油孔 Oil Hole	螺桿 長度 Length
	外徑 O.D.	導程 Lead	動負荷 Dynamic	靜負荷 Static	Dg6	L	A	T	W	S	X	Y	Z	Q	
55	-	-	-	-	-	-	-	-	-	-	-	-	-	-	-
75	20	6	1,380	2,730	34	61	57	12	45	12	5.5	9.5	5.5	M6 x P1	≤ 1500
90	25	8	1,630	3,650	40	69	63.5	12	51	15	5.5	9.5	5.5	M8 x P1	≤ 1500
115	36	10	3,600	8,280	58	89	98	18	77	20	11	17.5	11	M8 x P1	≤ 1500
130	36	10	3,600	8,280	58	89	98	18	77	20	11	17.5	11	M8 x P1	≤ 1500
140	40	10	4,670	11,830	64	99	106	18	84	20	11	17.5	11	M8 x P1	≤ 1500
160	50	12	5,770	14,870	75	111	121	22	97	20	14	20	13	1/8"PT	≤ 1500
190	63	12	9,320	29,150	90	136	136	22	112	20	14	20	13	1/8"PT	≤ 1500
230	63	12	9,320	29,150	90	136	136	22	112	20	14	20	13	1/8"PT	≤ 1500

# Flange (B)

## 旋盤 (B)

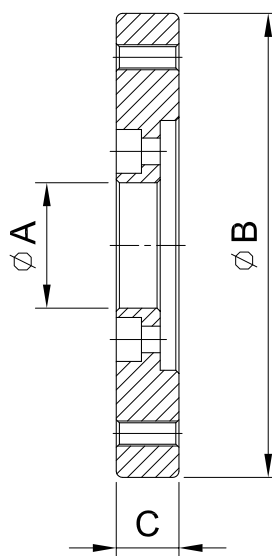
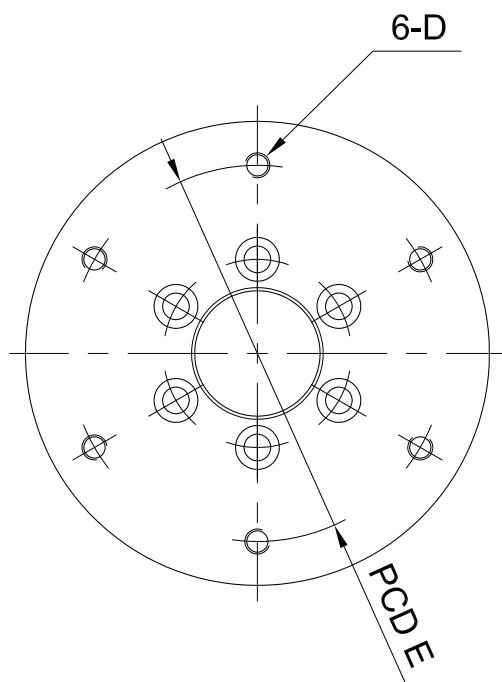

Model	55	75	90	115	130	140	160	190
Code								
A	-	25	30	40	45	50	55	60
B	-	102	128	148	168	198	228	248
C	-	15	16	20	23	24	23	27
D	-	M6 x P1.0	M8 x P1.25	M8 x P1.25	M10 x P1.5	M10 x P1.5	M10 x P1.5	M12 x P1.25
E	-	80	100	120	140	160	180	200

HY

# High Precision Hypoid Gear Reducer and Motor Mounting Instructions 伺服用精密戟齒輪減速機與馬達安裝指南

HY

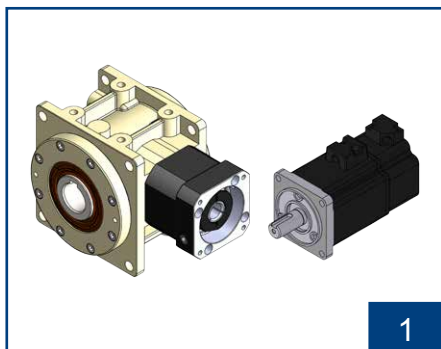

核對馬達型號與減速機規格是否正確。並將配合面擦拭乾淨。  
Confirm the motor, and gearbox size. Clean up the mounting surface.

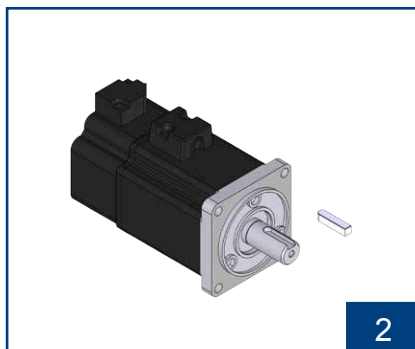

確認減速機與馬達是否有鍵配合。  
Confirm whether the reducer and motor are keyed together.

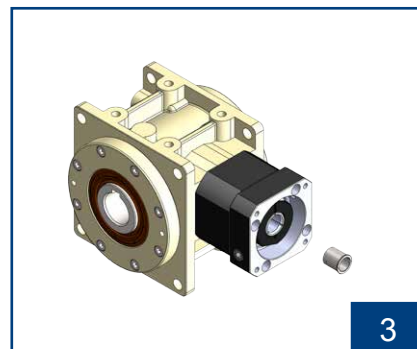

檢查馬達出力軸尺寸，如需軸套，請先裝進減速機入力孔內。  
Check motor shaft size and insert bushing into input bore of the gear box if necessary.

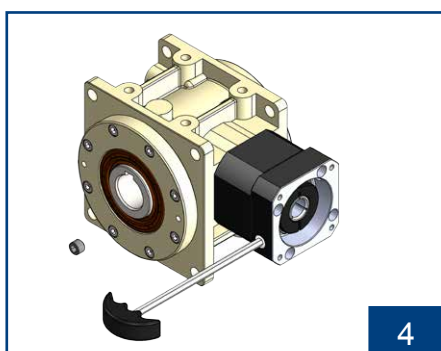

取出塞頭，使用六角扳手將迫緊環螺絲鬆開。並將扳手與螺絲對準孔位。  
Remove the plug on the adapter plate. Rotate the set collar till the bolt is line up.

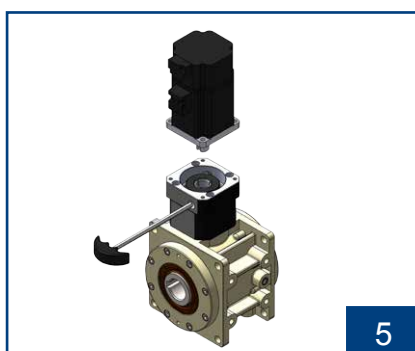

將馬達垂直裝入減速機。  
Put the motor into the gearbox vertically.

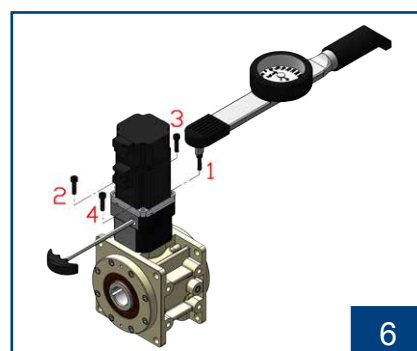

依序 1~4 使用扭力扳手鎖上內六角螺絲。  
Tighten the mounting bolt in 1~4 order with torque wrench.

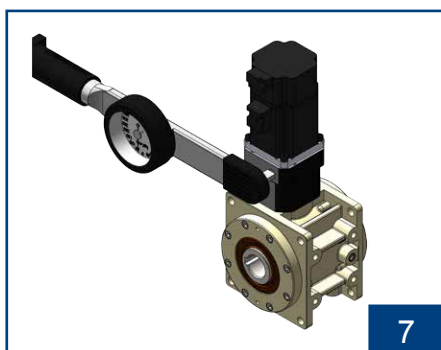

使用扭力扳手將迫緊環螺絲鎖緊。  
Tighten the set collar bolt with torque wrench.

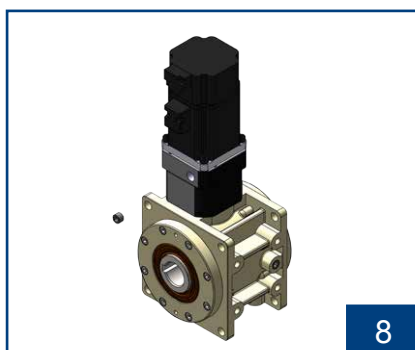

裝回塞頭並鎖緊。  
Tighten back the screw plug.

1. 務必先鎖緊馬達固定面，才能鎖緊馬達軸心迫緊環。  
Please be sure to tighten motor flange on gear box flange first and then to tighten the set collar on motor shaft.
2. 請依步驟順序組裝，尤其步驟 6、7 不可顛倒。  
Please assembly in order according to above steps, especially for step 6 and step 7.
3. 安裝完畢後，請將塞頭回塞，避免細小物品掉入減速機中。  
Please noted that tighten back the screw plug to protect the gear box.