

HY-DN series

RATIO : 5.10.15 (單段 1-Stage)

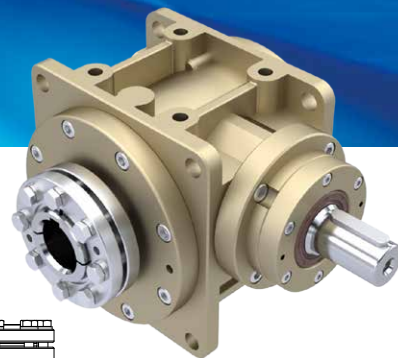

單入力軸心 - 單邊免鍵軸套

Single Input Shaft - Single Clamping

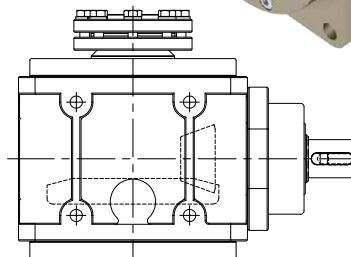
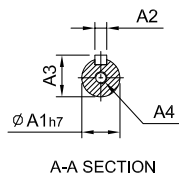
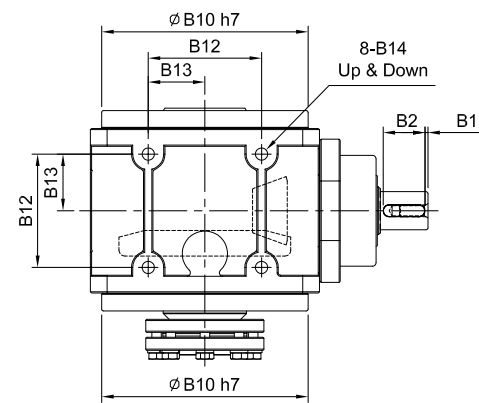

R 軸
Shaft Direction

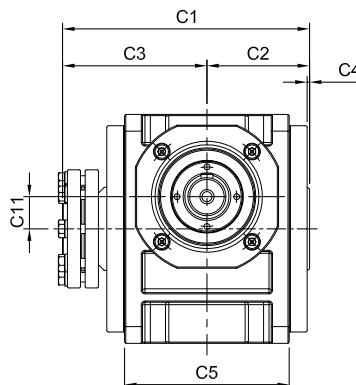
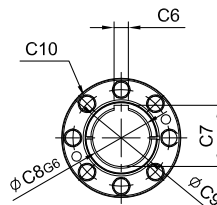
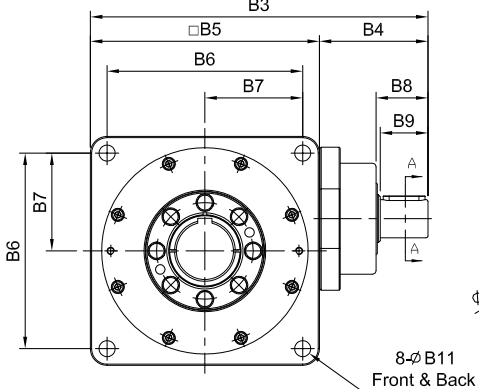

unit: mm

Model Code	55	75	90	115	130	140	160	190	230	270	
A	A1	14	19	24	28	32	32	38	40	55	60
	A2	5	6	8	8	10	10	12	12	16	18
	A3	16	21.5	27	31	35	35	41	43	59	64
	A4	M5 x P0.8	M6 x P1.0	M8 x P1.25	M10 x P1.5	M10 x P1.5	M10 x P1.5	M12 x P1.75	M12 x P1.75	M16 x P2.0	M16 x P2.0
B	B1	2.5	2.5	2.5	2.5	5	5	5	5	5	5
	B2	20	25	35	35	40	40	50	50	70	90
	B3	147	181	218	260	293	315	367	403	483	567
	B4	57	66	78	90	101	100	127	139	183	217
	B5	90	115	140	170	192	215	240	264	300	350
	B6	78	98	118	144	164	182	206	224	260	300
	B7	39	49	59	72	82	91	103	112	130	150
	B8	27	32	42.5	42.5	52.5	51.5	63	63.5	83	105
	B9	25	30	40	40	50	50	60	60	80	100
	B10	84	103	128	148	173	200	227	254	295	328
	B11	6.8	9	11	11	13.5	15	17.5	17.5	17.5	22
	B12	44	54	66	80	95	104	120	140	180	200
	B13	22	27	33	40	47.5	52	60	70	90	100
	B14	M6 x P1.0	M8 x P1.25	M10 x P1.5	M12 x P1.75	M12 x P1.75	M14 x P2.0	M16 x P2.0	M16 x P2.0	M16 x P2.0	M20 x P2.0
C	C1	109	134	160	189	207	224	249	281	344	378
	C2	44	54	66	78	86	93.5	106	121	149	166
	C3	65	80	94	111	121	130.5	143	160	195	212
	C4	2	2	2	2	2	2	2	2	3	3
	C5	60	80	100	120	138	146	166	196	250	280
	C6	6	8	8	12	14	16	18	20	22	25
	C7	22.8	28.3	33.3	43.3	51.8	59.3	64.3	74.9	85.4	95.4
	C8	20	25	30	40	48	55	60	70	80	90
	C9	28	34	44	52	60	73	73	83	100	110
	C10	6-M6	8-M6	8-M6	8-M6	8-M8	12-M8	12-M8	12-M8	12-M10	12-M10
	C11	9	14	18	23	27	32	38	42	50	56
Weight ±3% (kg)	3.2	5.0	9.2	14.8		28.5		54.8			