

HK series

HK

Indication of Model Numbers

機種型號表示

HK	64		B	5	P0
減速機機型 Type	型號 Model	出力表示 Output	軸承形式 Bearing	速比 Ratio	背隙等級 Backlash Class
HK	64 90 110 140 200		B : 滾珠軸承 Ball Bearing T : 滾錐軸承 Taper Bearing	5 10 15	P0 ≤ 3 P1 ≤ 6 P2 ≤ 9



Characteristic of HK Series

HK 系列產品特性

單段減速機 1-Stage

規格 Parameter	Code	Unit	Ratio	64	90	110	140	200
額定輸出扭矩 / Rated Output Torque (Nominal output torque)	T_{2N}	Nm	5	30	70	140	260	720
			10	25	60	117	220	615
			15	20	50	95	180	510
最大加速扭矩 / Max. Acceleration Torque	T_{2B}	Nm	5~15	1.5 倍額定輸出扭矩 1.5 Times of Rated Output Torque				
最大輸出扭矩 / Max. Output Torque 急停扭矩 / Emergency Stop Torque	T_{2NOT}	Nm	5~15	3 倍額定輸出扭矩 3 Times of Rated Output Torque				
額定輸入轉速 / Rated Input Speed	n_{1N}	rpm	5	2,200	1,800	1,500	1,150	700
			10	3,300	2,700	2,200	1,800	1,200
			15	4,000	3,300	2,800	2,300	1,600
最大輸入轉速 / Max. Input Speed	n_{1B}	rpm	5~15	6,000	5,000	4,000	3,000	3,000
背隙 / Backlash	J_t	arcmin	P0	≤ 3	≤ 3	≤ 3	≤ 3	≤ 3
			P1	≤ 6	≤ 6	≤ 6	≤ 6	≤ 6
			P2	≤ 9	≤ 9	≤ 9	≤ 9	≤ 9
容許徑向力 / Max. Radial Force 滾珠軸承 Ball Bearing	F_{2rB}	N	5~15	1,040	2,366	3,900	5,837	7,020
容許軸向力 / Max. Axial Force 滾珠軸承 Ball Bearing	F_{2aB}	N	5~15	520	1183	1950	2919	3,510
容許徑向力 / Max. Radial Force 滾錐軸承 Taper Bearing	F_{2rB}	N	5~15	3,370	6,920	11,300	17,300	20,200
容許軸向力 / Max. Axial Force 滾錐軸承 Taper Bearing	F_{2aB}	N	5~15	1,685	3,460	5,650	8,650	10,100
使用壽命 / Service Life	L_{H1}	hr	5~15	S5 周期運轉 : >30,000 (S1 連續運轉 : >15,000 hrs) S5 Cycle Operation: >30,000 (S1 Continuous Operation: >15,000 hrs)				
效 率 / Efficiency	η	%	5	≥ 96%				
			10~15	≥ 93%				
使用溫度 / Operating Temperature		°C	5~15	-10°C ~ +90°C				
潤 滑 / Lubrication			5~15	全合成潤滑油 Synthetic Oil				
噪 音 值 / Noise Level		dB	5~15	≤ 66	≤ 67	≤ 68	≤ 69	≤ 70

轉動慣量 Mass Moments of Inertia (kgcm²)

Ratio	64	90	110	140	200
5	0.23	0.58	1.41	4.00	13.53
10	0.15	0.38	1.00	2.46	7.38
15	0.13	0.34	0.81	2.07	5.76

HK series

RATIO : 5.10.15 (單段 1-Stage)

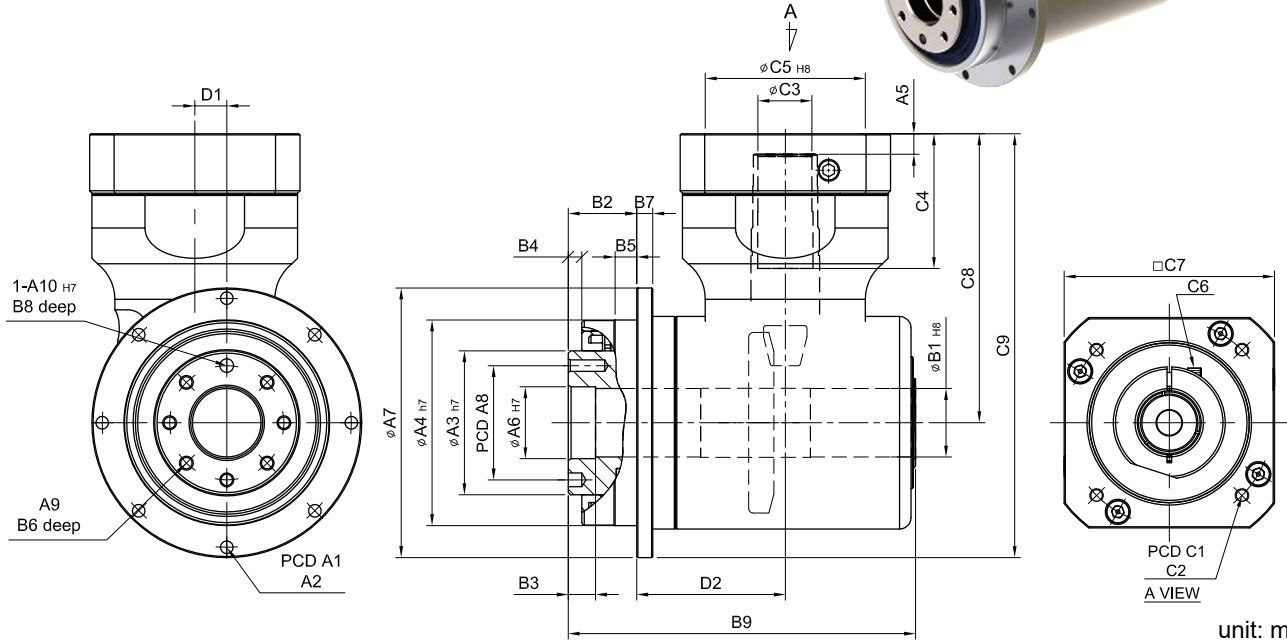

unit: mm

Model Code	64	90	110	140	200
A					
A1	79	109	135	168	233
A2	8-4.5	8-5.5	8-5.5	12-6.6	12-9.0
A3 h7	40	63	80	100	160
A4 h7	64	90	110	140	200
A5	5	6	9	10	10
A6 H7	20	31.5	40	50	80
A7	86	118	146	179	248
A8	31.5	50	63	80	125
A9	7-M5 x P0.8	7-M6 x P1.0	11-M6 x P1.0	11-M8 x P1.25	11-M10 x P1.5
A10 H7	5	6	6	8	10
B					
B1 H8	15	30	30	40	55
B2	18.5	30	29	38	50
B3	10	12	12	12	16
B4	3	6	6	6	8
B5	9.5	10	10	15	15
B6	10	12	12	16	22
B7	5	7	8	10	12
B8	6	6	7	7	10
B9	102.5	152	168	200	260
C					
C1	46 · 60 · 63	90 · 110 · 115 · 145	115 · 145 · 165	115 · 145 · 165	145 · 165 · 200
C2	M3 · M4 · M5	M5 · M6 · M8	M6 · M8 · M10	M6 · M8 · M10	M8 · M10 · M12
C3	11	19 · 24	24 · 32	28 · 35	38 · 42
C4	26	59	67	82	84.5
C5 H8	30 · 40 · 50	70 · 80 · 95 · 110	95 · 110 · 130	95 · 110 · 130	110 · 130 · 180
C6	M3 x P0.5	M6 x P1.0	M8 x P1.25	M8 x P1.25	M10 x P1.5
C7	46 · 55	92 · 110 · 130	122 · 130 · 150	122 · 130 · 150	146 · 150 · 190
C8	69	126.5	149	179	228
C9	112	185.5	222.5	268.5	352.5
C10	1/8"PT	1/8"PT	1/4"PT	1/4"PT	1/4"PT
D					
D1	9	14	18	23	32
D2	43.5	65	77	90	117
Weight ±3% (kg)	1.55	5.26		17	39.3