

MODEL : NEHCGM

搭配微型減速機馬達

In Combination with Compact Gearmotor

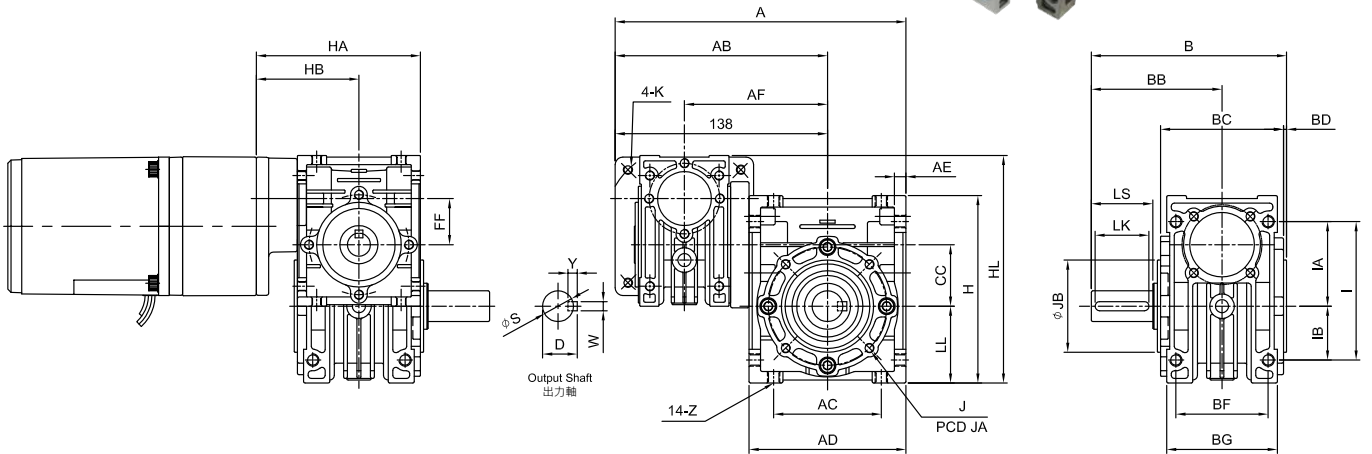
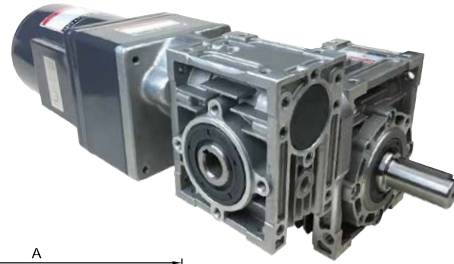

unit: mm

Model	CG	CC	FF	A	AB	AC	AD	AE	AF	B	BB	BC	BD	BF	BG	H	HA	HB	HL	I	IA	IB	LL	Z	出力軸 Output Shaft					Weight (kg)		
																									LS	S	D	WxYxLK	JA		JB	J
40	09	40	30	189	138	70	102	7.5	93	127	85	80	2	60	72	122	105	65	148	90	55	35	50	M8	40	20	22.5	6x6x35	77	60	12-M6	
50	09	50	30	207	147	80	120	8.5	102	150	100	94	3	70	85	145	105	65	168	105	65	40	60	M10	50	25	28	8x7x45	95	70	12-M6	

註：重量不含馬達 NOTE: Weight not include motor.

MODEL : NEOHCGM

搭配微型減速機馬達

In Combination with Compact Gearmotor

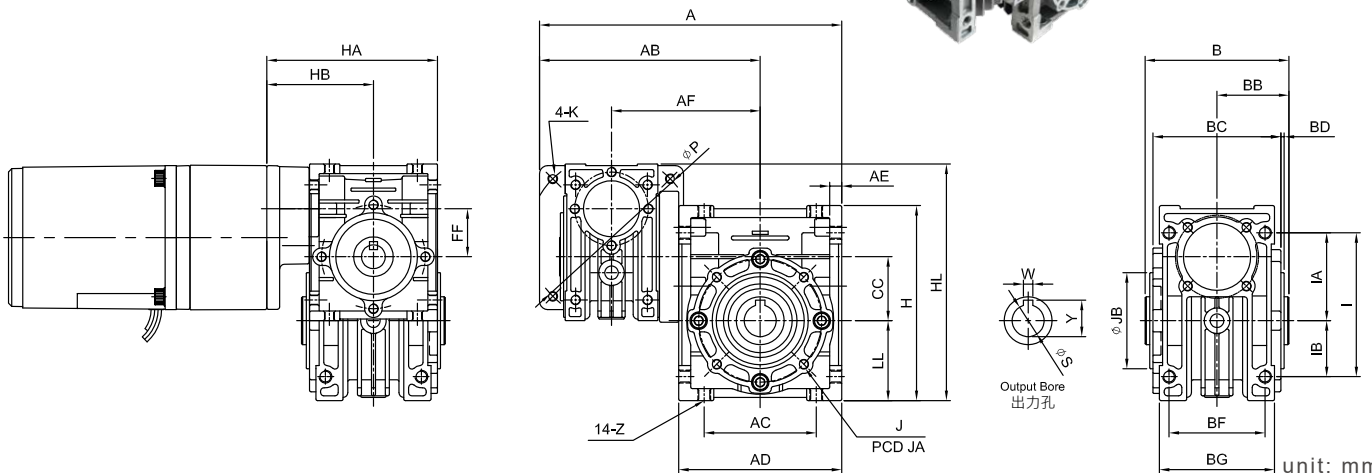
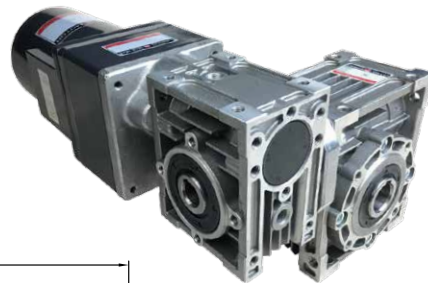

unit: mm

Model	CG	CC	FF	A	AB	AC	AD	AE	AF	B	BB	BC	BD	BF	BG	H	HA	HB	HL	I	IA	IB	LL	Z	出力孔 Output Bore					Weight (kg)	
																									W	S	Y	JA	JB		J
40	09	40	30	189	138	70	102	7.5	93	90	45	80	2	60	72	122	105	65	148	90	55	35	50	M8	6	20	22.8	77	60	12-M6	
50	09	50	30	207	147	80	120	8.5	102	100	50	94	3	70	85	145	105	65	168	105	65	40	60	M10	8	25	28.3	95	70	12-M6	

註：重量不含馬達 NOTE: Weight not include motor.