

MODEL : VMW



▲ 50#~135#



▲ 155#~175#

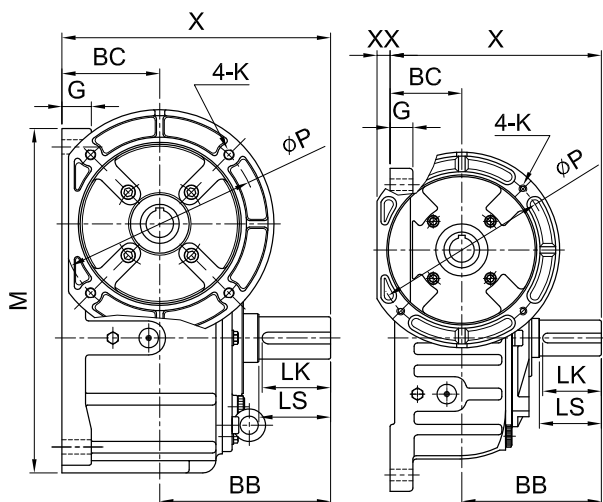
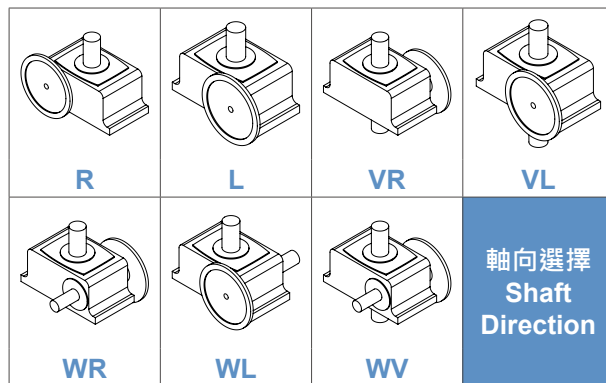

VMW 155~175

VMW 50~135

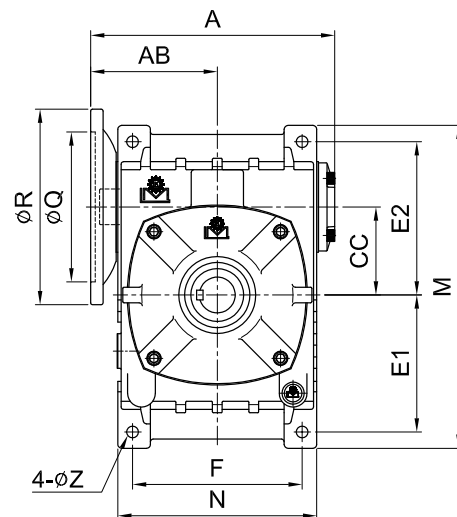
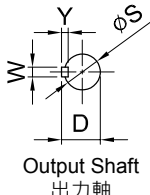
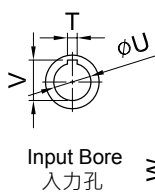

unit: mm

型號 Model	Ratio \ HP		A	AB	X	XX	BB	BC	CC	馬達盤 IEC Motor Flange				腳座 Foot Stock						入力孔 Input Bore			出力軸 Output Shaft				重量 Weight (kg)	
	1/10 ~ 1/30	1/40 ~ 1/60								P	Q	R	K	E1	E2	F	M	N	G	Z	V	T	U	LS	S	D		WxYxLK
50	1/4	-	154	81	148	9	98	50	50	130	110	160	M8	93	102	90	220	118	16	11	12.7	4	11	40	17	19	5x5x35	7.2
60	1/2	1/4	167	86	165	4	110	55	60	130	110	160	M8	105	120	100	252	128	18	11	12.7	4	11	50	22	25	7x7x45	10.2
70	1	1/2	200 206	105 111	195	- 4	130	65	70	130 165	110 130	160 200	M8 M10	120	135	120	288	160	20	15	16.3	5	14	60	28	31	7x7x55	14.4
80	2	1	226	118	210	-	140	70	80	165	130	200	M10	130	150	140	315	183	20	15	21.8	6	19	65	32	35	10x8x60	21.2
100	3	2	279 283	146 150	260	- 8	170	90	100	165 215	130 180	200 248	M10 M12	155	180	190	380	230	26	15	27.3	8	24	75	38	41	10x8x70	43
120	5	3	335	173	290	-	190	100	120	215	180	248	M12	185	215	220	450	266	30	18	31.3	8	28	85	45	48	12x8x80	65
135	7 1/2	5	369	187	324	- 20	214	110	135	215 265	180 230	248 300	M12	210	235	260	495	305	35	18	31.3 41.3	8 10	28 38	95	55	59	15x10x90	85.2
155	10	7 1/2	412	212	393	-	253	140	155	265	230	300	M12	145	265	290	460	340	45	20	41.3	10	38	110	60	64	15x10x105	108
175	15	10	467	236	412	-	262	150	175	265 300	230 250	300 350	M16	167	293	320	516	385	45	22	41.3 45.3	10 12	38 42	110	65	69	18x10x105	150