

2-STAGE WORM REDUCER (WORM+WORM) SERIES

雙段蝸輪減速機 (蝸輪 + 蝸輪) 系列

MODEL : VHM

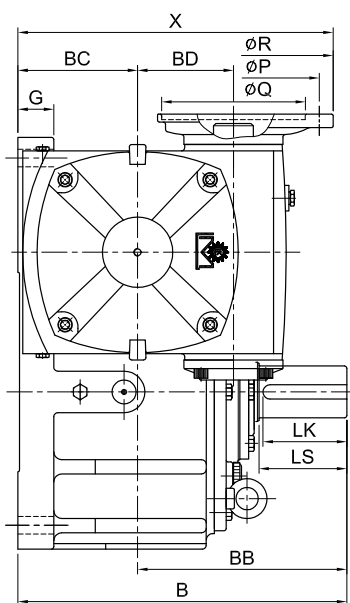
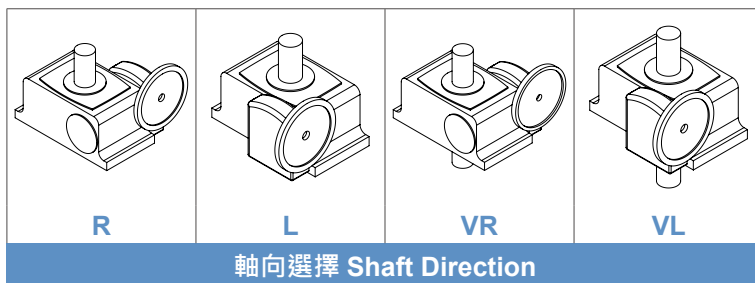
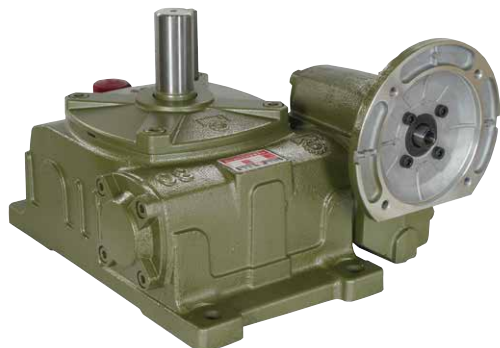

VHM155~175

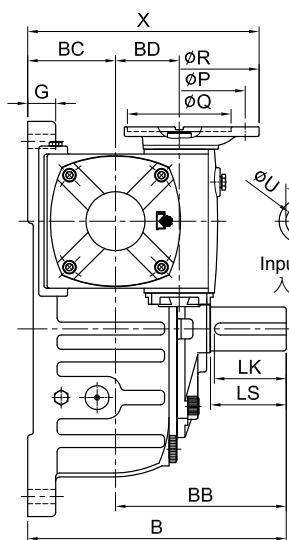

VHM80~135

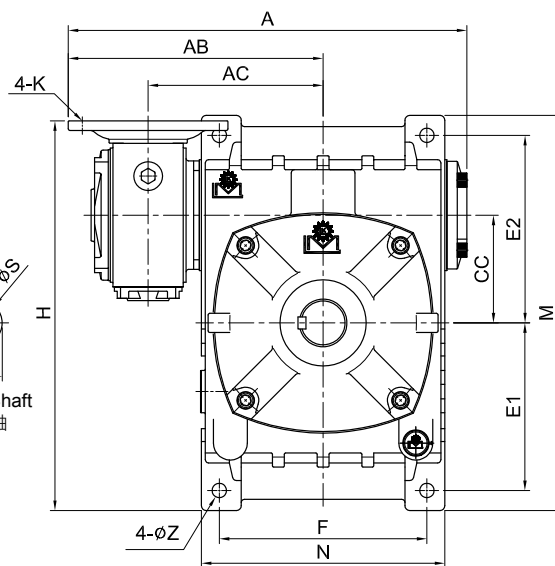

unit: mm

型號 Model	Ratio \ HP		馬達盤 IEC Motor Flange											腳座 Foot Stock					入力孔 Input Bore			出力軸 Output Shaft				重量 Weight (kg)					
	1/100 ~ 1/900	1/1000 ~ 1/3600	A	AB	AC	B	X	BB	BC	BD	CC	H	P	Q	R	K	E1	E2	F	M	N	G	Z	V	T		U	LS	S	D	WxYxLK
80	1/4	-	323	216	136	210	200	140	70	50	80	310	130	110	160	M8	130	150	140	315	183	20	15	12.7	4	11	65	32	35	10x8x60	25.4
100	1/2	1/4	370	238	158	260	230	170	90	60	100	365	130	110	160	M8	155	180	190	380	230	30	15	12.7	4	11	75	38	41	10x8x70	41.2
120	1	1/2	425	265	185	290	250	190	100	70	120	432	130	110	160	M8	185	215	220	450	266	30	18	16.3	5	14	85	45	48	12x8x80	74.8
135	2	1	499	319	219	324	290	214	110	80	135	490	165	130	200	M10	210	235	260	495	305	35	18	21.8	6	19	95	55	59	15x10x90	98.6
155	3	2	557	358	258	393	340	253	140	100	155	471	165	130	200	M10	145	265	290	460	340	45	20	27.3	8	24	110	60	64	15x10x105	124.4
175	5	3	638	408	284	412	395	262	150	120	175	530	215	180	248	M12	167	293	320	516	385	45	20	31.3	8	28	110	65	69	18x10x105	190.4