

WORM REDUCER T SERIES

蝸輪減速機 T 系列

MODEL : TW

R : 右軸 (腳座貼地面, 油鏡端面向自己, 此時輸出端位於右側)

Right Shaft (when facing oil gauge and foot on the ground, output shaft is on the right)

L : 左軸 (腳座貼地面, 油鏡端面向自己, 此時輸出端位於左側)

Left Shaft (when facing oil gauge and foot on the ground, output shaft is on the left)

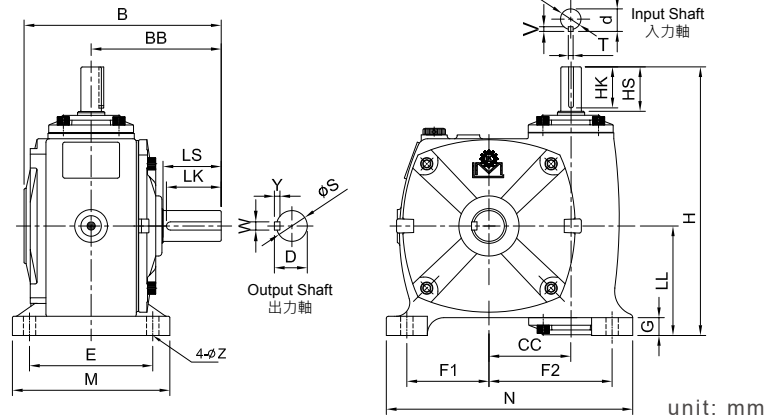
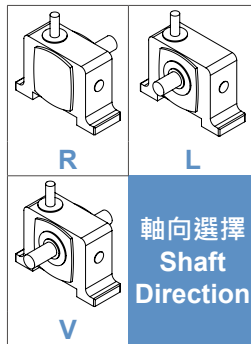

型號 Model	Ratio \ HP		H	LL	CC	B	BB	腳座 Foot Stock							入力軸 Input Shaft				出力軸 Output Shaft				重量 Weight (kg)
	1/10 ~ 1/30	1/40 ~ 1/60						F1	F2	E	M	N	G	Z	HS	U	d	TxVxHK	LS	S	D	WxYxLK	
50	1/4	-	181	76	50	149	98	53	77	100	124	163	16	11	30	12	13.5	4x4x25	40	17	19	5x5x35	7
60	1/2	1/4	210	90	60	165	110	67	98	105	130	200	17	11	40	15	17	5x5x35	50	22	25	7x7x45	9.8
70	1	1/2	236	95	70	189	130	75	115	120	150	230	20	15	40	18	20	5x5x35	60	28	31	7x7x55	13.4
80	2	1	269	105	80	206	140	90	125	125	160	260	20	15	50	22	25	7x7x45	65	32	35	10x8x60	18.4
100	3	2	326	135	100	256	170	100	150	155	195	310	25	15	50	25	28	7x7x45	75	38	41	10x8x70	40.4
120	5	3	392	160	120	286	190	120	180	180	230	360	30	18	65	30	33	7x7x60	85	45	48	12x8x80	57.8
135	7 1/2	5	426	170	135	323	214	130	200	200	250	390	30	18	75	35	38	10x8x70	95	55	59	15x10x90	80

MODEL : TMW

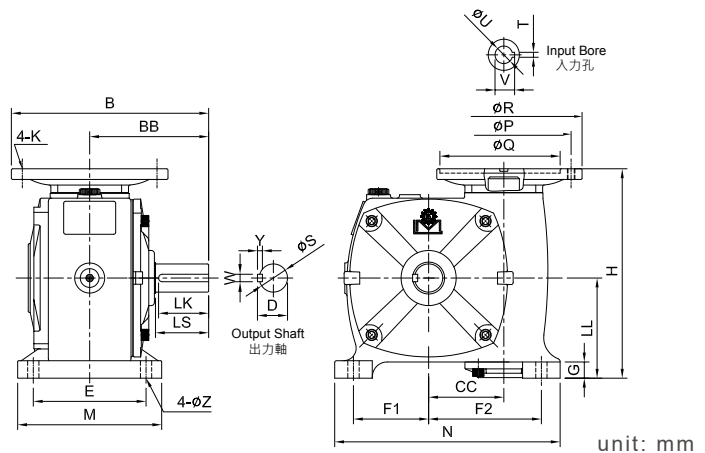
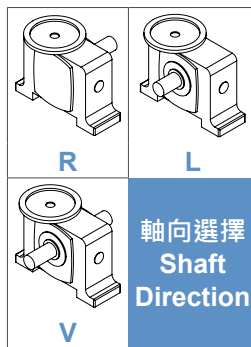

型號 Model	Ratio \ HP		H	LL	CC	B	BB	馬達盤 IEC Motor Flange				腳座 Foot Stock							入力孔 Input Bore			出力軸 Output Shaft				重量 Weight (kg)
	1/10 ~ 1/30	1/40 ~ 1/60						P	Q	R	K	F1	F2	E	M	N	G	Z	V	T	U	LS	S	D	WxYxLK	
50	1/4	-	163	76	50	178	98	130	110	160	M8	53	77	100	124	163	16	11	12.7	4	11	40	17	19	5x5x35	7.8
60	1/2	1/4	177	90	60	190	110	130	110	160	M8	67	98	105	130	200	17	11	12.7	4	11	50	22	25	7x7x45	10.2
70	1	1/2	201 207	95	70	210 230	130	130	110 165	160 200	M8 M10	75	115	120	150	230	20	15	16.3	5	14	60	28	31	7x7x55	15
																			21.7	6	19					
80	2	1	229	105	80	240	140	165	130	200	M10	90	125	125	160	260	20	15	21.7	6	19	65	32	35	10x8x60	20
																			27.2	8	24					
100	3	2	282 286	135	100	270 294	170	165 215	130 180	200 248	M10 M12	100	150	155	195	310	25	15	27.1	8	24	75	38	41	10x8x70	43.4
																			31.3	8	28					
120	5	3	324 360	160	120	315 361	190	215 265	180 230	248 300	M12	120	180	180	230	360	30	18	31.3	8	28	85	45	48	12x8x80	60
																			41.3	8	38					
135	7 1/2	5	360 361	170	135	339 364	214	215 265	180 230	248 300	M12	130	200	200	250	390	30	18	31.3	8	28	95	55	59	15x10x90	80.4
																			41.3	10	38					