

2-STAGE WORM REDUCER (WORM+WORM) SERIES

雙段蝸輪減速機 (蝸輪 + 蝸輪) 系列

MODEL : LOH

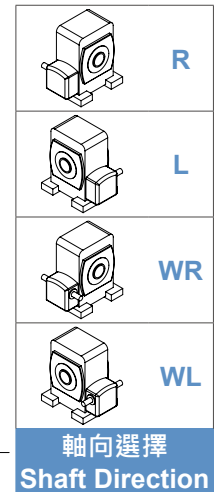
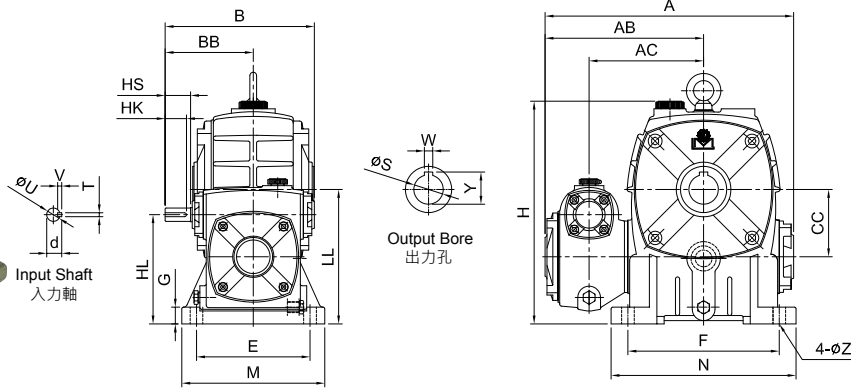

unit: mm

型號 Model	Ratio \ HP		A	AB	AC	B	BB	CC	H	HL	LL	腳座 Foot Stock					入力軸 Input Shaft				出力孔 Output Bore			重量 Weight (kg)	
	1/100 ~ 1/900	1/1000 ~ 1/3600										E	F	M	N	G	Z	HS	U	d	TxVxHK	W	Y		S
60	1/16	-	222	144	100	144	88	60	200	92	120	105	120	130	150	20	11	38	12	13.5	4x4x25	8	28.3	25	13
70	1/8	-	260	165	121	151	86	70	240	110	140	115	150	150	190	20	15	25	12	13.5	4x4x20	8	33.3	30	19.2
80	1/4	-	295	188	136	175	105	80	266	130	160	135	180	170	214	20	15	30	12	13.5	4x4x25	10	38.3	35	26
100	1/2	1/4	346	214	158	210	120	100	337	160	200	155	220	195	270	25	15	40	15	17	5x5x35	10	43.3	40	43.4
120	1	1/2	407	248	185	240	140	120	398	190	240	180	260	230	310	30	18	40	18	20	5x5x35	12	48.3	45	72.6
135	2	1	471	290	219	271	161	135	440	215	270	200	290	250	340	32	18	50	22	25	7x7x45	15	59.3	55	90.6
155	3	2	547	348	258	313.5	190	155	490	235	290	220	320	285	380	38	20	50	25	28	7x7x45	15	69.3	65	113.2
175	5	3	623	393	284	362	231	175	556	280	335	250	350	315	415	40	22	65	30	33	7x7x60	18	94.3	90	200

MODEL : LOHM

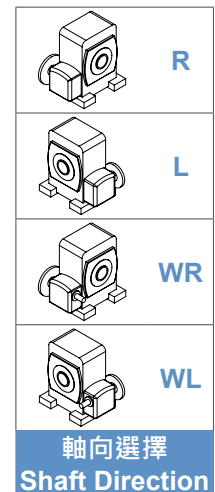
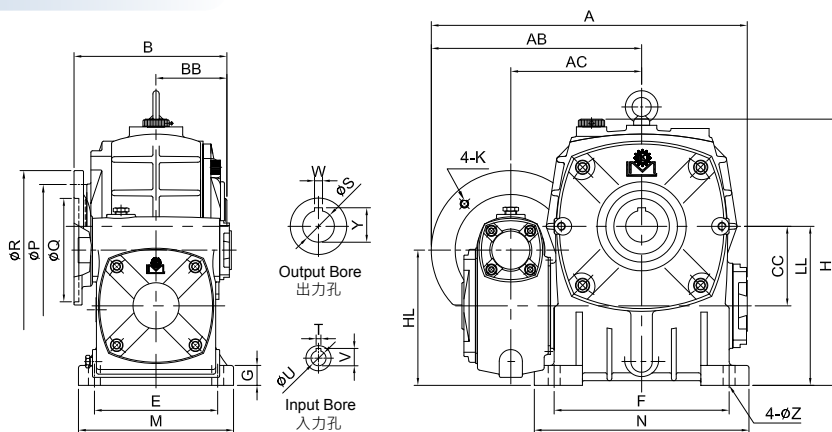

unit: mm

型號 Model	Ratio \ HP		A	AB	AC	B	BB	CC	H	HL	LL	馬達盤 IEC Motor Flange				腳座 Foot Stock					入力孔 Input Bore			出力孔 Output Bore			重量 Weight (kg)	
	1/100 ~ 1/900	1/1000 ~ 1/3600										P	Q	R	K	E	F	M	N	G	Z	V	T	U	W	Y		S
80	1/4	-	324	216	136	151	70	80	266	130	160	130	110	160	M8	135	180	170	214	20	15	12.7	4	11	10	38.3	35	27.4
100	1/2	1/4	371	238	158	176	90	100	337	160	200	130	110	160	M8	155	220	195	270	25	15	12.7	4	11	10	43.3	40	46.4
120	1	1/2	424	265	185	202	100	120	398	190	240	130	110	160	M8	180	260	230	310	30	18	16.3	5	14	12	48.3	45	73
135	2	1	500	319	219	226	110	135	440	215	270	165	130	200	M10	200	290	250	340	32	18	16.3	5	14	15	59.3	55	91.8
155	3	2	557	358	258	267.5	123.5	155	490	235	290	165	130	200	M10	220	320	285	380	38	20	16.3	5	14	15	69.3	65	117.2
175	5	3	645	415	284	295	131	175	556	280	335	215	180	248	M12	250	350	315	415	40	22	27.3	8	24	18	94.3	90	203.4