

MODEL : LH

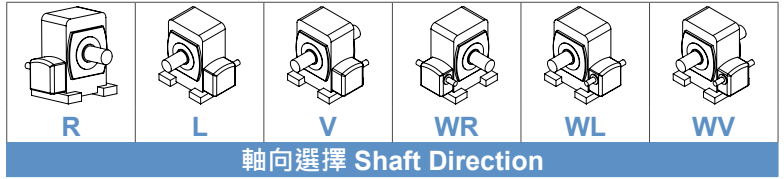

軸向選擇 Shaft Direction

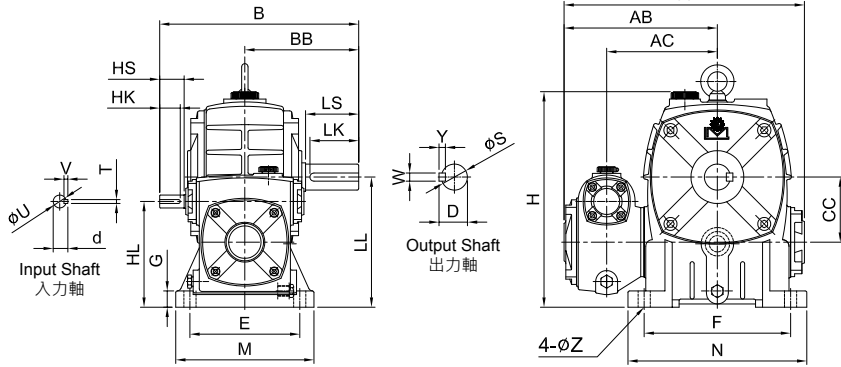

unit: mm

型號 Model	Ratio \ HP		A	AB	AC	B	BB	CC	H	HL	LL	腳座 Foot Stock				入力軸 Input Shaft				出力軸 Output Shaft				重量 Weight (kg)		
	1/100 ~ 1/900	1/1000 ~ 1/3600										E	F	M	N	G	Z	HS	U	d	TxVxHK	LS	S		D	WxYxLK
60	1/16	-	222	144	100	198	110	60	200	92	120	105	120	130	150	20	11	38	12	13.5	4x4x25	50	22	25	7x7x45	11.8
70	1/8	-	260	165	121	216	130	70	240	110	140	115	150	150	190	20	15	25	12	13.5	4x4x20	60	28	31	7x7x55	16.4
80	1/4	-	295	188	136	245	140	80	266	130	160	135	180	170	214	20	15	30	12	13.5	4x4x25	65	32	35	10x8x60	24
100	1/2	1/4	346	214	158	290	170	100	331	160	200	155	220	195	270	25	15	40	15	17	5x5x35	75	38	41	10x8x70	42.6
120	1	1/2	407	248	185	330	190	120	398	190	240	180	260	230	310	30	18	40	18	20	5x5x35	85	45	48	12x8x80	70.6
135	2	1	471	290	219	375	214	135	440	215	270	200	290	250	340	32	18	50	22	25	7x7x45	95	55	59	15x10x90	96.6
155	3	2	547	348	258	443	253	155	490	235	290	220	320	285	380	38	20	50	25	28	7x7x45	110	60	64	15x10x105	118
175	5	3	623	393	284	493	262	175	565	280	335	250	350	315	415	40	22	65	30	33	7x7x60	110	65	69	18x10x105	196.2

MODEL : LHM

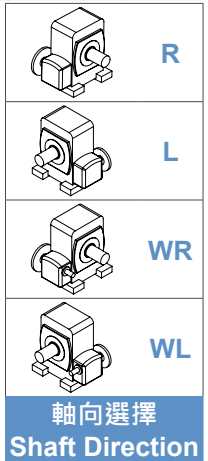
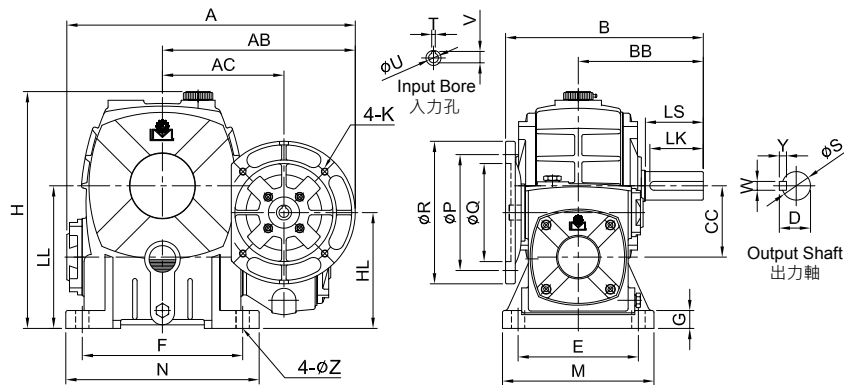

軸向選擇 Shaft Direction

unit: mm

型號 Model	Ratio \ HP		A	AB	AC	B	BB	CC	H	HL	LL	馬達盤 IEC Motor Flange				腳座 Foot Stock				入力孔 Input Bore			出力軸 Output Shaft				重量 Weight (kg)		
	1/100 ~ 1/900	1/1000 ~ 1/3600										P	Q	R	K	E	F	M	N	G	Z	V	T	U	LS	S		D	WxYxLK
80	1/4	-	324	216	136	221	140	80	260	130	160	130	110	160	M8	135	180	170	214	20	15	12.7	4	11	65	32	35	10x8x60	25.6
100	1/2	1/4	371	238	158	256	170	100	337	160	200	130	110	160	M8	155	220	195	270	25	15	12.7	4	11	75	38	41	10x8x70	45.6
120	1	1/2	424	265	185	291	190	120	398	190	240	130	110	160	M8	180	260	230	310	30	18	16.3	5	14	85	45	48	12x8x80	72
135	2	1	500	319	219	330	214	135	440	215	270	165	130	200	M10	200	290	250	340	32	18	16.3	5	14	95	55	59	15x10x90	97.8
155	3	2	557	358	258	397	253	155	490	235	290	165	130	200	M10	220	320	285	380	38	20	16.3	5	14	110	60	64	15x10x105	122
175	5	3	645	415	284	435	262	175	565	280	335	215	180	248	M12	250	350	315	415	40	22	16.3	5	14	110	65	69	18x10x105	199.6