

**MODEL : LD**

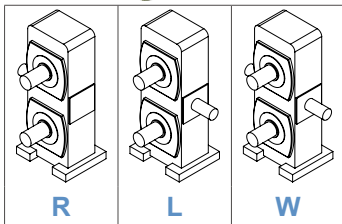

軸向選擇 Shaft Direction

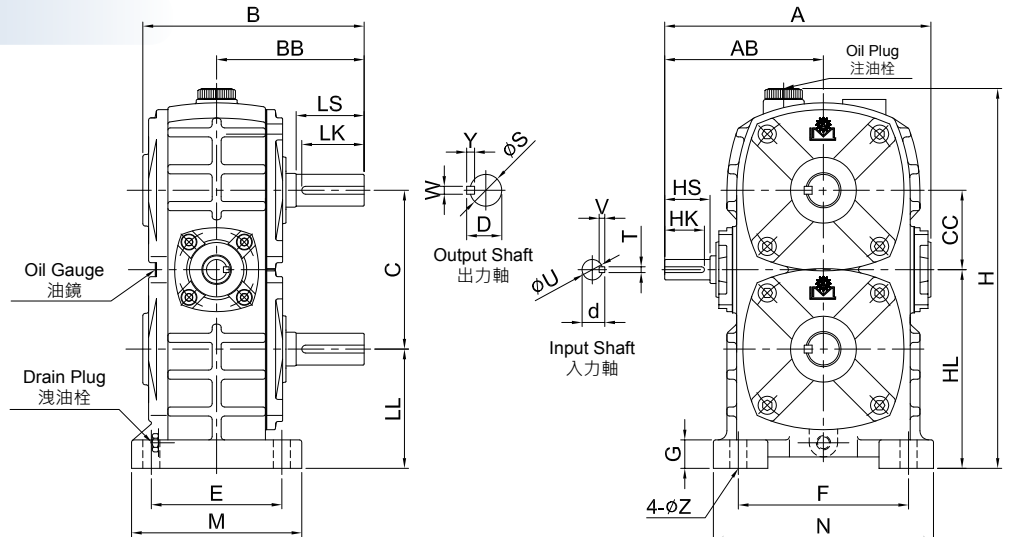

unit: mm

型號 Model	Ratio \ HP		腳座 Foot Stock											入力軸 Input Shaft				出力軸 Output Shaft				重量 Weight (kg)				
	1/10 ~ 1/30	1/40 ~ 1/60	A	AB	B	BB	C	CC	H	HL	LL	E	F	M	N	G	Z	HS	U	d	TxVxHK		LS	S	D	WxYxLK
70	1	1/2	235	140	194	130	140	70	348	175	105	115	150	150	194	25	15	40	18	20	5x5x35	60	28	31	7x7x55	23
80	2	1	268	161	208	140	160	80	378	192	112	135	180	170	220	25	15	50	22	25	7x7x45	65	32	35	10x8x60	30.6
100	3	2	322	190	258	170	200	100	472	250	150	155	220	197	270	27	15	50	25	28	7x7x45	75	38	41	10x8x70	59.4
135	7 1/2	5	435	258	327	214	270	135	636	350	215	200	290	250	350	35	18	75	35	38	10x8x70	95	55	59	15x10x90	135

**MODEL : LDM**

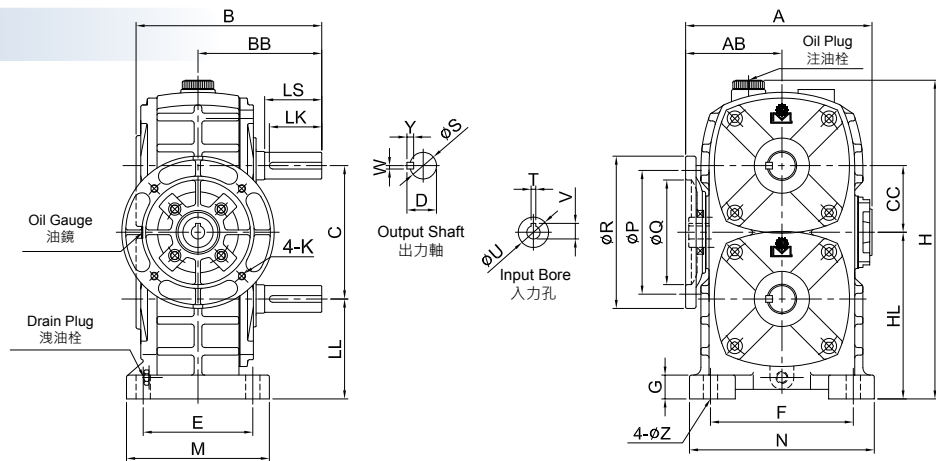

unit: mm

型號 Model	Ratio \ HP		腳座 Foot Stock											入力孔 Input Bore			馬達盤 IEC Motor Flange				出力軸 Output Shaft				重量 Weight (kg)				
	1/10 ~ 1/30	1/40 ~ 1/60	A	AB	B	BB	C	CC	H	HL	LL	E	F	M	N	G	Z	V	T	U	P	Q	R	K		LS	S	D	WxYxLK
70	1	1/2	200	102	108	130	140	70	348	175	105	115	150	150	194	25	15	16.3	5	14	130	110	160	M8	60	28	31	7x7x55	24.6
80	2	1	223	118	208	140	160	80	378	192	112	135	180	170	220	25	15	21.8	6	19	165	130	200	M10	65	32	35	10x8x60	32
																		27.3	8	24	165	130	200	M10					
100	3	2	278	146	258	170	200	100	472	250	150	155	220	197	270	27	15	27.3	8	24	165	130	200	M10	75	38	41	10x8x70	62.4
																		31.3	8	28	215	180	250	M12					
135	7 1/2	5	370	193	327	214	270	135	636	350	215	200	290	250	350	35	18	31.3	8	28	215	180	250	M12	95	55	59	15x10x90	142
			371	194														41.3	10	38	265	230	300	M12					