

1-STAGE WORM REDUCER W SERIES

單段蝸輪減速機 W 系列

MODEL : HOM



Model	N
50	140
60	150
70	190
80	217
100	270
120	310
135	340
155	380
175	415

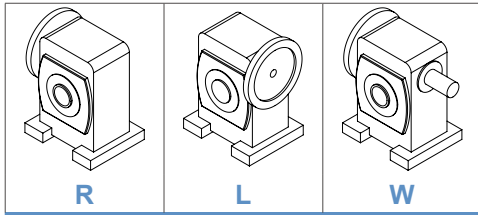
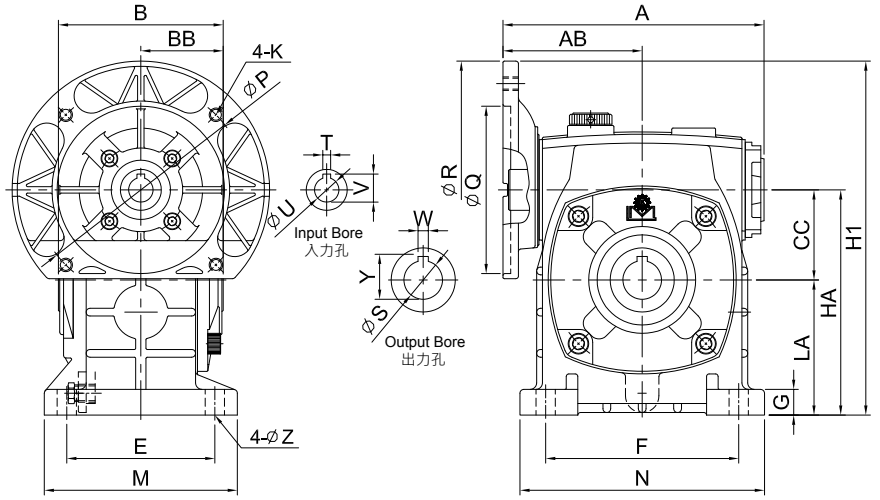

軸向選擇 Shaft Direction

MODEL : LOM



Model	N
50	140
60	150
70	190
80	214
100	270
120	310
135	340
155	380
175	415

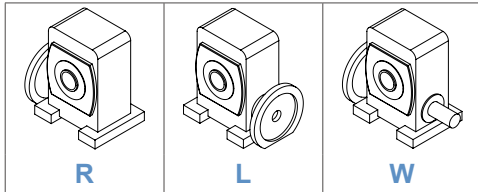
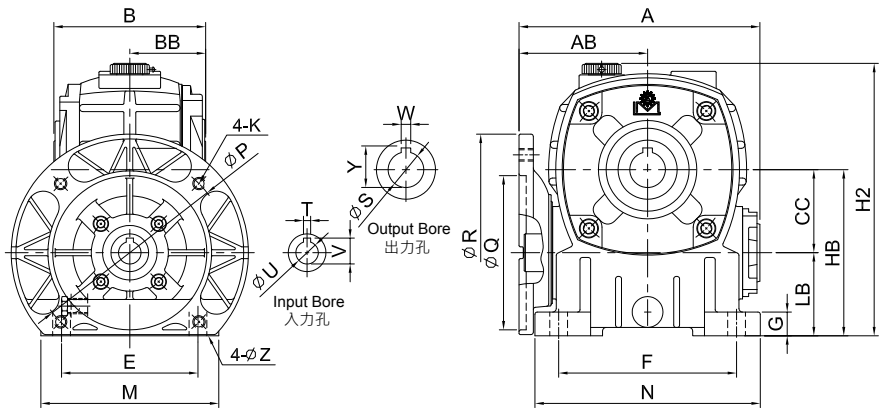

軸向選擇 Shaft Direction

unit: mm

型號 Model	Ratio \ HP		A	AB	B	BB	CC	H1	H2	HA	HB	LA	LB	馬達盤 IEC Motor Flange				腳座 Foot Stock				入力孔 Input Bore			出力孔 Output Bore			重量 Weight (kg)	
	1/10 ~ 1/30	1/40 ~ 1/60												P	Q	R	K	E	F	M	G	Z	V	T	U	W	Y		S
50	1/4	-	154	81	98	49	50	210	172	130	100	80	50	130	110	160	M8	95	110	120	16	11	12.7	4	11	6	22.8	20	8
60	1/2	1/4	165	87	108	54	60	230	200	150	120	90	60	130	110	160	M8	105	120	130	20	11	12.7	4	11	8	28.3	25	10.6
70	1	1/2	200	105	128	64	70	255	235	175	140	105	70	130	110	160	M8	115	150	150	18	15	16.3	5	14	8	33.3	30	18
			206	111				275						130	130	200							M10	21.8	6				
80	2	1	229	121	138	69	80	300	260	200	160	120	80	165	130	200	M10	135	180	170	20	15	21.8	6	19	10	38.3	35	23.2
100	3	2	279	146	178	89	100	350	337	250	200	150	100	165	130	200	M10	155	220	195	25	15	27.3	8	24	10	43.3	40	40.8
			283	150				375						165	180	248							M12	31.3	8				
120	5	3	333	173	198	99	120	425	398	300	240	180	120	215	180	248	M12	180	260	230	30	18	31.3	8	28	12	48.3	45	68.2
			475	440				350						270	215	135							215	180	248				
155	10	7 1/2	412	212	247	123.5	155	540	482	390	290	235	135	265	230	300	M12	220	320	285	35	20	41.3	10	38	15	69.3	65	113.4
			585	482				390						290	235	135							265	230	300				
175	15	10	467	236	262	131	175	610	565	435	335	260	160	265	230	300	M16	250	350	315	40	22	41.3	10	38	18	94.3	90	158.6