

### MODEL : EOH

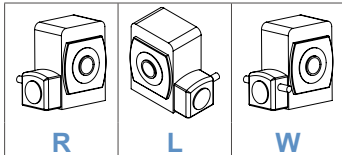

軸向選擇 Shaft Direction

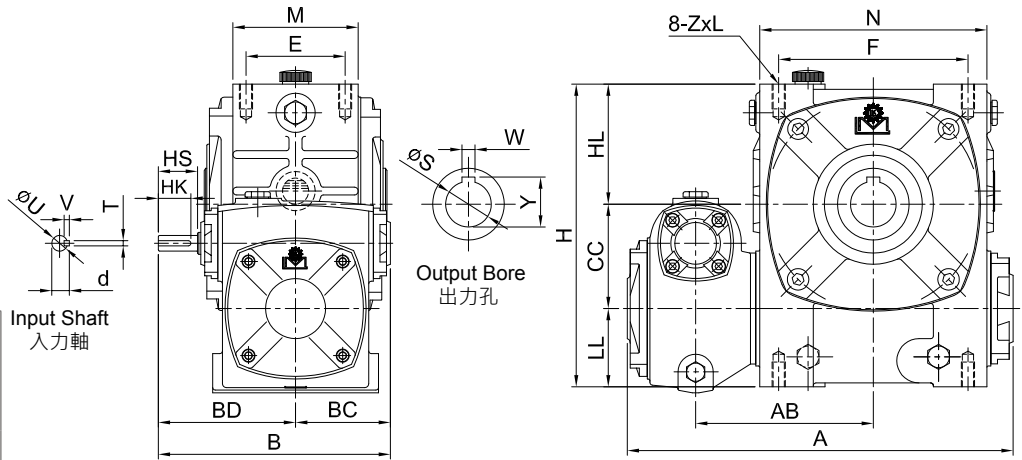

unit: mm

型號 Model	Ratio \ HP		A	AB	B	BC	BD	CC	LL	HL	H	腳座 Foot Stock				入力軸 Input Shaft				出力孔 Output Bore			重量 Weight (kg)	
	1/100 ~ 1/900	1/1000 ~ 1/3600										E	F	M	N	ZxL	HS	U	d	TxVxHK	W	Y		S
60	1/16	-	218	100	144	55	86	60	42	75	177	55	100	77	125	M10x20	25	12	13.5	4x4x25	8	28.3	25	13.2
70	1/8	-	260	121	151	65	86	70	50	85	205	65	125	87	158	M10x20	25	12	13.5	4x4x20	8	33.3	30	17.2
80	1/4	-	295	136	175	70	105	80	60	92	232	75	145	98	175	M10x20	30	12	13.5	4x4x25	10	38.3	35	25.4
100	1/2	1/4	346	158	210	90	120	100	75	115	290	85	185	117	226	M12x24	40	15	17	5x5x35	10	43.3	40	42.6
120	1	1/2	407	185	240	100	140	120	95	155	370	100	220	132	264	M14x28	40	18	20	5x5x35	12	48.3	45	68
135	2	1	471	219	271	110	161	135	105	185	425	110	260	150	306	M16x35	50	22	25	7x7x45	15	59.3	55	91.2

### MODEL : EOHM

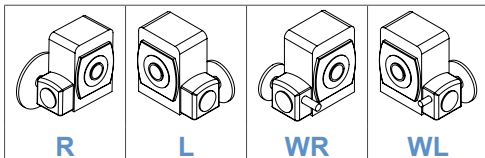

軸向選擇 Shaft Direction

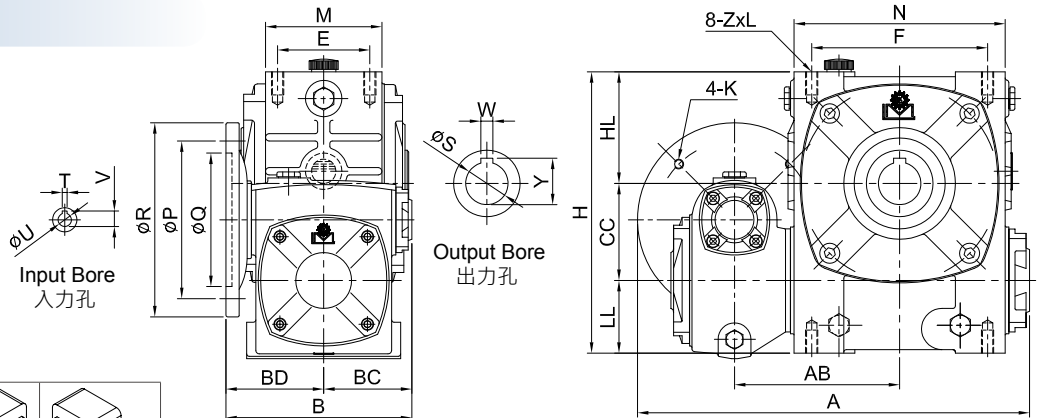

unit: mm

型號 Model	Ratio \ HP		A	AB	B	BD	BC	CC	LL	HL	H	馬達盤 IEC Motor Flange				腳座 Foot Stock				入力孔 Input Bore			出力孔 Output Bore			重量 Weight (kg)	
	1/100 ~ 1/900	1/1000 ~ 1/3600										P	Q	R	K	E	F	M	N	ZxL	V	T	U	W	Y		S
80	1/4	-	323	136	151	81	70	80	60	92	232	130	110	160	M8	75	145	98	175	M10x20	12.7	4	11	10	38.3	35	26
100	1/2	1/4	370	158	176	86	90	100	75	115	290	130	110	160	M8	85	185	117	226	M12x24	12.7 16.3	4 5	11 14	10	43.3	40	45.6
120	1	1/2	424 444	185	202	102	100	120	95	155	370	130 165	110 130	160 200	M8 M10	100	220	132	264	M14x28	16.3 21.8	5 6	14 19	12	48.3	45	69.4
135	2	1	499	219	226	116	110	135	105	185	425	165	130	200	M10	110	260	150	306	M16x35	21.8 27.3	6 8	19 24	15	59.3	55	92.4