

MODEL : EM

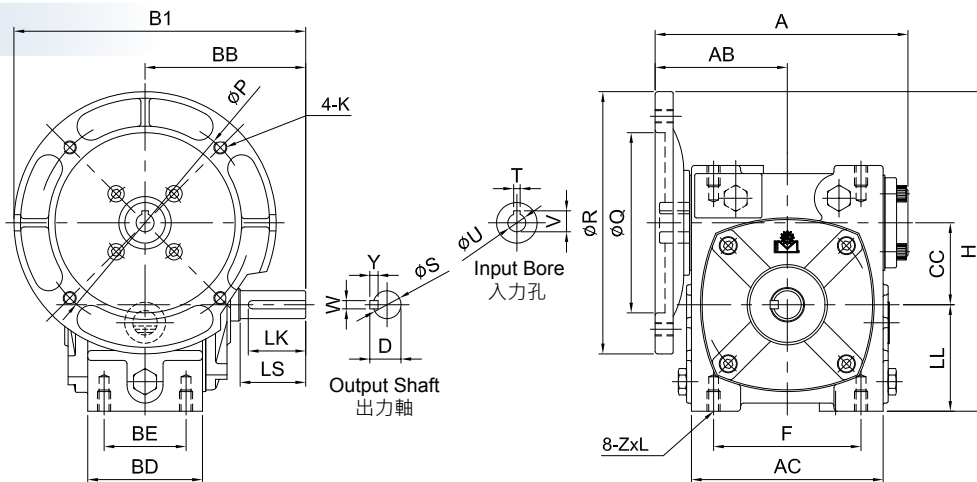

MODEL : EOM

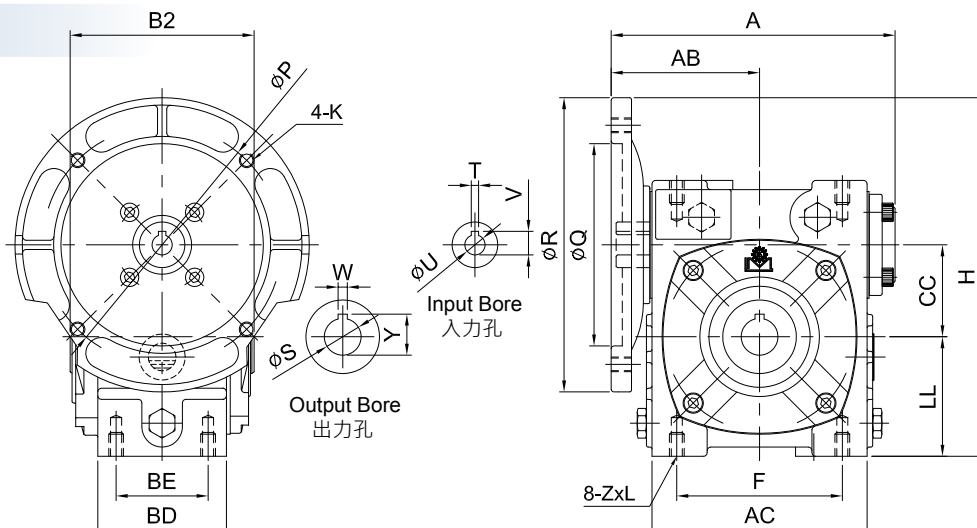

unit: mm

型號 Model	出力孔 Output Bore		
	S	W	Y
50	20	6	22.8
60	25	8	28.3
70	30	8	33.3
80	35	10	38.3
100	40	10	43.3
120	45	12	48.3
135	55	15	59.3

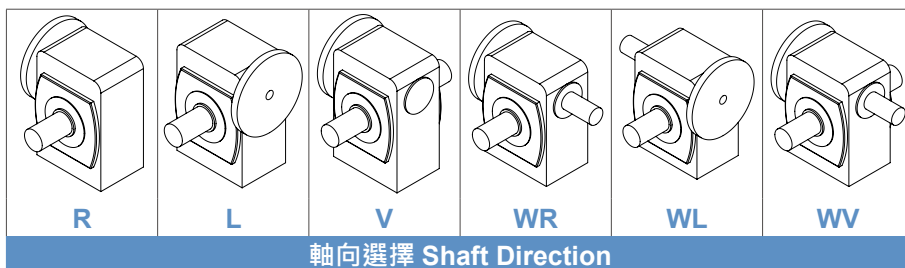

軸向選擇 Shaft Direction

unit: mm

型號 Model	Ratio \ HP		腳座 Foot Stock								馬達盤 IEC 及入力孔 Motor Flange & Input Bore								出力軸 Output Shaft						重量 Weight (kg)			
	1/10~ 1/30	1/40~ 1/60	A	AB	B1	B2	BB	CC	LL	H	AC	F	BD	BE	ZxL	P	Q	R	K	V	T	U	LS	S	D	WxYxLK	EM	EOM
	50	1/4	-	154	81	178	98	98	50	65	195	115	90	70	50	M8x16	130	110	160	M8	12.7	4	11	40	17	19	5x5x35	6.6
60	1/2	1/4	165	87	190	108	110	60	75	215	124	100	77	55	M10x18	130	110	160	M8	12.7	4	11	50	22	25	7x7x45	9.4	10.6
70	1	1/2	200	105	210	128	130	70	85	235	154	125	85	65	M10x18	130	110	160	M8	16.3	5	14	60	28	31	7x7x55	15.6	15.4
			206	111	230					165						130	200	M10	21.8	6	19							
80	2	1	229	121	240	138	140	80	92	272	174	145	96	75	M10x18	165	130	200	M10	21.7	6	19	65	32	35	10x8x60	20	22
			284	150	295					27.2						8	24											
100	3	2	280	146	270	178	170	100	115	315	225	185	116	85	M12x20	165	130	200	M10	27.1	8	24	75	38	41	10x8x70	37.8	38.4
			340	215	180					248						M12	31.3	8	28									
120	5	3	333	173	315	198	190	120	155	400	264	220	132	100	M14x28	215	180	248	M12	31.3	8	28	85	45	48	12x8x80	60.2	61.6
			339	215	180					248						M12	31.3	8	28									
135	7 1/2	5	374	193	339	218	214	135	185	445	306	260	150	110	M16x30	215	180	248	M12	31.3	8	28	95	55	59	15x10x90	81.6	84
			364	265	230					300						M12	41.3	10	38									