

MODEL : TS85

RATIO : 13.1、16.1、20.7、23、25、32、48

用途：電動代步車傳動軸

型式：差速器（大型車）

段數：2 段平行齒輪 +4 只傘齒輪

Application: Transaxle for Powered Scooter

Specification: Differential Gear

Stage: 2 stage, helical gear + bevel gear



TS85

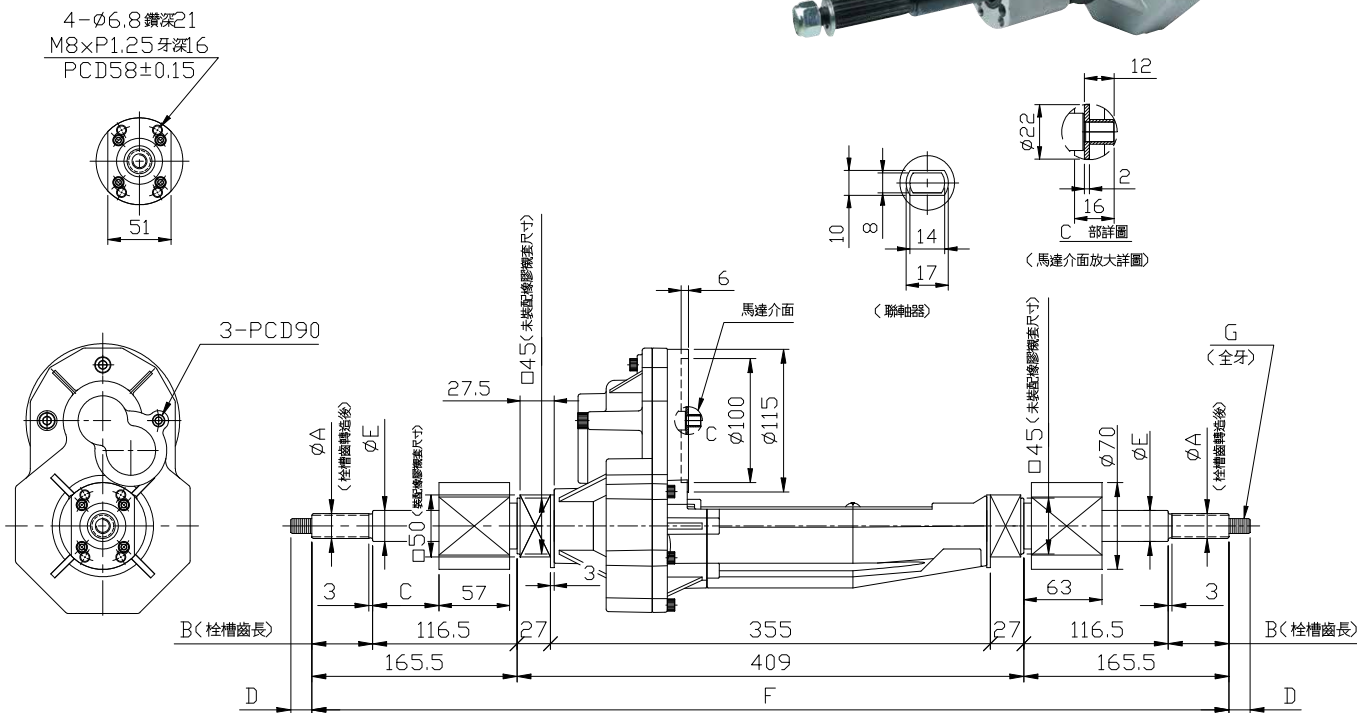

說明：參考載重（機台重量 100kg+ 使用者載重 250kg）= 總重 ≤ 350kg

Max. Loading capacity : Wheel chair 100kg+ Personnel 250kg ≤ 350kg

NO	A	B	C	D	E	F	G
規格說明	≤ Φ20	≤ 49	≤ 53.5	≤ 20	≤ Φ25	≤ 740	≤ M12

規格 Model No.	Unit	Ratio							
		13.1	16.1	20.7	23	25	32	48	
額定輸出扭矩 (額定 / 連續運轉) Rated Output Torque	Nm	80	80	80	95	115	115	115	
最大輸出扭矩 (急停 / 瞬間啟動) Max. Output Torque	Nm	3 倍額定輸出扭矩 3 Times of Rated Output Torque							
額定輸入轉速 Rated Input Speed	rpm	4,700							
最大輸入轉速 Max. Input Speed	rpm	5,300							
馬達額定功率 (僅供參考) Motor Rated Input Power	W	1000W	1000W	1000W	800W	800W	800W	800W	
噪音值 Noise Level(量測距離 30cm)	dB	≤ 72	≤ 72	≤ 72	≤ 70	≤ 70	≤ 70	≤ 70	
容許徑向力 Max. Radial Force	kgf	580							
容許軸向力 Max. Axial Force	kgf	270							
效率 Efficiency	%	≥ 90	≥ 90	≥ 90	≥ 90	≥ 90	≥ 90	≥ 90	
使用溫度 Operating Temperature	°C	-15°C ~ +80°C							
減速機重量 Reducer Weight ±3%	Kg	9.5							