

MODEL : MD50C

RATIO : 17、19.3

用途：電動輪椅傳動軸

型式：180 度型 [中型直結式] 減速機

段數：1 段平行齒輪

Application: Transaxle for Powered Wheelchair

Specification: Parallel Shaft

Stage: 1 stage, Helical gear

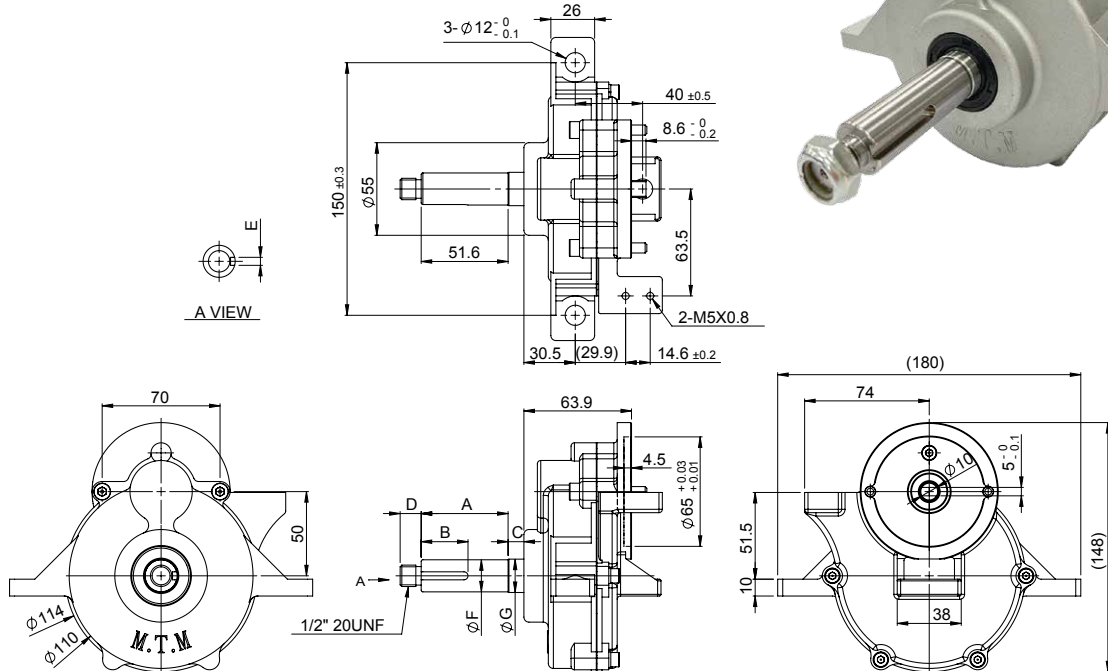
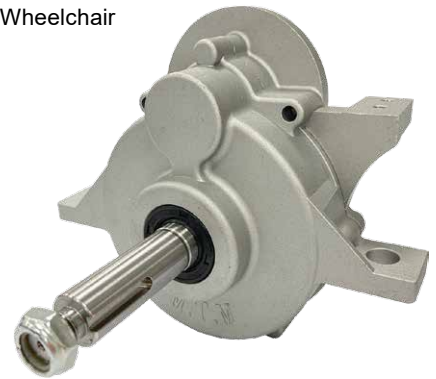

說明：參考載重 (機台重量 80kg+ 使用者載重 140kg) = 總重 ≤ 220kg (2 台)
 載重能力僅供參考，不在保證項目，請依實測為準。

Max. Loading capacity : Wheel chair 80kg+ Personnel 140kg ≤ 220kg (2 pieces)

Load capacity is for reference only, not guaranteed items, please refer to actual measurement.

NO	A	B	C	D	E	F	G
規格說明	≤ 60	≤ 55	≤ 10	≤ 18	≤ 6	≤ Φ20	≤ Φ20

規格 Model No.	Ratio		17	19.3			
	Unit						
額定輸出扭矩 (額定 / 連續運轉) Rated Output Torque	Nm		30	35			
最大輸出扭矩 (急停 / 瞬間啟動) Max. Output Torque	Nm		3 倍額定輸出扭矩 3 Times of Rated Output Torque				
額定輸入轉速 Rated Input Speed	rpm		3,500				
最大輸入轉速 Max. Input Speed	rpm		4,500				
馬達額定功率 (僅供參考) Motor Rated Input Power	W		300	300			
噪音值 Noise Level(量測距離 30cm)	dB		≤ 62	≤ 62			
容許徑向力 Max. Radial Force	kgf		250				
容許軸向力 Max. Axial Force	kgf		120				
效率 Efficiency	%		≥ 95	≥ 95			
使用溫度 Operating Temperature	°C		-15°C ~ +80°C				
減速機重量 Reducer Weight ±3%	Kg		1.8				