

# MODEL : MD50A

RATIO : 17、19.3

用途：電動輪椅傳動軸

型式：180 度型 [ 中型直結式 ] 減速機

段數：1 段平行齒輪

Application: Transaxle for Powered Wheelchair

Specification: Parallel Shaft

Stage: 1 stage, Helical gear

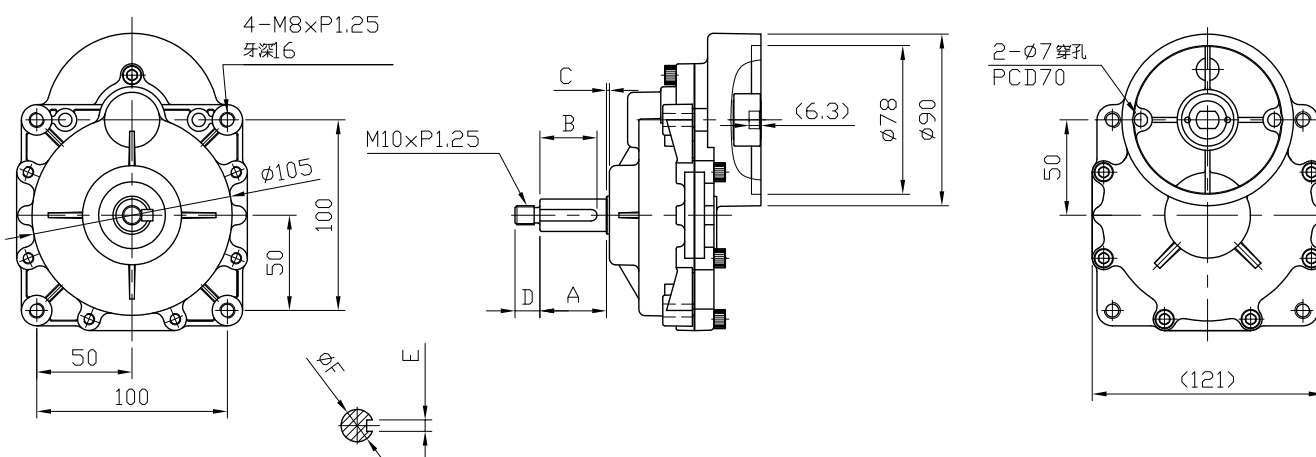

說明：參考載重 ( 機台重量 80kg+ 使用者載重 140kg ) = 總重  $\leq 220$ kg ( 2 台 )  
載重能力僅供參考，不在保證項目，請依實測為準。

Max. Loading capacity : Wheel chair 80kg+ Personnel 140kg  $\leq 220$ kg ( 2 pieces )

Load capacity is for reference only, not guaranteed items, please refer to actual measurement.

NO	A	B	C	D	E	F	G
規格說明	$\leq 60$	$\leq 55$	$\leq 10$	$\leq 18$	$\leq 6$	$\leq \Phi 20$	$\leq \Phi 20$

規格 Model No.	Ratio		17	19.3				
	Unit							
額定輸出扭矩 ( 額定 / 連續運轉 ) Rated Output Torque	Nm		30	35				
最大輸出扭矩 ( 急停 / 瞬間啟動 ) Max. Output Torque	Nm		3 倍額定輸出扭矩 3 Times of Rated Output Torque					
額定輸入轉速 Rated Input Speed	rpm					3,500		
最大輸入轉速 Max. Input Speed	rpm					4,500		
馬達額定功率 ( 僅供參考 ) Motor Rated Input Power	W		300	300				
噪音值 Noise Level ( 量測距離 30cm )	dB		$\leq 62$	$\leq 62$				
容許徑向力 Max. Radial Force	kgf					600		
容許軸向力 Max. Axial Force	kgf					330		
效率 Efficiency	%		$\geq 95$	$\geq 95$				
使用溫度 Operating Temperature	$^{\circ}\text{C}$		-15 $^{\circ}\text{C}$ ~ +80 $^{\circ}\text{C}$					
減速機重量 Reducer Weight $\pm 3\%$	Kg		1.8					