

電梯主機 Traction Machine

PS-3200^{CE}

■產品特性 Features

主軸靜荷重 Max. Static Load:	3,200 kg
最大升降行程 Allowable Travel (m):	30M
重量約 Weight:	270 kg
馬達額定電壓 Motor Rated Voltage:	208V / 360V
馬達額定電流 Motor Rated Current:	26.1A / 15.1A
馬達絕緣等級 Motor INS. Class:	F
制動器電壓 Brake Voltage:	DC 110V
編碼器 Encoder:	ø30 中空型 (Central Through Type) 1024 P/R
編碼器電壓 Encoder Voltage:	DC 7~24V

■主槽輪向選擇 M/Sheave Direction

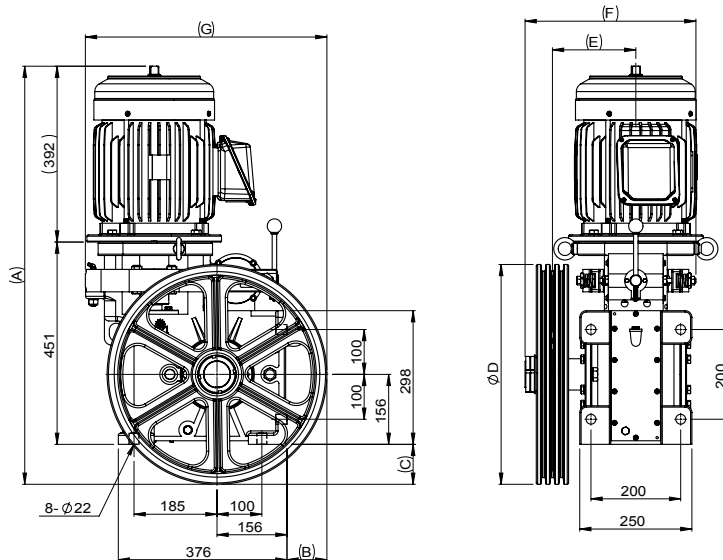
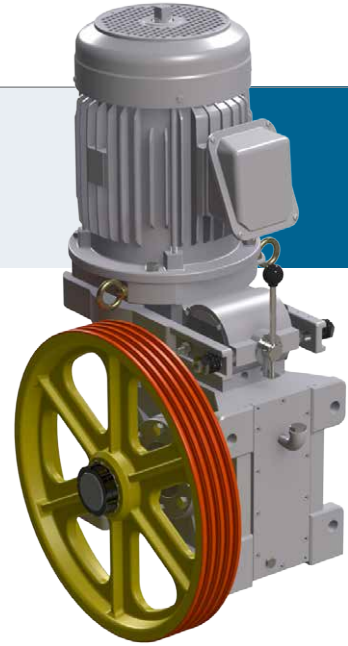
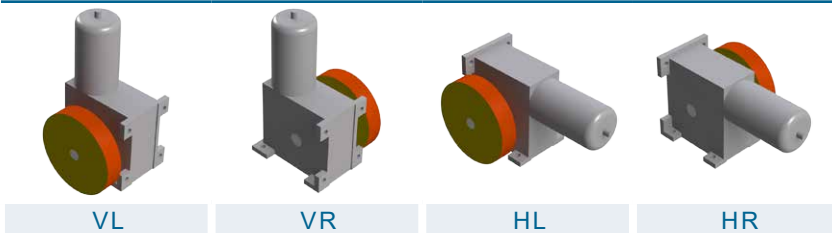

載重 Duty Load (kg)	速度 Speed (m/min)	掛比 Roping	減速比 Ratio	主槽輪 M / Sheave							馬達 Motor					
				節徑 Dia. (PCD) (mm)	鋼索 Rope (mm)	槽距 Pitch (mm)	尺寸表 Dimension							功率 Power (kW)	極數 Poles (P)	頻率 Frequency (Hz)
							A	B	C	D	E	F	G			
550	30	1:1	1:41	ø400	ø10 X 4	16	890	47	47	405	186	381	496	5.5	4	33
550	45	1:1	1:37	ø400	ø10 X 4	16	890	47	47	405	186	381	496	5.5	4	44
550	45	1:1	1:41	ø485	ø10 X 3-4 / ø12 X 3	16 / 20	932	89	89	490	186	381	539	5.5	4	41
550	60	1:1	1:37	ø485	ø10 X 3-4 / ø12 X 3	16 / 20	932	89	89	490	186	381	539	5.5	4	49
550	30	2:1	2:41	ø400	ø10 X 4	16	890	47	47	405	186	381	496	5.5	4	33
550	45	2:1	2:37	ø400	ø10 X 4	16	890	47	47	405	186	381	496	5.5	4	44
550	45	2:1	2:41	ø485	ø10 X 3-4 / ø12 X 3	16 / 20	932	89	89	490	186	381	539	5.5	4	41
550	45	2:1	2:41	ø510	ø10 X 4	16	945	102	102	515	192	394	551	5.5	4	39
550	60	2:1	2:37	ø485	ø10 X 3-4 / ø12 X 3	16 / 20	932	89	89	490	186	381	539	5.5	4	49
550	60	2:1	2:37	ø510	ø10 X 4	16	945	102	102	515	192	394	551	5.5	4	46
800	30	2:1	1:37	ø485	ø10 X 3-4 / ø12 X 3	16 / 20	932	89	89	490	186	381	539	5.5	4	49