

電梯主機 Traction Machine

P20-7000^{CE}

■產品特性 Features

主軸靜荷重 Max. Static Load:	7,000 kg
最大升降行程 Allowable Travel (m):	40M
重量約 Weight:	820 kg
馬達額定電壓 Motor Rated Voltage:	208V / 360V
馬達額定電流 Motor Rated Current:	18.5kW = 65.8A / 38.2A ; 22kW = 77.2A / 44.8A
馬達絕緣等級 Motor INS. Class:	F
制動器電壓 Brake Voltage:	DC 110V
編碼器 Encoder:	ø30 中空型 (Central Through Type) 1024 P/R
編碼器電壓 Encoder Voltage:	DC 7~24V

■主槽輪向選擇 M/Sheave Direction

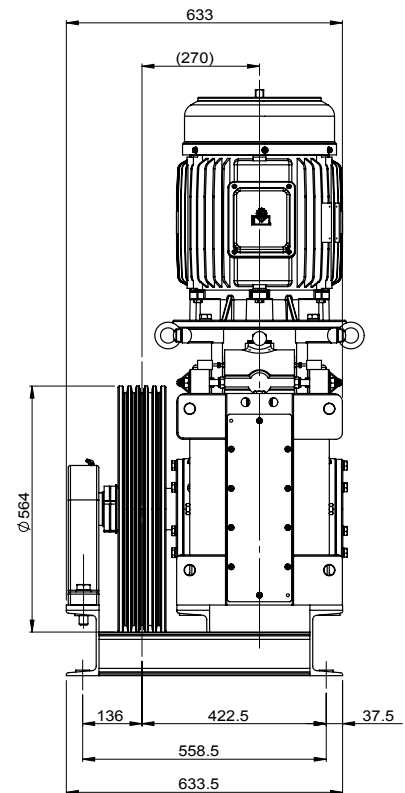
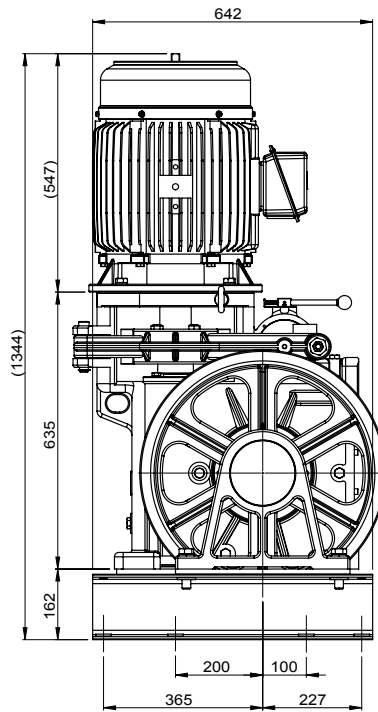
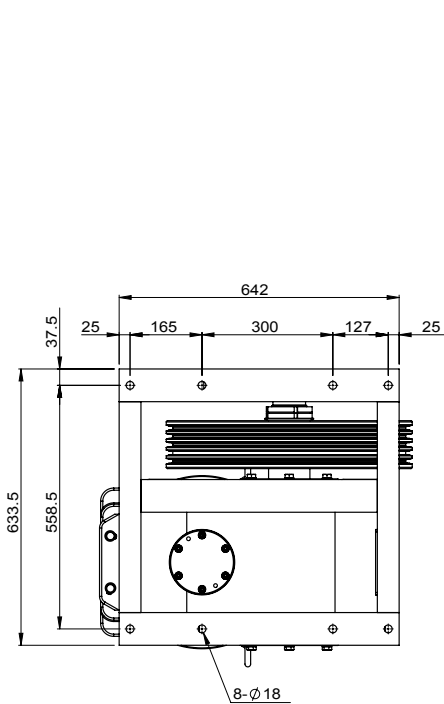
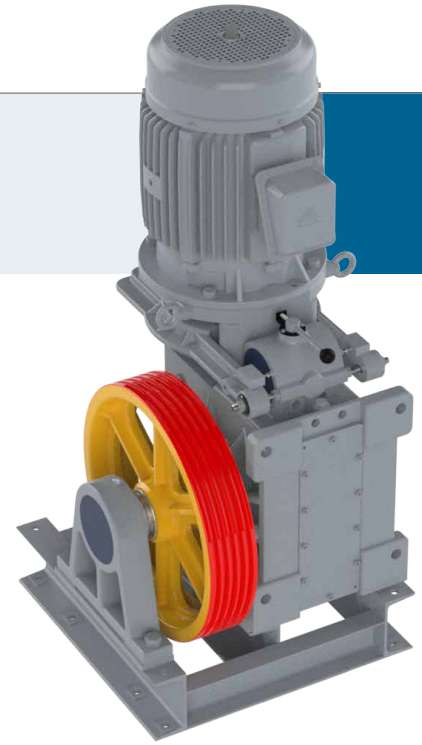
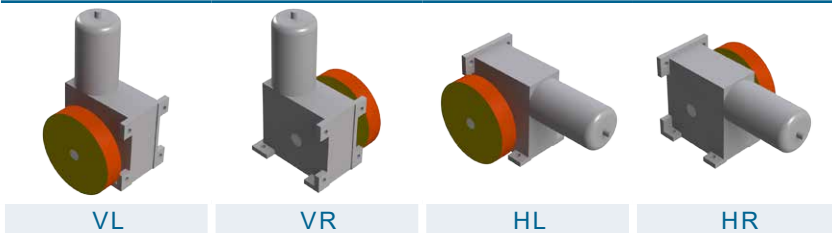

載重 Duty Load (kg)	速度 Speed (m/min)	掛比 Roping	減速比 Ratio	主槽輪 M / Sheave			馬達 Motor		
				節徑 Dia. (PCD) (mm)	鋼索 Rope (mm)	槽距 Pitch (mm)	功率 Power (kW)	極數 Poles (P)	頻率 Frequency (Hz)
1600	60	1:1	1:41	Ø560	Ø12 X 5-7	19	18.5	4	47
2500	45	2:1	2:47	Ø560	Ø12 X 5-7	19	22	4	40
2500	30	2:1	1:41	Ø560	Ø12 X 5-7	19	18.5	4	47