

電梯主機 Traction Machine

P10-4500 ^{CE}

■產品特性 Features

主軸靜荷重 Max. Static Load:	4,500 kg
最大升降行程 Allowable Travel (m):	30M
重量約 Weight:	340 kg
馬達額定電壓 Motor Rated Voltage:	208V / 360V
馬達額定電流 Motor Rated Current:	7.5kW = 31.2A / 18A ; 9kW = 37.1A / 21.3A
馬達絕緣等級 Motor INS. Class:	F
制動器電壓 Brake Voltage:	DC 110V
編碼器 Encoder:	ø30 中空型 (Central Through Type) 1024 P/R
編碼器電壓 Encoder Voltage:	DC 7-24V

■主槽輪向選擇 M/Sheave Direction

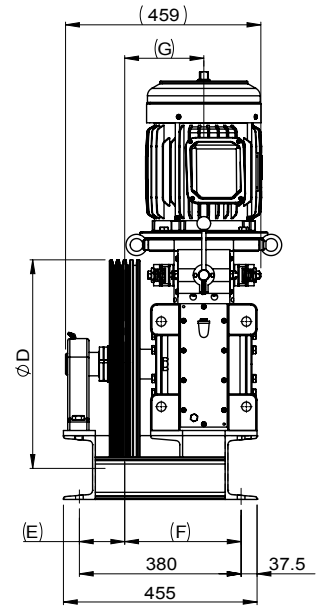
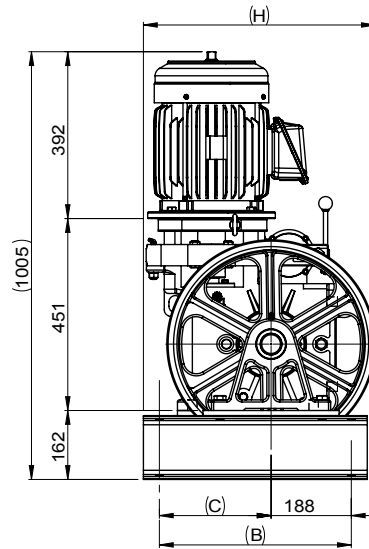
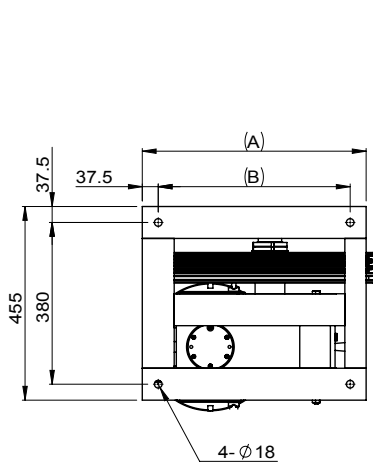
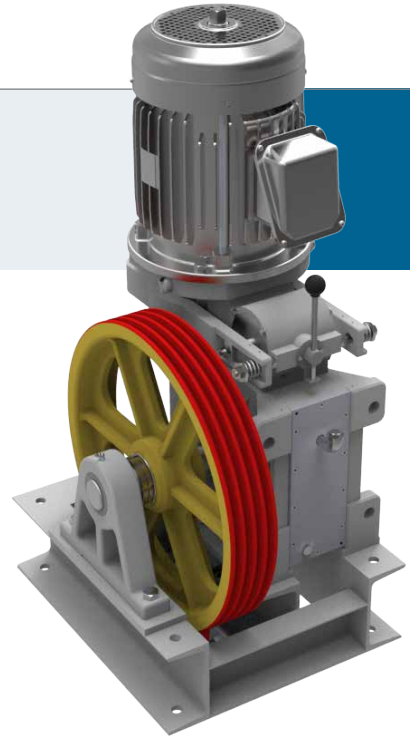
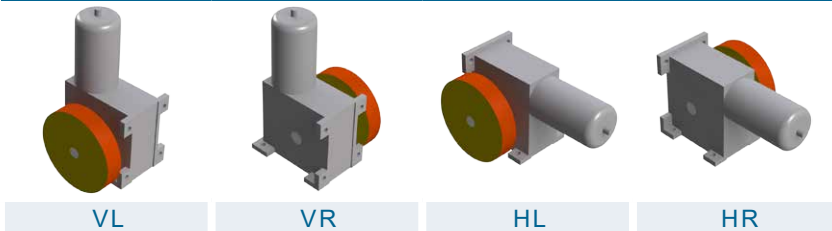

載重 Duty Load (kg)	速度 Speed (m/min)	掛比 Roping	減速比 Ratio	主槽輪 M / Sheave											馬達 Motor		
				節徑 Dia. (PCD) (mm)	鋼索 Rope (mm)	槽距 Pitch (mm)	尺寸表 Dimension								功率 Power (kW)	極數 Poles (P)	頻率 Frequency (Hz)
							A	B	C	D	E	F	G	H			
700	45	1:1	1:37	Ø485	Ø10 X 3-4 / Ø12 X 3	16 / 20	526	451	263	490	107	273	186	545	7.5	4	37
700	45	1:1	1:37	Ø510	Ø12 X 4	19	526	451	263	515	101	279	192	558	7.5	4	35
700	60	1:1	1:37	Ø485	Ø10 X 3-4 / Ø12 X 3	16 / 20	526	451	263	490	107	273	186	545	7.5	4	49
700	60	1:1	1:37	Ø510	Ø12 X 4	19	526	451	263	515	101	279	192	558	7.5	4	46
750	45	1:1	1:37	Ø510	Ø12 X 4	19	526	451	263	515	101	279	192	558	9	4	35
750	60	1:1	1:37	Ø510	Ø12 X 4	19	526	451	263	515	101	279	192	558	9	4	46
800	60	2:1	2:37	Ø485	Ø10 X 3-4 / Ø12 X 3	16 / 20	596	521	333	490	107	273	186	615	9	4	49
800	60	2:1	2:37	Ø510	Ø10 X 4 / Ø12 X 4	16 / 19	596	521	333	515	101	279	192	628	9	4	46
1150	30	2:1	1:37	Ø485	Ø10 X 3-4 / Ø12 X 3	16 / 20	596	521	333	490	107	273	186	615	9	4	49