

SHAFT-MOUNTED GEAR REDUCER SERIES

軸上型齒輪減速機系列

MODEL : SOGM

RATIO : 10, 15, 20, 25, 30

馬力 (HP) : 1HP ~ 20HP

◆ SOGM 沒有單向設計，若需要單向請選擇 SOG60#~105# 的型號。

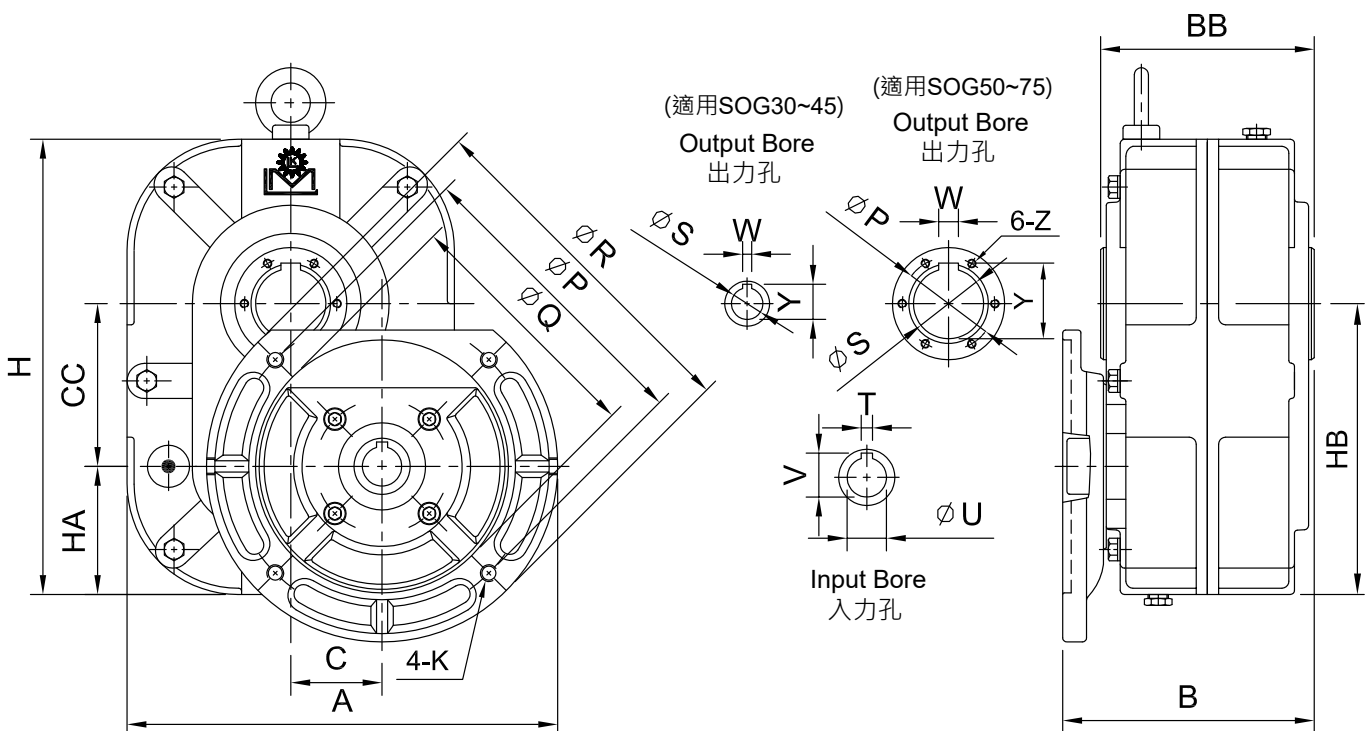

unit: mm

型號 Model	馬力 HP (4P)	減速比 Ratio	A	B	BB	C	CC	HA	HB	H	馬達盤 IEC 及入力孔 Motor Flange & Input Bore						出力孔 Output Bore					重量 Weight (kg)	油量 Oil (ℓ)	
											P	Q	R	K	V	T	U	S	W	Y	P			Z
30	1	10~30	233	135	110	49.5	81	69	150	233	165	130	200	M10	21.8	6	19	30	8	33.3	-	-	15	0.4
35	2	15~30	241	142	117	52.5	87	71	158	247	165	130	200	M10	27.3	8	24	35	10	38.3	-	-	17	0.8
40	2	10~30	241	142	117	52.5	87	71	158	247	165	130	200	M10	27.3	8	24	40	10	43.3	-	-	19	0.8
45	2 3	10~30	263	157	132	58	104	77	181	288	165	130	200	M10	27.3	8	24	45	12	48.3	-	-	30	1
			288	160	132	58	104	77	181	288	215	180	250	M12	31.3	8	28							
50	5	15~30	307	180	152	65	116	91	207	324	215	180	250	M12	31.3	8	28	50	14	53.8	66	M6	39	1.3
55	5	15~30	307	180	152	65	116	91	207	324	215	180	250	M12	31.3	8	28	55	16	59.3	69	M6	38	1.4
60	7 1/2 10	15~30	367	201	165	78.5	140	101	241	380	265	230	300	M12	41.3	10	38	60	16	64.3	80	M8	65	3
		15~30	367	201	165	78.5	140	101	241	380	265	230	300	M12	41.3	10	38	65	16	69.3	82	M8	64	3
65	7 1/2 10	15~30	367	201	165	78.5	140	101	241	380	265	230	300	M12	41.3	10	38	65	16	69.3	82	M8	64	3
75	15~20	10~30	436	243	210	84	168	137	305	480	300	250	348	M16	45.3	12	42	75	20	79.9	92	M8	131	3.9

重量不含馬達及潤滑油。 The weight does not include motor and lubricant.