

ROBONICDRIVE

諧波減速機

減速機構 Reduction Mechanism

- 通過凸輪使薄壁軸承、柔性齒輪呈橢圓狀變形。
 - 柔性齒輪與內齒輪在橢圓形長軸部分發生嚙合。
 - 固定內齒輪，使凸輪沿順時針方向旋轉 360°時，柔性齒輪會沿逆時針方向移動內齒輪與柔性齒輪的齒數差部分。
-
- Flex gear and elastic bearing take elliptic shape with the wave generator inserted.
 - Flex gear and internal gear are engaged at both ends of the long axis of the ellipse in a stable manner.
 - With the internal gear fixed, when the wave generator is rotated clockwise, the flex gear (output) rotates counterclockwise. And its rotational speed is determined by the tooth count differential between two gears.

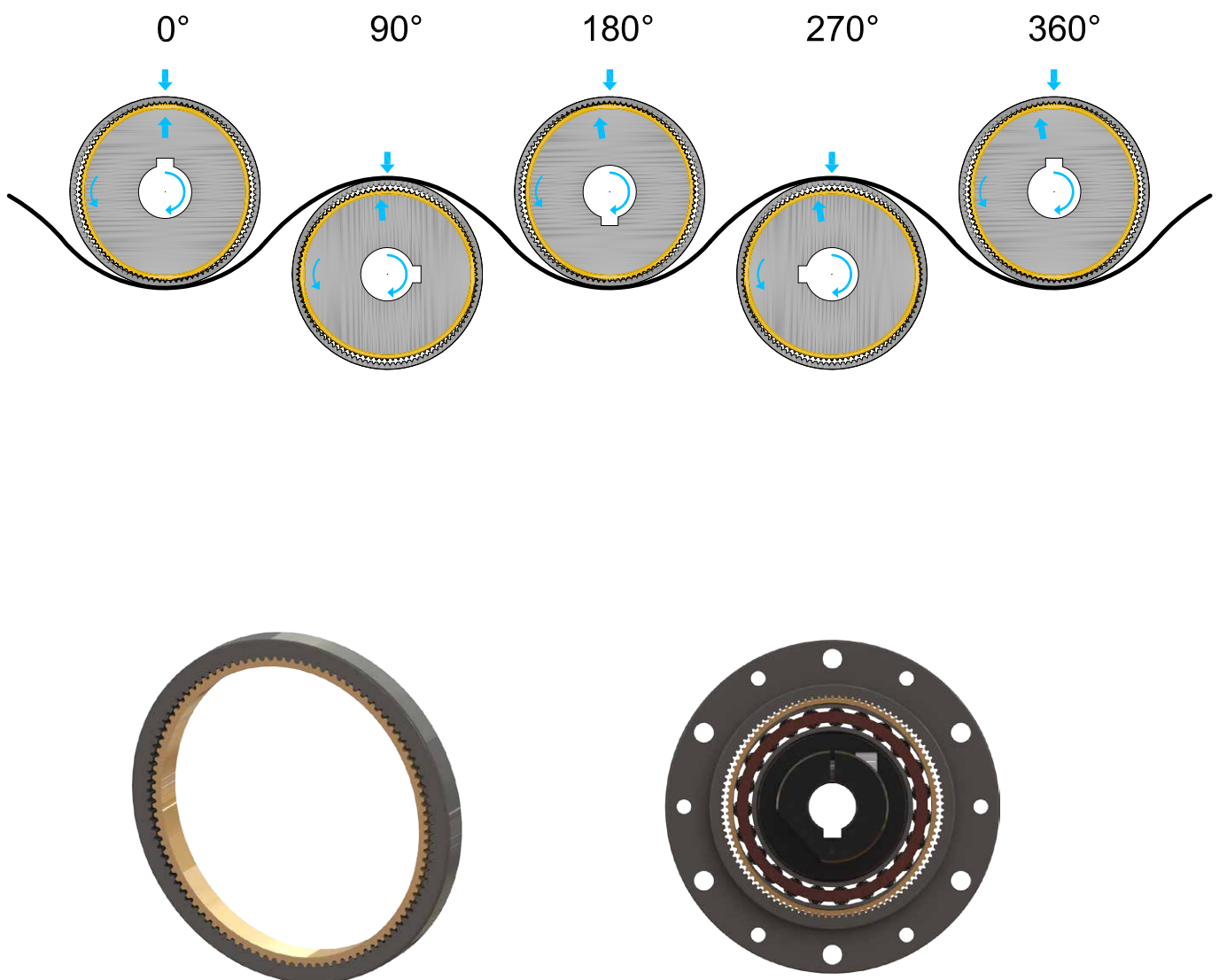

零件名稱 Parts Name

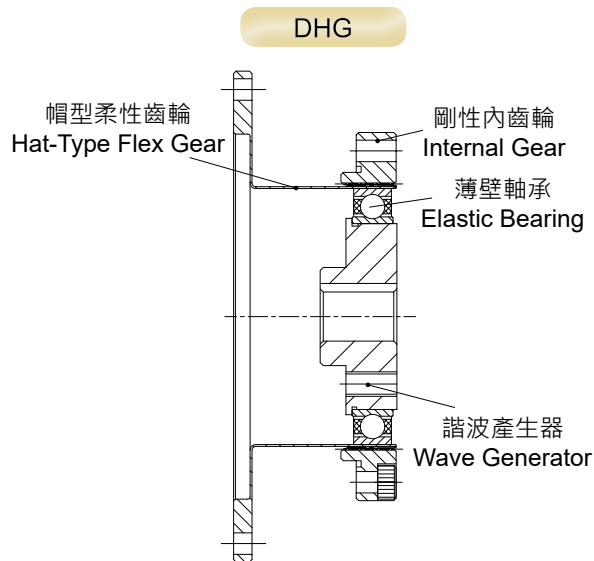
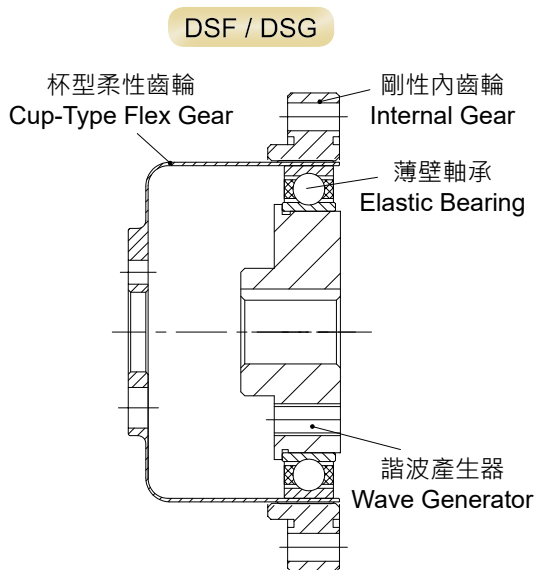

減速比 Ratio

DSF / DSG

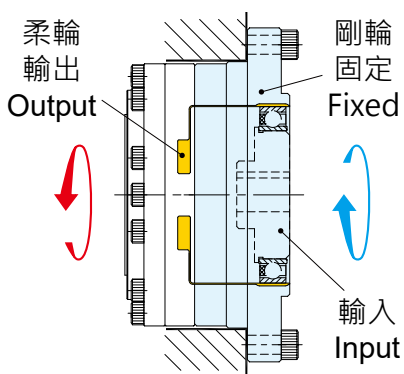
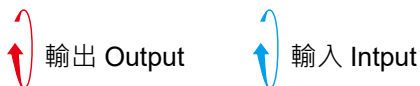

減速比由杯型柔性齒輪和剛性內齒輪來決定
The reduction ratio is determined by the flex gear and the rigid internal gear.

杯型柔性齒輪齒數 Flex Gear : Z_f
剛性內齒輪齒數 Internal Gear : Z_c

$$\text{減速比 Ratio} = \frac{-1}{R} = \frac{Z_f - Z_c}{Z_f}$$

$$\text{減速比 Ratio} = \frac{1}{R}$$

※ 輸入旋轉方向與輸出旋轉方向相反。

The input and output rotation directions are opposite.

DHG

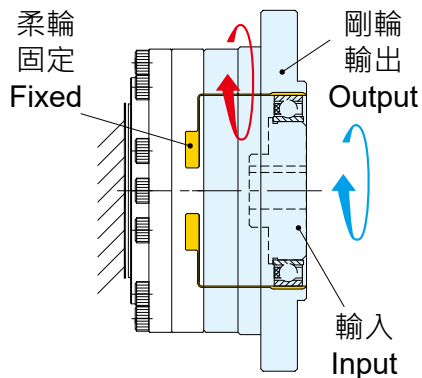
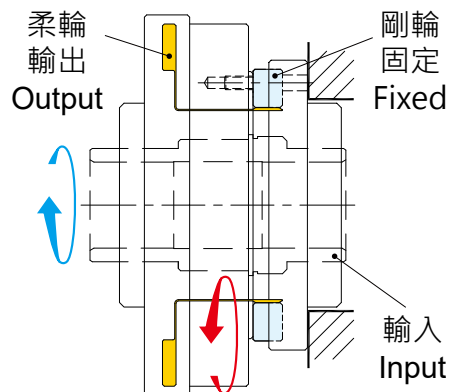

$$\text{減速比 Ratio} = \frac{1}{R+1}$$

※ 輸入旋轉方向與輸出旋轉方向相同。

The input and output rotation directions are same.

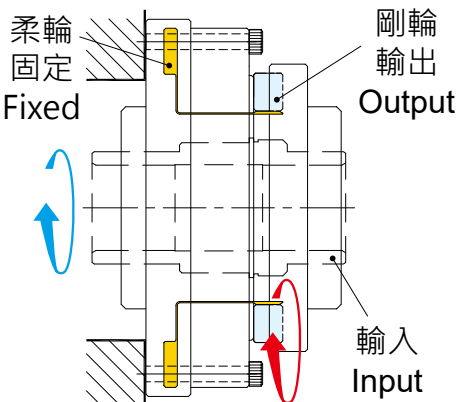

R 為減速機規格表中的減速比。R represents the "Ratio" figure in the specifications table on the catalogue.

潤滑劑 Lubricant Information

潤滑劑的使用 Lubrication

全合成潤滑油脂
Synthetic grease No.2.

unit: g

型號 Model	DSF / DSG / DHG			
	A	B	C	D
14	1	3	0.25	0.5
17	2	6	0.5	1
20	3	9	0.75	1.5
25	6	18	1.5	3
32	12	36	3	6
40	22	66	5.5	11
45	34	102	8.5	17

潤滑劑的塗抹 Grease Application

DSF 及 DHG 按照右表要求塗抹潤滑劑。
For DSF and DHG, please apply grease according to the right table.

潤滑劑的塗抹部位 Grease Application Location

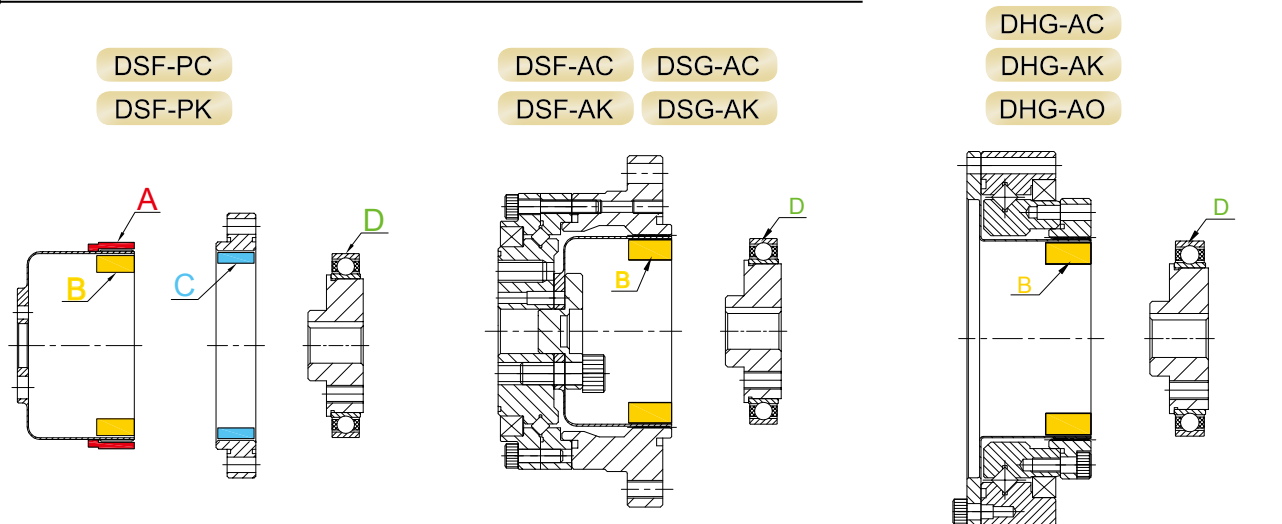

E 處填充量為空間的 50% 油量。 At location E, fill with oil to 50% of the space's capacity.

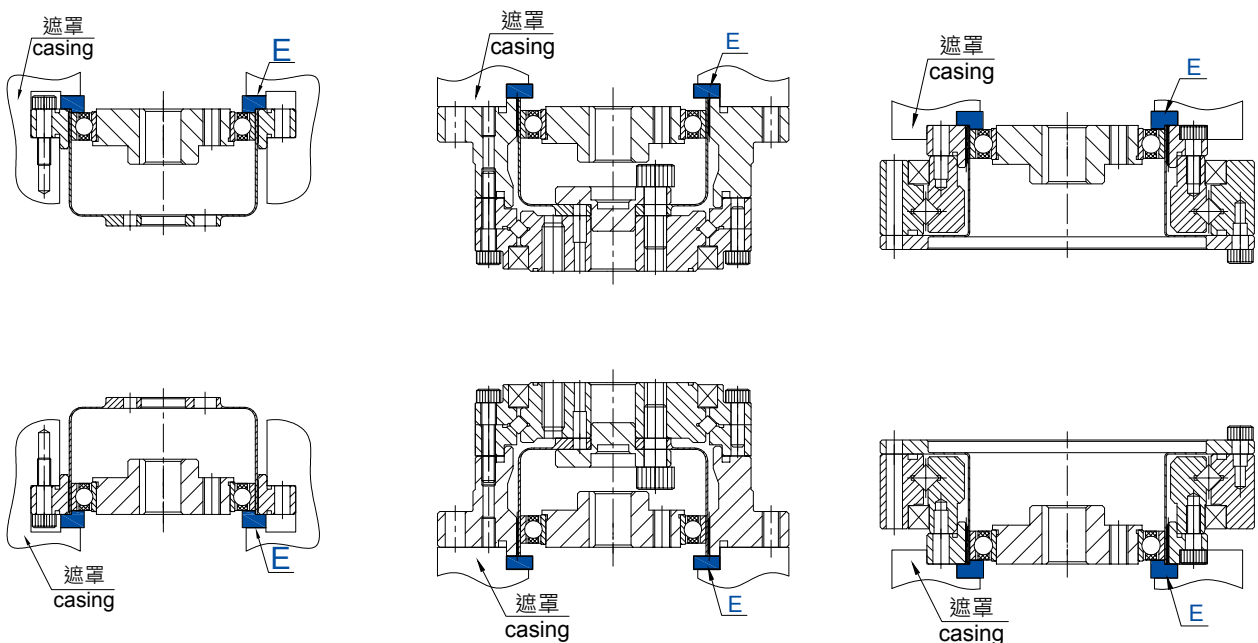

安裝精度 Attachment Fixture Requirement

DSF-PK

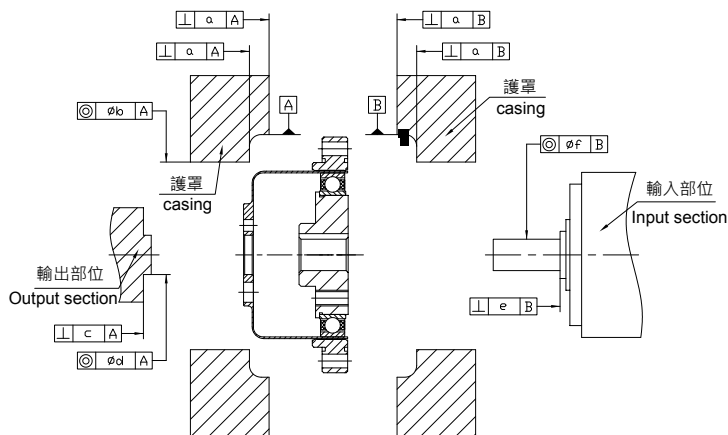

unit: mm

型號 Model	14	17	20	25	32	40
a	0.015	0.015	0.018	0.018	0.023	0.023
b	0.016	0.020	0.020	0.024	0.024	0.024
c	0.010	0.012	0.014	0.016	0.020	0.020
d	0.013	0.013	0.015	0.018	0.020	0.020
e	0.012	0.012	0.014	0.016	0.016	0.020
f	0.016	0.020	0.024	0.024	0.024	0.024

DSF-AK

DSG-AK

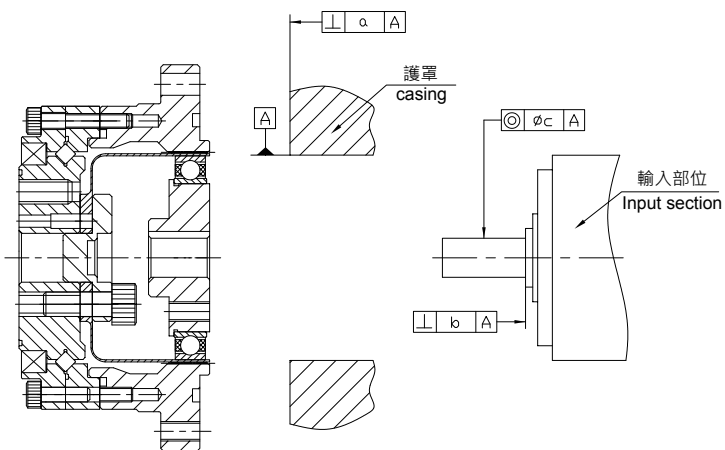

unit: mm

型號 Model	14	17	20	25	32	40
a	0.020	0.020	0.020	0.025	0.025	0.025
b	0.012	0.012	0.014	0.016	0.016	0.016
c	0.016	0.020	0.024	0.024	0.024	0.024

DHG-AK

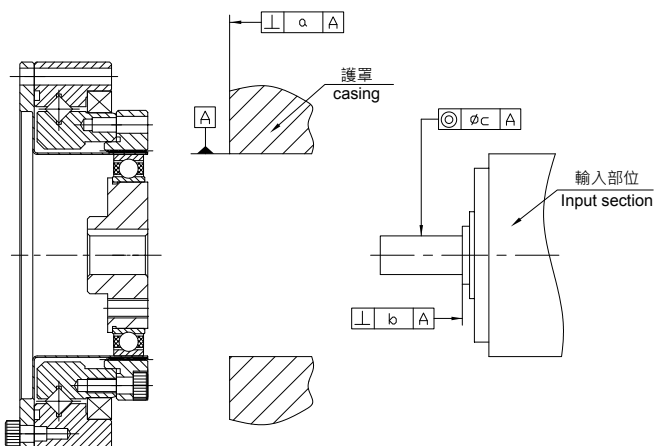

unit: mm

型號 Model	14	17	20	25	32	40	45
a	0.020	0.020	0.020	0.025	0.025	0.025	0.025
b	0.012	0.012	0.014	0.016	0.016	0.016	0.016
c	0.016	0.020	0.024	0.024	0.024	0.024	0.024

傳導力矩 Transmitting Torque

螺絲緊固力矩 Tightening Torque for Bolts

unit: Nm

螺絲 Bolts	M3	M4	M5	M6	M8	M10
螺絲緊固力矩 Tightening Torque	1.9	4.3	8.7	15	36	71

推建議螺絲：強度區分 12.9 以上

Recommended bolt : Strength rating above 12.9

傳導力矩 Bolt Specifications and Transmitting Torque

DSF-AC、DSG-AC、DSF-AK、DSG-AK (組合式 Unit Type)

安裝輸出法蘭 Output flange Attachment

型號 Model	Unit	14	17	20	25	32	40
螺絲 Bolt		M4	M5	M6	M8	M10	M10
螺絲個數 Bolt Count		6	6	8	8	8	8
安裝 PCD Bolt PCD	mm	23	27	32	42	55	68
緊固力矩 Tightening Torque	Nm	4.3	8.7	15	36	71	71
傳導力矩 Transmitting Torque	Nm	56	106	238	566	1,177	1,177

安裝內齒輪 Internal Gear Attachment (DSF)

型號 Model	Unit	14	17	20	25	32	40
螺絲 Bolt		M4	M4	M5	M5	M6	M8
螺絲個數 Bolt Count		6	6	6	8	12	8
安裝 PCD Bolt PCD	mm	65	71	82	96	125	144
緊固力矩 Tightening Torque	Nm	4.3	4.3	8.7	8.7	15	36
傳導力矩 Transmitting Torque	Nm	140	148	276	435	1,213	1,695

安裝內齒輪 Internal Gear Attachment (DSG)

型號 Model	Unit	14	17	20	25	32	40
螺絲 Bolt		M4	M4	M5	M5	M6	M8
螺絲個數 Bolt Count		8	8	8	10	12	10
安裝 PCD Bolt PCD	mm	65	71	82	96	125	144
緊固力矩 Tightening Torque	Nm	4.3	4.3	8.7	8.7	15	36
傳導力矩 Transmitting Torque	Nm	180	194	361	532	1,213	2,080

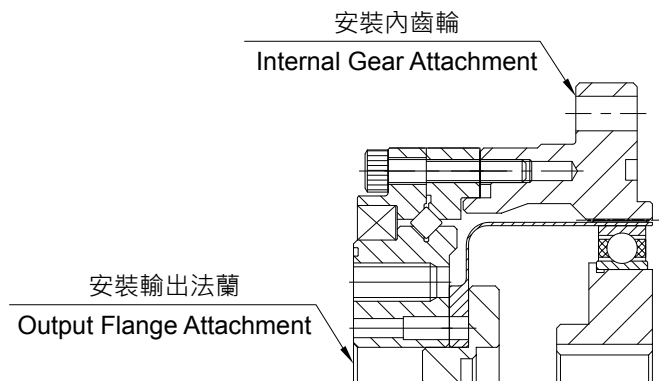

傳導力矩 Bolt Specifications and Transmitting Torque

DSF-PC、DSF-PK (組件式 Component Type)

安裝杯型柔性齒輪 Cup-Type Flex Gear Attachment

型號 Model	Unit	14	17	20	25	32	40
螺絲 Bolt		M4	M5	M5	M6	M8	M10
螺絲個數 Bolt Count		6	6	8	8	8	8
安裝 PCD Bolt PCD	mm	17	19	24	30	40	50
緊固力矩 Tightening Torque	Nm	4.3	8.7	8.7	15	36	71
傳導力矩 Transmitting Torque	Nm	41	75	126	223	539	910

安裝內齒輪 Internal Gear Attachment

型號 Model	Unit	14	17	20	25	32	40
螺絲 Bolt		M3	M3	M3	M4	M5	M6
螺絲個數 Bolt Count		12	20	16	16	16	16
安裝 PCD Bolt PCD	mm	44	54	62	77	100	122
緊固力矩 Tightening Torque	Nm	1.9	1.9	1.9	4.3	8.7	15
傳導力矩 Transmitting Torque	Nm	82	200	230	485	1,048	1,800

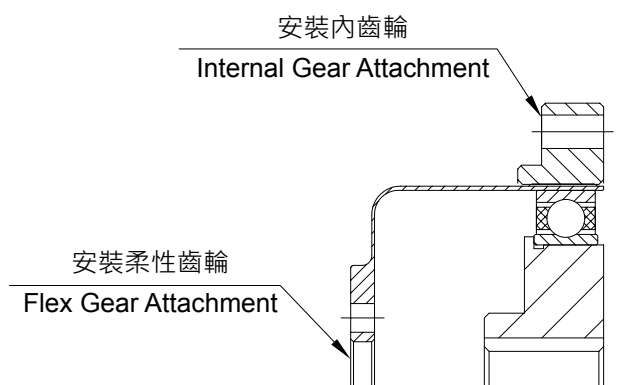

銷子孔的追加 Reinforcement

柔性齒輪安裝的傳導力矩未滿足要求時，請同時使用銷子。
銷子孔可根據需求追加。

Pins can be added if the transmittable torque at the flex gear interface is not sufficient.
As an option, holes can be added.

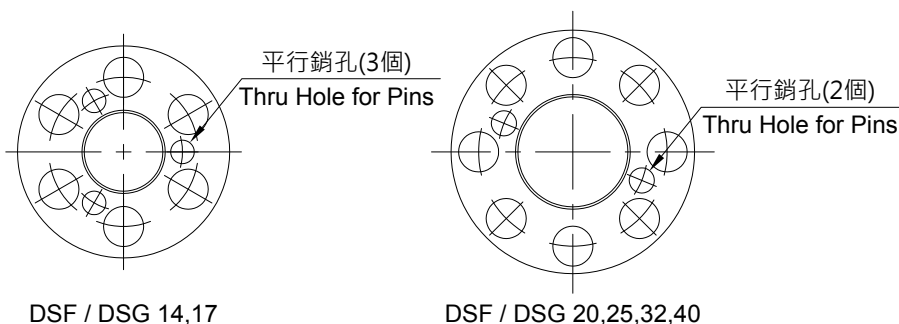

傳導力矩 Bolt Specifications and Transmitting Torque

DHG

安裝帽型柔性齒輪 Hat-Type Flex Gear Attachment

型號 Model	Unit	14	17	20	25	32	40	45
螺絲 Bolt		M3	M3	M3	M4	M5	M6	M6
螺絲個數 Bolt Count		8	12	12	12	12	12	18
安裝 PCD Bolt PCD	mm	64	74	84	102	132	158	180
緊固力矩 Tightening Torque	Nm	1.9	1.9	1.9	4.3	8.7	15	15
傳導力矩 Transmitting Torque	Nm	119	206	234	495	1,037	1,392	2,088

安裝內齒輪 Internal Gear Attachment

型號 Model	Unit	14	17	20	25	32	40	45
螺絲 Bolt		M3	M3	M3	M4	M5	M6	M8
螺絲個數 Bolt Count		8	16	16	16	16	16	12
安裝 PCD Bolt PCD	mm	44	54	62	77	100	122	140
緊固力矩 Tightening Torque	Nm	1.9	1.9	1.9	4.3	8.7	15	36
傳導力矩 Transmitting Torque	Nm	82	200	230	485	1,048	1,258	2,680

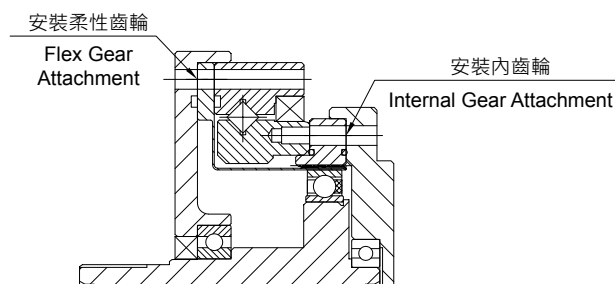
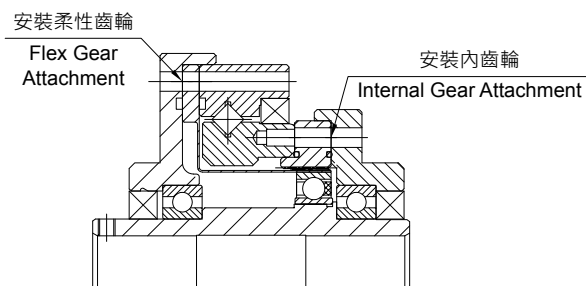
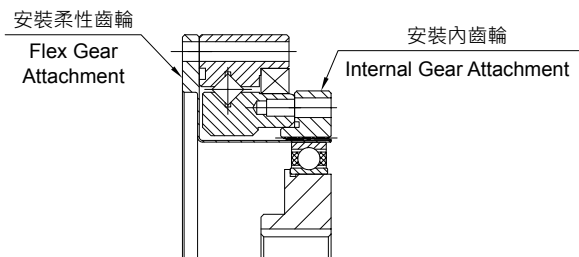

輸入部位構造 Input Section Structure

輸入部位構造 Input Section Structure

輸入部位構造分為鍵槽型與迫緊型，因輸入孔徑等差異而不同。
 There are two types of input section structure, keyway and collet + keyway.

鍵槽型
Keyway Type

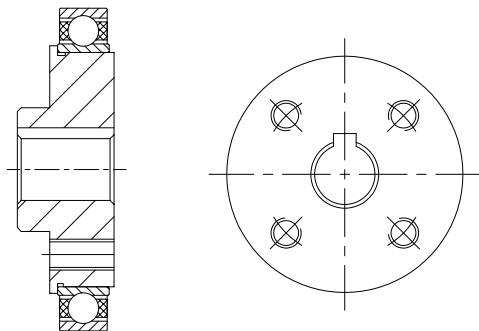

迫緊型
Collet + Keyway

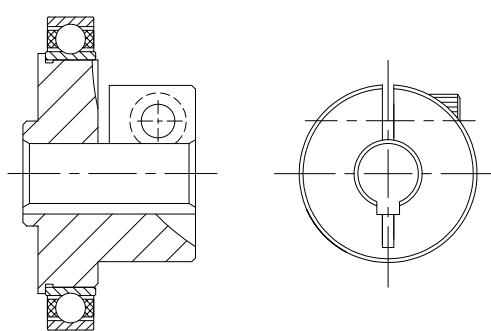

入力孔徑尺寸 Input Hole Diameter

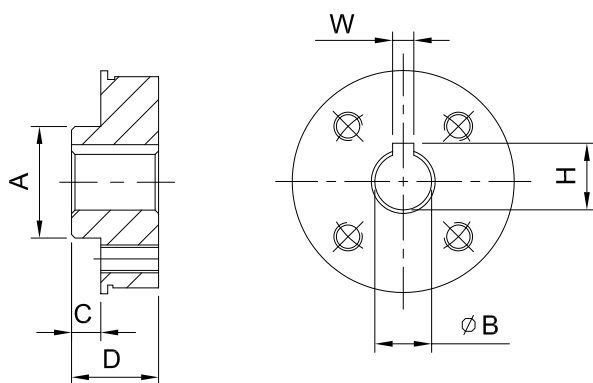

入力鍵槽尺寸 Input Bore Dimension

unit: mm

型號 Model	14	17	20	25	32	40	45
入力孔徑 Input Bore B	6、8	8	8、14	11、14	14、19	19、24	19、24
鍵槽寬 W	2、3	3	3、5	4、5	5、6	6、8	6、8
鍵高 H	7、9.4	9.4	9.4、16.3	12.7、16.3	16.3、21.8	21.8、27.3	21.8、27.3
螺絲	2-M4	2-M4	4-M4	4-M5	4-M5	4-M5、4-M6	4-M6
安裝 PCD	18	22	25	32	36	50	50
A	14	16	21	24	30	36	36
C	2.3	4.2	4.3	6	5	7	5
D	10	12.5	13.5	14.5	16	20	20

馬達安裝方法 Motor Mounting Instructions

安裝方式 Installation Method 1

- 步驟 1：將法蘭安裝至馬達上
 步驟 2：將諧波產生器安裝至馬達軸上
 步驟 3：安裝至組合型產品元件
 step 1: Attach the flange on to the motor.
 step 2: Attach the wave generator on to the motor shaft.
 step 3: Attach the unit.

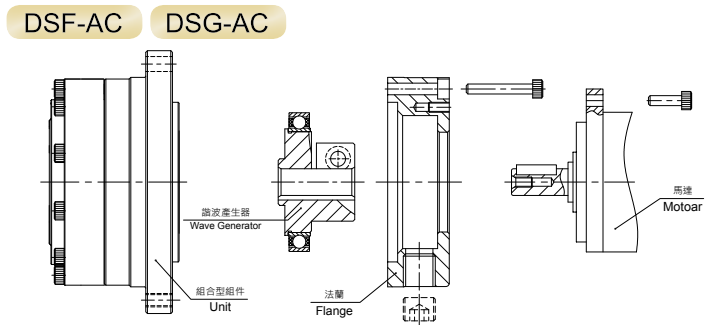
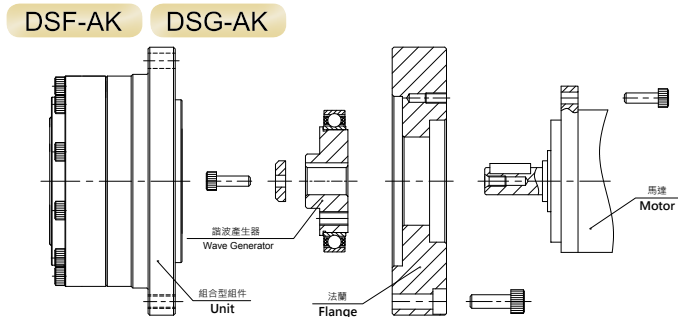

安裝方式 Installation Method 2

- 步驟 1：將諧波產生器安裝至馬達軸上
 步驟 2：將法蘭安裝至馬達上
 步驟 3：安裝至組合型產品元件
 step 1: Attach the wave generator on to the motor shaft.
 step 2: Attach the flange on to the motor.
 step 3: Attach the unit.

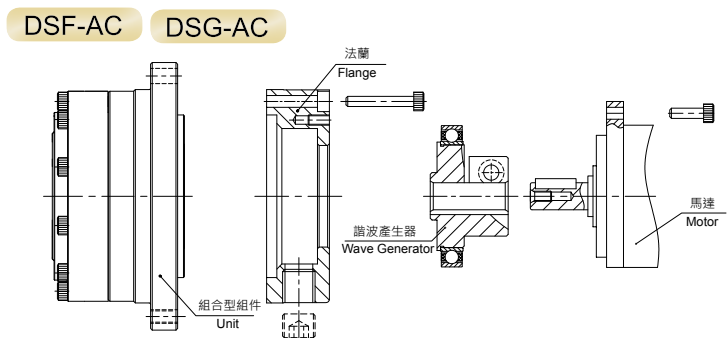
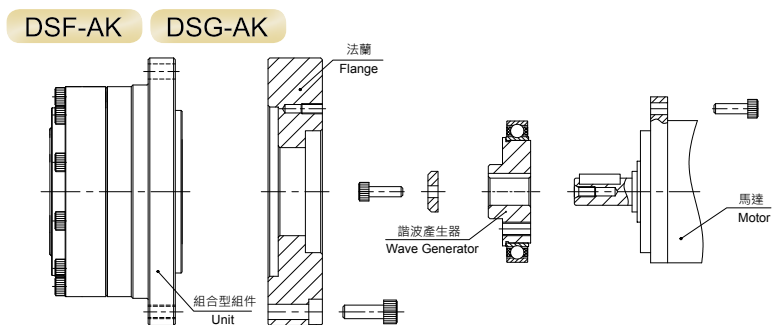

安裝操作時的注意事項 Caution during installation

- 組裝各零部件時，不可過度用力頂壓。
- 注意不可傾斜插入諧波產生器。
- Do not use excessive force while mating parts.
- Please watch for tilting during input section assembly wave generator.

注意事項 Installation and Assembly Instructions

入力軸 / 出力軸的支撐 (DSF / DSG) Shaft Installation Instruction

入力軸 / 出力軸請採用承受作用於軸部的徑向負荷 / 軸向負荷的支撐構造。(下圖為參考實例)
Please design the support structure for input shaft and output shaft so that both radial and axial loads are supported. (Diagram below shows an example)

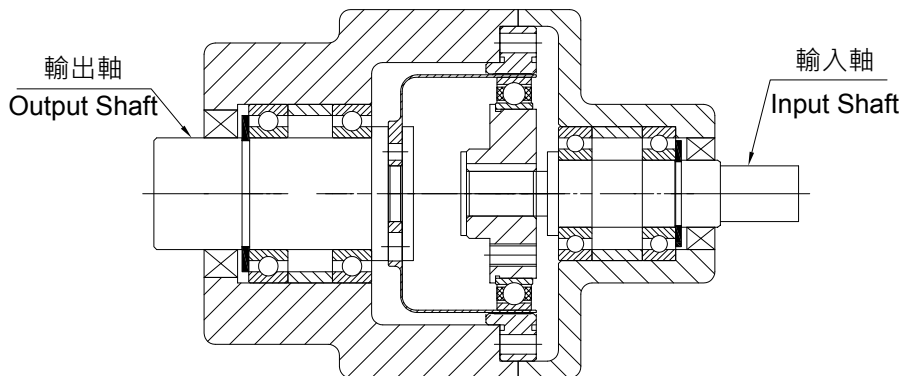

安裝方法 (DSF / DSG) Attachment Flang Requirement

安裝與杯型柔性齒輪相連接的法蘭時，為了防止造成杯型柔性齒輪破損，請保證下表所示尺寸。

For the attachment flange that comes in contact with cup-type flex gear, please build the corner radius according to the table below, in order to prevent damage.

unit: mm

型號 Model	14	17	20	25	32	40
R	0.5	0.5	0.5	0.5	0.5	0.5
D	23	26	31	38	50	65

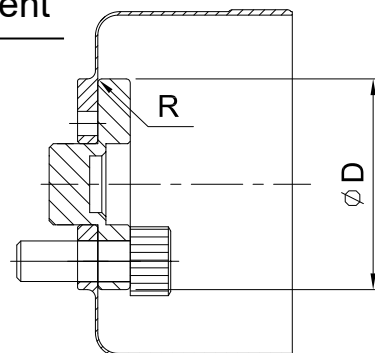

電機安裝用法蘭尺寸 (DSF / DSG)

Size Requirement of the Flange for Motor Attachment

將電機安裝至組合型元件產品時，需要安裝專用法蘭。
電機安裝專用法蘭尺寸請按照下表所示要求執行。

An attachment flange is required in order to attach a unit type to the motor. The table below shows the dimension requirement for the flange.

unit: mm

型號 Model	14	17	20	25	32	40
B	56	63	72	86	113	127
T	38H7	48H7	56H7	67H7	90H7	110H7
t	3	3	3.5	4	4	5
a	0.03	0.04	0.04	0.04	0.04	0.04
b	0.03	0.04	0.04	0.04	0.04	0.04

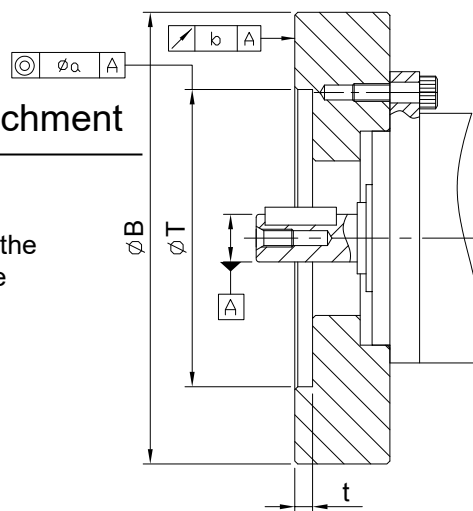

壽命 Service Life

波產生器的壽命 Service Life of the Wave Generator

減速機的使用壽命，由波產生器軸承的壽命決定。和一般滾珠軸承相同，由轉速與負載轉矩計算求出。
 The service life of reducer is determined by the service of the wave generator bearing, and you can calculate this by the rotational speed and the load torque just as with a general ball bearing.

壽命時間 Service Life

機型 Type	DSF、DSG、DHG
L_{10} (10% 受損機率 Damage Probability)	7,000 horus
L_{50} (平均壽命 Average Service Life)	35,000 horus

※ 額定表記載之額定轉速、額定轉矩下的運轉壽命。

Service is based on the rated rotational speed and rated torque from the ratings.

依據實際運轉條件的壽命時間 (Lh) 公式

Calculation formula for service Life (Lh) by actual operation condition

$$Lh = L_n \cdot \left(\frac{Tr}{Tav}\right)^3 \left(\frac{Nr}{Nav}\right)$$

- L_n : L_{10} 或 L_{50} 時的壽命時間 Service Life of L_{10} or L_{50}
- Tr : 額定轉矩 Rated Torque
- Nr : 額定轉速 Rated Rotational Speed
- Tav : 輸出端的平均負載轉矩 Average Load Torque on the Output Side
- Nav : 平均輸入轉速 Average Input Rotational Speed

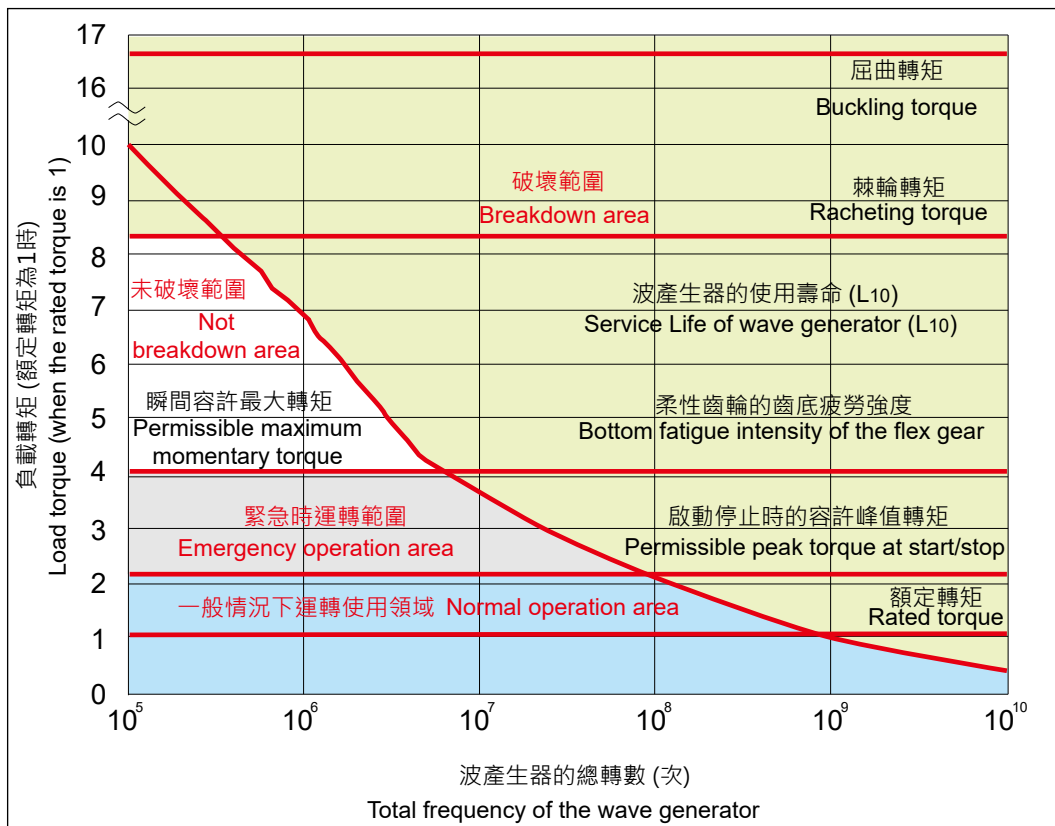

請維持在「一般時運轉使用區域」中使用。若超出「一般時運轉使用區域」使用範圍，將加速減速機的損壞。
 上述圖表未考慮齒面磨耗等潤滑壽命，請以上述圖表作為參考值。

Use it within the range of "Normal operation area". Using it beyond "Emergency operation area" may result in damaging reducer earlier than usual.

Lubricant life such as for abrasion on the tooth surface is not taken into consideration in the graph described above. Use the graph above as reference values.

強度 Intensity

柔性齒輪的強度 Intensity of Flex Gear

柔性齒輪會反覆發生彈性變形，所以減速機的傳動轉矩以柔性齒輪的齒根疲勞強度為基準。額定轉矩、起動與停止時的容許峰值轉矩等數值，為柔性齒輪的齒根疲勞極限之內的數值。若施加超過起動或停止峰值轉矩的衝擊轉矩，恐將產生疲勞破壞。

為了避免產生疲勞破壞，設有衝擊轉矩的施加次數限制。但衝擊轉矩的最大值不得超過瞬間容許最大轉矩。

As flexs gear repeats elastic deformation, the transmission torque of reducer is calculated based on the fatigue strength of the bottom of the flex gear.

Values of the rated torque and permissible peak torque for start and stop are those within the fatigue limit of the bottom of the flexs gear.

If impact torque that exceeds the peak torque for start and stop is applied, it could generate fatigue fracture.

Therefore, the number of applications of impact torque is limited to prevent possible fatigue fracture.

However, the maximum value of the impact torque cannot exceed the permissible maximum momentary torque.

在波產生器承受衝擊轉矩時，柔性齒輪的彈性變形次數限制：

Restriction on the bending frequency of the flexs gear by the rotation of the wave generator while the impact torque is applied:

1.0×10^4 (次 frequency)

基於此一彈性變形次數限制，可求出衝擊轉矩施加的容許次數。

You can calculate the permissible frequency of impact torques from this restriction on the bending frequency.

計算公式 Calculation Formula

$$N = \frac{1.0 \times 10^4}{2 \times \frac{n}{60} \times t}$$

容許次數 Permissible Frequency : N 次
 衝擊轉矩的施加時間 Time that Impact Torque is Applied : t sec
 當時的波產生器轉速 Rotational Speed of the Wave Generator : n r/min

波產生器旋轉 1 圈，將使柔性齒輪產生 2 次彈性變形。

The flexs gear bends two times by one cycle of the wave generator.

屈曲轉矩 Buckling Torque

波產生器為固定狀態下，對柔性齒輪（輸出）施加過度轉矩時，將引起柔性齒輪的塑性變形，並將導致柔性齒輪中部發生屈曲，進而破壞。此時的轉矩，稱為屈曲轉矩。

When excess torque is applied to the flexs gear (output) with the wave generator fixed, the flexs gear causes elastic deformation, buckles on the body before long and will be destroyed. The torque at the time is called buckling torque.

棘輪轉矩 Ratcheting Torque

運轉中若施加過度的衝擊轉矩，可能出現柔性齒輪未破損，但剛性齒輪與柔性齒輪的嚙合瞬間脫開的情況。此一現象稱為棘輪效應，此時的轉矩稱為棘輪轉矩。

When excess impact torque is applied during operation, the engagement of the teeth between the internal gear and the flexs gear may be put momentarily out of alignment instead of damaging the flexs gear. This phenomenon is called ratcheting, and the torque is called "ratcheting torque".

齒輪嚙合偏向單側的情況 When the engagement of the teeth is out of alignment

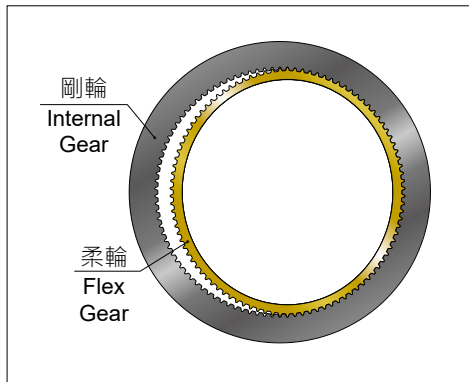

- ※ 發生棘輪效應時，無法正常嚙合，可能如圖般偏向單側。如在此狀態下運轉，將因產生振動引起彈性齒杯破損。
- ※ 一旦發生棘輪效應，齒尖將會磨耗，第二次以後的棘輪效應發生轉矩值將會降低。
- ※ When ratcheting is caused, the teeth may not be correctly engaged and become out of alignment as shown. As operating the drive in this condition will generate vibration and damage the flexspline, adequate care should be exercised.
- ※ Once ratcheting is caused, the tips of the teeth are worn and the torque value generated by ratcheting will be lowered. Pay due attention to this opint as well.

此一情況，稱為空轉。 This condition is called "dedoi-dal".

剛性 Stiffness

固定輸入側，將力矩施加至輸出側時的彈簧常數與扭曲角度。

In this context, stiffness is the output shaft twisting angle and the spring coefficient, while torque load is applied to the output shaft with input side fixed.

- K_1 力矩 $0 \sim T_1$ 的彈簧常數
Spring coefficient at $0 \sim T_1$ torque
- K_2 力矩 $T_1 \sim T_2$ 的彈簧常數
Spring coefficient at $T_1 \sim T_2$ torque
- K_3 力矩 $T_2 \sim$ 的彈簧常數
Spring coefficient at $T_2 \sim$ torque

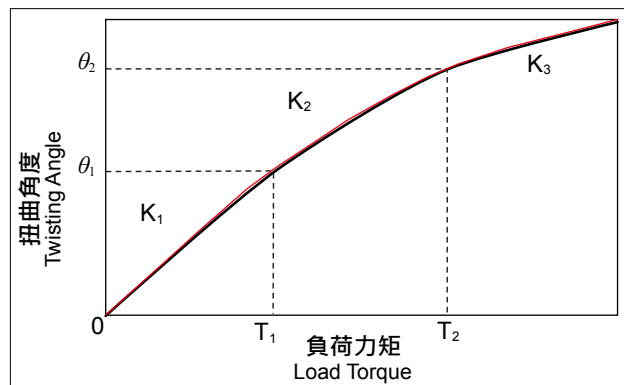

減速比 Ratio	代號 Code	單位 Unit	14	17	20	25	32	40	45
-	T_1	Nm	2	4	8	16	30	62	76
-	T_2	Nm	6.8	12	24	50	110	210	280
50	K_1	X 10^4 Nm/rad	0.28	0.70	1.20	2.80	5.60	11.00	15.00
	K_2	X 10^4 Nm/rad	0.45	0.86	1.80	3.40	7.20	14.00	20.00
	K_3	X 10^4 Nm/rad	0.60	1.70	2.60	4.20	8.50	18.00	24.00
	θ_1	arcmin	2.45	1.96	2.29	1.72	1.84	1.93	1.74
	θ_2	arcmin	5.19	4.79	4.58	5.05	5.25	4.51	4.80
80 100 120	K_1	X 10^4 Nm/rad	0.46	0.92	1.50	3.40	7.00	12.00	17.00
	K_2	X 10^4 Nm/rad	0.65	1.20	1.80	3.80	8.20	18.00	23.00
	K_3	X 10^4 Nm/rad	0.70	1.80	2.60	4.60	9.70	22.00	29.00
	θ_1	arcmin	1.50	1.50	1.80	1.62	1.47	1.78	1.54
	θ_2	arcmin	3.59	3.43	4.58	4.52	4.60	4.00	4.18

※ 表中數值為平均值。 Average value shown in the table.

入力軸容許負荷 Maximum Load at Input Shaft

軸承規格 Bearing Specification

unit: N

系列 Series	型號 Model	軸承 A Bearing A		軸承 B Bearing B		a	b
		基本動態額負荷 Basic Dynamic Load Rating	基本靜態額負荷 Basic Static Load Rating	基本動態額負荷 Basic Dynamic Load Rating	基本靜態額負荷 Basic Static Load Rating		
		Co	Cor	Co	Cor		
		N	N	N	N		
						mm	mm
DHG-O	14	5,000	2,450	5,000	2,450	16	27.5
	17	5,400	2,950	5,400	2,950	16.0	31.0
	20	5,650	3,400	5,650	3,400	14.5	27.5
	25	6,150	4,200	6,150	4,200	15.5	31
	32	17,700	10,900	8,200	6,100	20.0	36.0
	40	25,200	17,300	14,300	10,600	24.5	43.5
	45	21,700	16,100	14,900	11,500	24.5	46.5
DHG-S	14	5,700	1,950	2,800	910	23	23
	17	6,400	2,400	2,800	910	25.0	25.5
	20	7,000	2,850	2,800	910	30.5	27.5
	25	7,500	3,250	5,400	2,250	36.0	30.5
	32	11,700	5,050	7,000	2,850	39.0	37.0
	40	17,500	7,850	11,700	5,050	46.5	45.0
	45	17,500	7,850	12,600	5,850	46.5	50.5

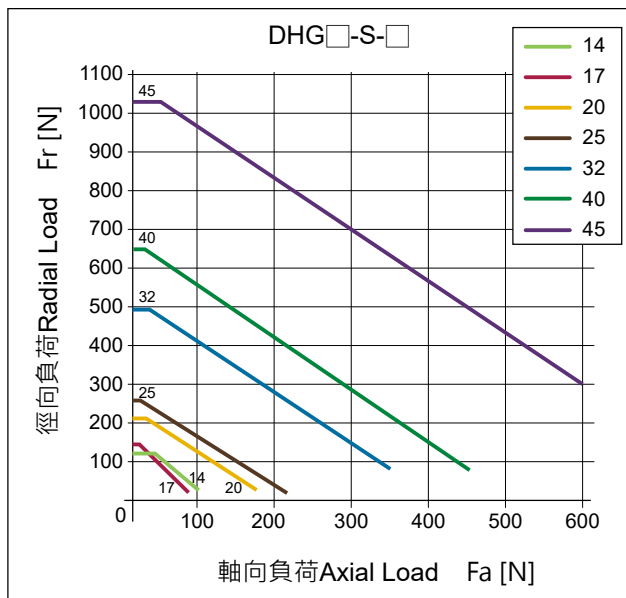
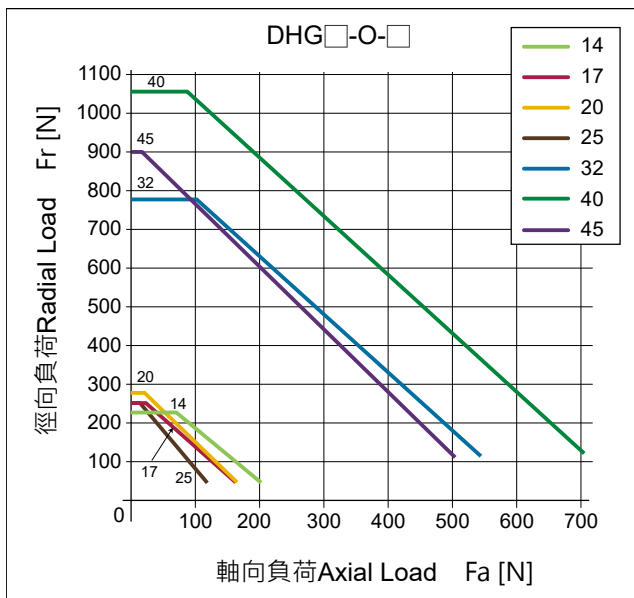
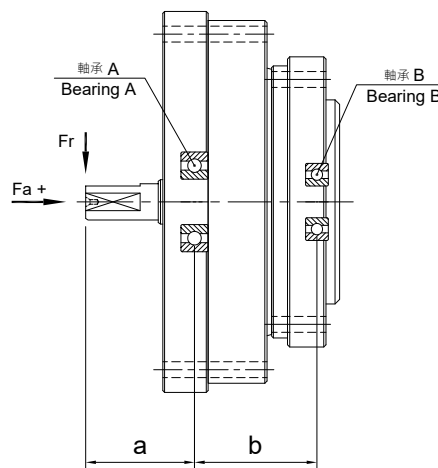
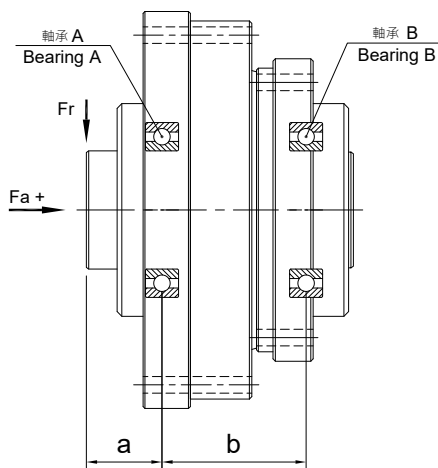

薄壁軸承壽命計算 Life Span for the Elastic Bearing

運轉類型 Operation Cycle Example

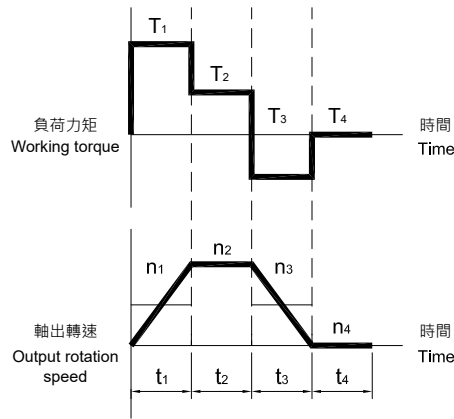

①平均輸出力矩 / 最大輸出力矩的計算 Calculation Formula for Output Torque

平均輸出力矩 Average Output Torque	Tao	Nm	$T_{ao} = \sqrt[3]{\frac{n_1 \cdot t_1 \cdot T_1 ^3 + n_2 \cdot t_2 \cdot T_2 ^3 + \dots + n_n \cdot t_n \cdot T_n ^3}{n_1 \cdot t_1 + n_2 \cdot t_2 + \dots + n_n \cdot t_n}}$
最大輸出力矩 Peak Output Torque Value	Tmo	Nm	$T_{mo} = T_1, T_2, \dots, T_n$ 的最大值 Largest Among

※ 請確認最大輸出力矩為容許最大輸出值以下。

Please make sure the peak output torque is below the maximum output torque in the specification table.

②平均輸入轉速 / 最高輸入轉速的計算 Calculation Formula for Input Speed

平均輸出轉速 Average Output Rotation Speed	nao	r/min	$n_{ao} = \frac{n_1 \cdot t_1 + n_2 \cdot t_2 + \dots + n_n \cdot t_n}{t_1 + t_2 + \dots + t_n}$
最高輸出轉速 Peak Output Rotation Speed	nmo	r/min	$n_{mo} = n_1, n_2, \dots, n_n$ 的最大值 Largest Among
平均輸入轉速 Average Input Speed	nai	r/min	$n_{ai} = n_{ao} \cdot R$ (R= 減速比 Ratio)
最高輸入轉速 Peak Input speed Value	nmi	r/min	$n_{mi} = n_{mo} \cdot R$ (R= 減速比 Ratio)

※ 請確認最高輸入轉速為容許最高輸入轉速值以下。

Please make sure the peak input speed value is below the maximum input speed in the specification table.

③壽命時間的計算 Calculation Formula for Life Span

薄壁軸承壽命時間 Part Life Span for the Elastic Bearing	Lhe	h	$L_{he} = 7000 \cdot \left(\frac{T_{ar}}{T_{ao}}\right)^3 \cdot \left(\frac{n_{ar}}{n_{ai}}\right)$
額定力矩 Rating Torque	Tar	Nm	性能表中所記容許平均力矩 Nominal Output Torque in the Specification Table
額定輸入轉速 Rating Input Rotation Speed	nai	r/min	2000 r/min

主軸承 Main Bearing

主軸承規格 (交叉圓柱滾子軸承)

Main Bearing Specification (Crossed Roller Bearing)

機型 Type	型號 Model	滾軸節圓直徑 Pitch Circle Diameter of the Bearing Rollers	偏移量 Offset	基本動態額定負荷 Basic Dynamic Load Rating	基本靜態額定負荷 Basic Static Load Rating	容許力矩荷重 Allowable Moment	力矩剛性 Moment Rigidity
		Dm	L	Cr	Cor	Mc	Km
		mm	mm	N	N	kgfm	kgfm/arcmin
DSF DSG	14	32.8	9.5	4,800	7,200	4.2	1.3
	17	38.5	9.5	5,500	8,250	6.5	2.3
	20	46.2	9.5	7,050	10,580	9.3	3.8
	25	57.6	11.5	9,900	14,800	16	7.2
	32	76.8	12.5	12,900	19,300	32	16
	40	92.0	14.5	16,800	25,200	46	27
DHG-AC DHG-AK	14	53.8	10.3	6,000	8,800	7.6	2.5
	17	61.5	11.9	10,700	16,800	12.6	4.6
	20	70.4	12.0	15,000	22,700	19.1	7.5
	25	84.5	14.1	22,400	37,000	26.3	11.6
	32	108.0	15.9	39,400	65,100	59.1	29.6
	40	135.0	19.0	44,600	74,000	86.6	53.2
DHG-O DHG-S	14	53.8	21.8	6,000	8,800	7.6	2.5
	17	61.5	23.9	10,700	16,800	12.6	4.6
	20	70.4	25.5	15,000	22,700	19.1	7.5
	25	84.5	29.6	22,400	37,000	26.3	11.6
	32	108.0	36.4	39,400	65,100	59.1	29.6
	40	135.0	44.5	44,600	74,000	86.6	53.2
	45	154.0	47.5	65,400	98,000	115	76.3

主軸承壽命計算 Part Life Span for the Main Bearing

運轉類型 Operation Cycle Example

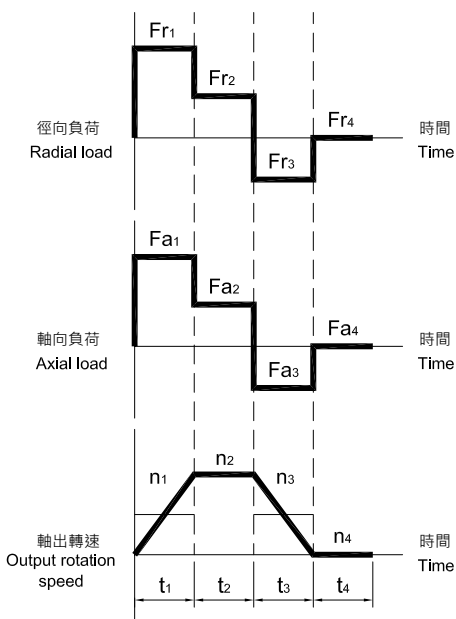

外部負荷 External Load

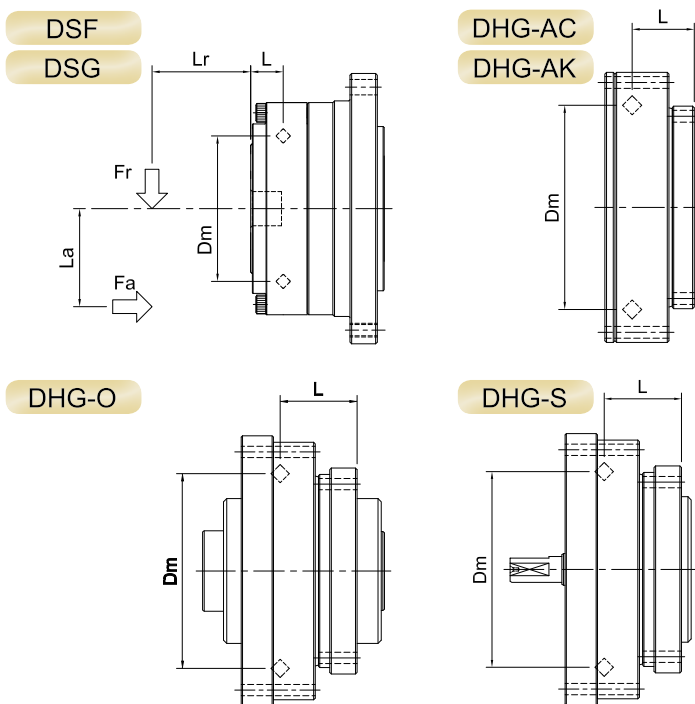

①最大負荷慣量的計算 Calculation Formula for the Largest Working Moment

最大負荷慣量 Peak Working Moment	Mm	Nm	$Mm = Frm \cdot (Lr + L) + Fam \cdot La$
最大徑向負荷 Peak Radial Load	Frm	N	$Frm = Fr_1, Fr_2, \dots, Fr_n$ 的最大值 Largest Among
最大軸向負荷 Peak Axial Load	Fam	N	$Fam = Fa_1, Fa_2, \dots, Fa_n$ 的最大值 Largest Among

※ 請確認最大負荷慣量為容許慣量值以下。

Please make sure the peak working moment is below the maximum allowable moment.

②平均徑向負荷 / 軸向負荷 / 平均輸出轉速 / 平均負荷慣量的計算

Calculation Formula for Average Radial Load, Axial Load, Average Output Rotation Speed, Average Working Moment.

平均徑向負荷 Average Radial Load	Fra	N	$Fra = \sqrt[10]{\frac{n_1 \cdot t_1 \cdot Fr_1 ^{\frac{10}{3}} + n_2 \cdot t_2 \cdot Fr_2 ^{\frac{10}{3}} + \dots + n_n \cdot t_n \cdot Fr_n ^{\frac{10}{3}}}{n_1 \cdot t_1 + n_2 \cdot t_2 + \dots + n_n \cdot t_n}}$
平均軸向負荷 Average Axial Load	Faa	N	$Faa = \sqrt[10]{\frac{n_1 \cdot t_1 \cdot Fa_1 ^{\frac{10}{3}} + n_2 \cdot t_2 \cdot Fa_2 ^{\frac{10}{3}} + \dots + n_n \cdot t_n \cdot Fa_n ^{\frac{10}{3}}}{n_1 \cdot t_1 + n_2 \cdot t_2 + \dots + n_n \cdot t_n}}$
平均輸出轉速 Average Output Rotation Speed	nao	r/min	$nao = \frac{n_1 \cdot t_1 + n_2 \cdot t_2 + \dots + n_n \cdot t_n}{t_1 + t_2 + \dots + t_n}$
平均負荷慣量 Average Working Moment	Ma	Nm	$Ma = Fra \cdot (Lr + L) + Faa \cdot La$

③負荷系數 / 動態等價徑向負荷的計算

Calculation Formula for the Loading Factor, Equivalent Radial Load

負荷系數 Average Working Moment	Xc, Yc	-	$\frac{Faa}{Fra + 2Ma / Dm} \leq 1.5$ 時, $Xc = 1.0, Yc = 0.45$
			$\frac{Faa}{Fra + 2Ma / Dm} > 1.5$ 時, $Xc = 0.67, Yc = 0.67$
動態等價徑向負荷 Equivalent Radial Load	Pc	N	$Pc = Xc \cdot (Fra + 2Ma / Dm) + Yc \cdot Faa$

④主軸承壽命時間的計算 Life Span for the Main Bearing

主軸承壽命時間 Life Span for the Main Bearing	Lhc	h	$Lhc = \frac{10^6}{60 \cdot nao} \cdot \left(\frac{C}{fw \cdot Pc} \right)^{\frac{10}{3}}$
衝擊系數 Impact Factor	fw	-	1.0 : 未伴隨衝擊時 No Shock
			1.2 : 伴隨些許衝擊時 With Some Shock
			1.5 : 伴隨振動衝擊時 With Shock and Vibration

特性數據 Characteristics Data

unit: arc min

角度傳達精度

Transmission Angular Accuracy

在無負荷條件下使入力軸旋轉時，理論上輸出旋轉角度與實際輸出旋轉角度的差值。

It is the difference between the measured output rotation angle and the theoretical angle, while input shaft is rotated with no load.

機型 Type	減速比 Ratio	14	17	20	25	32	40	45
DSF DSG	50	2.0	2.0	1.5	1.0	1.0	1.0	-
	80	1.5	1.5	1.0	1.0	1.0	1.0	-
	100	1.5	1.5	1.0	1.0	1.0	1.0	-
	120	-	1.5	1.0	1.0	1.0	1.0	-
DHG	50	2.0	2.0	1.5	1.0	1.0	1.0	1.0
	80	1.5	1.5	1.0	1.0	1.0	1.0	1.0
	100	1.5	1.5	1.0	1.0	1.0	1.0	1.0
	120	-	1.5	1.0	1.0	1.0	1.0	1.0

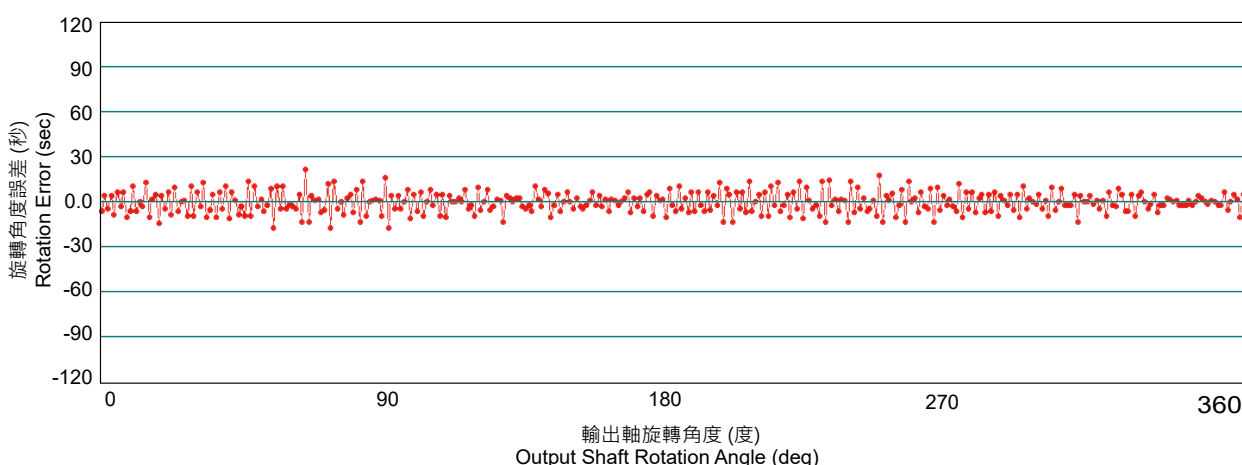

震動 On Vibration

ROBONICDRIVE 帶有的角傳動誤差成分，有時會顯現為負載端的慣性旋轉振動。

尤其是包含 ROBONICDRIVE 的振動系固有振動數與機體或負載慣性固有振動數重疊時，將形成共振狀態，ROBONICDRIVE 的角傳動誤差成分將會增幅，因此請嚴格遵守各系列的設計指南。

另外，ROBONICDRIVE 的角傳動誤差成分主要來源，是由於 ROBONICDRIVE 結構上輸入軸旋轉 1 次會出現 2 次誤差成分。因此，誤差主要成分的頻率是輸入頻率的 2 倍。

The angle transmission error elements of ROBONICDRIVE may appear as rotating vibration of the load side inertia.

Especially, when the characteristic frequency of the vibration system including ROBONICDRIVE overlaps that of the chassis or load inertia, it generates a resonant condition that amplifies angle transmission error elements of ROBONICDRIVE. Observe the design guide of each series.

Two angle transmission error elements of ROBONICDRIVE correspond to a cycle of the input shaft from the mechanical viewpoint of ROBONICDRIVE. Therefore, the frequency is double the input frequency as it is the main element of the error.

f 包含 ROBONICDRIVE 的振動系固有振動數 [Hz]

The characteristic frequency of the vibration system including ROBONICDRIVE

$$f = \frac{1}{2\pi} \sqrt{\frac{K}{J}}$$

K ROBONICDRIVE 的彈簧常數 [Nm/rad]

Spring constant of ROBONICDRIVE

J 負載慣性 [kgm²]

Load inertia

假設包含 ROBONICDRIVE 的振動系固有振動數為 $f=15\text{Hz}$ ，此時的輸入轉速 (N) 為

If the characteristic frequency of the vibration system including ROBONICDRIVE is $F=15\text{Hz}$, the input rotation speed (N) is expressed as shown below.

$$N = \frac{15}{2} \cdot 60 = 450 \text{ r/min}$$

· 且於該轉速帶 (450 r/min) 發生共振。

The resonant condition is generated in the rotating speed area (450 r/min).

滯後損失 Hysteresis Loss

unit: arcmin

輸入側固定後，將力矩施加至輸出側且 0 力矩時的扭曲角度差。

When torque load is applied at the output shaft in alternate direction repeatedly with input shaft fixed, there is residual twisting angle when torque is back to zero.

In this context, hysteresis loss is the difference in the forward and backward twisting angle.

機型 Type	減速比 Ratio	14	17	20	25	32	40	45
DSF DSG	50	2.0	2.0	2.0	2.0	2.0	2.0	-
	80	1.5	1.5	1.0	1.0	1.0	1.0	-
	100	1.5	1.5	1.0	1.0	1.0	1.0	-
	120	-	1.5	1.0	1.0	1.0	1.0	-
DHG	50	2.0	2.0	2.0	2.0	2.0	2.0	2.0
	80	1.5	1.5	1.0	1.0	1.0	1.0	1.0
	100	1.5	1.5	1.0	1.0	1.0	1.0	1.0
	120	-	1.5	1.0	1.0	1.0	1.0	1.0

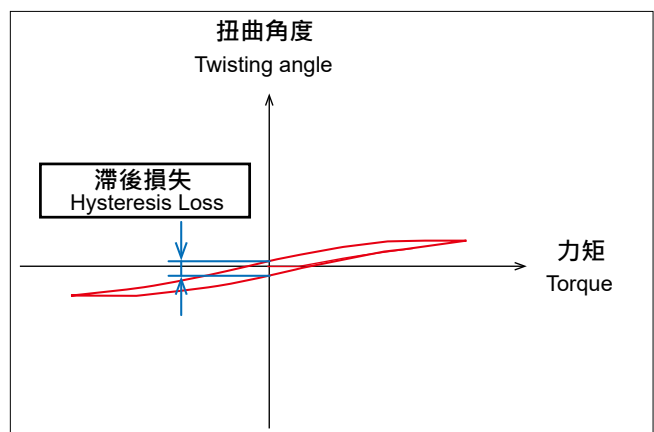

額定輸出扭矩 Nominal Output Torque

減速機輸入轉速 2,000 r/min 時，可以長時間加載的扭矩。

The indicates permissible continuous load torque when the input speed is 2,000 r/min.

起動轉矩 Starting Torque

由輸入側使其旋轉時，輸入側開始旋轉的力矩。(平均值，無負荷，環境溫度：25°C)

Input torque needed for input side to start rotating (average value, no load, ambient temperature : 25°C)

急停扭矩 Emergency Stop Torque

發生衝擊時的最大容許值

The maximum torque when it receives shock loading.

起動、停止時的容許峰值轉矩

Permissible Peak Torque for Start and Stop

起動、停止時，將因負載慣性力矩導致諧波減速機承受較恆定轉矩更大的負載。額定表中的數值，為此時的峰值轉矩容許值。

Load larger than the steady torque is applied to ROBONICDRIVE by the load inertia moment for start and stop. Values from the ratings show the acceptable value at peak torque.

負載轉矩模式範例 Example of Load Torque Pattern

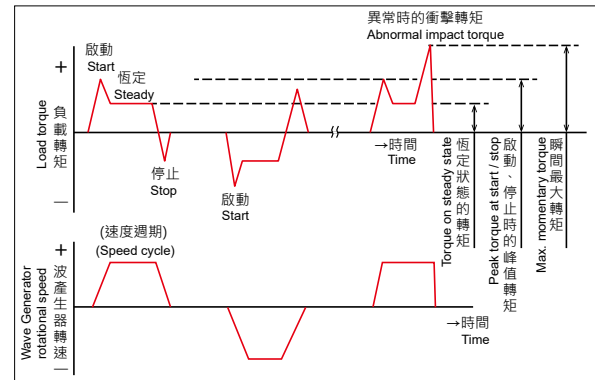

無負載運轉力矩 No-load Running Torque

在無負荷條件下轉速 2,000 r/min，使其旋轉所需必要的輸入側力矩。(平均值，無負荷，環境溫度：25°C)
Input torque needed to keep it running with no load speed 2,000 r/min (average value, no load, ambient temperature :25°C)

增速起動轉矩 Output Starting Torque

由輸出側使其旋轉時，輸入側開始旋轉的力矩。(平均值，無負荷，環境溫度：25°C)
Output torque needed for input side to start rotating (average value, no load, ambient temperature : 25°C)

最大輸出扭矩 Max. Output Torque

起動、停止時的最大容許值
The maximum torque when starting and stopping.

額定輸入轉速 Nominal Input Speed

運轉時，輸入轉速的容許值
The indicates permissible continuous running input speed.

噪音值 Noise Level

2,000 r/min 距離 1m 無負載量測
Noise level is measured in 2,000 r/min, without loading and in distance from the reducer.

效率 Efficiency

減速機效率會因以下條件有所差異

The efficiency varies depending on the following conditions.

- 減速比 Reducer Ratio
- 輸入轉速 Input Speed
- 負載轉矩 Load Torque
- 溫度 Temperature
- 潤滑條件 Lubrication Condition

樣本上的數值是輸入轉速 2,000 rpm 額定扭矩負載所測得平均值。

The efficiency in our catalog is average value tested at rated torque loading in input speed 2,000 r/min.

DSF / DSG 14-A□-50

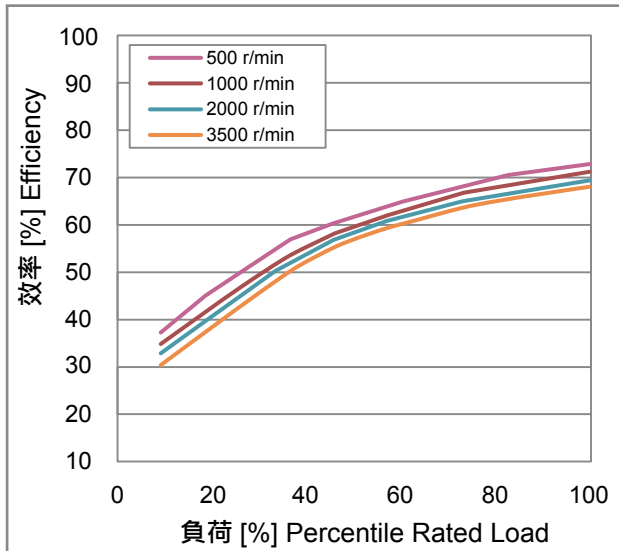

DSF / DSG 14-A□-80

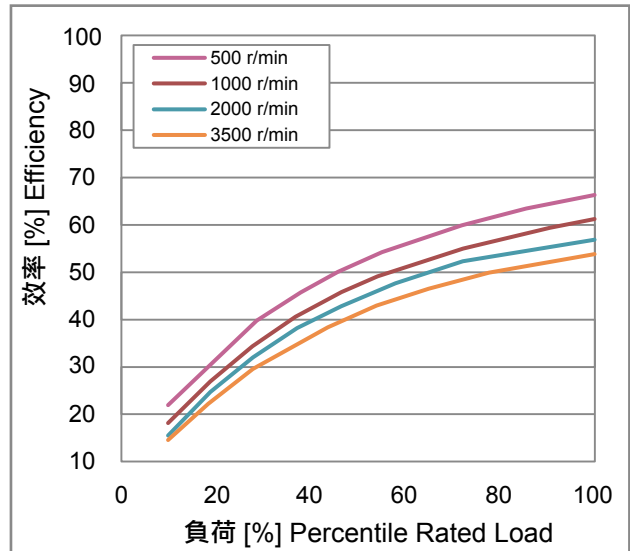

DSF / DSG 14-A□-100

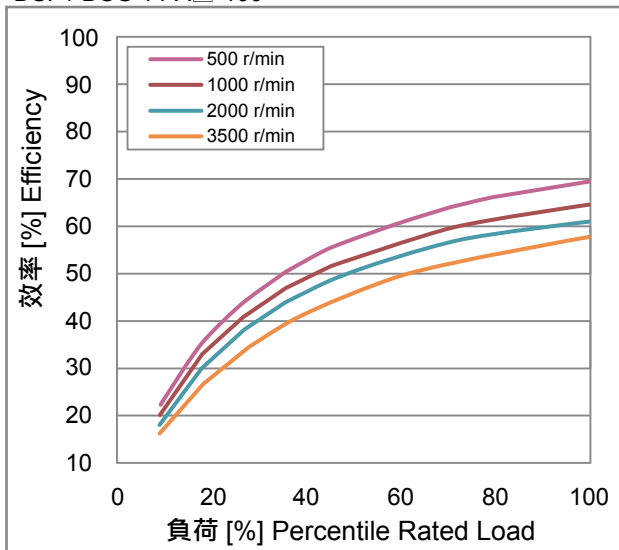

DSF / DSG 14-A□-120

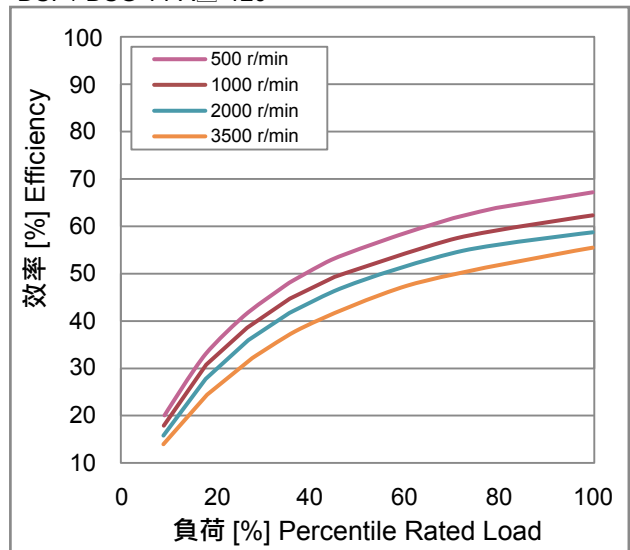



DSF DSG

諧波減速機

機種型號表示 Indication of Model Numbers

DSF		14	P		C	100	MOTOR
減速機機型 Type	型號 Model	樣式 Style	輸入樣式 Input Style	速比 Ratio	馬達型號 Motor Type		
DSF DSG	14 17 20 25 32 40	P: 組件式 Component Type A: 組合式 Unit Type MC: 法蘭式 Motor Flange Type S: 入力軸式 Input Shaft Type	C: 入力迫緊 Input Collet K: 入力鍵槽 Input Keyway 樣式 P、A 可以選擇 入力樣式 Input style is optional for style P, A.	1/50 1/80 1/100 1/120		型號 Model 14# 速比 Ratio 1/50 1/80 1/100	

DSF -PC-
DSG



DSF -AC-
DSG



DSF -MC-
DSG



DSF -PK-
DSG

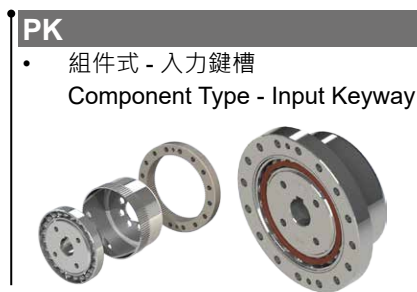

DSF -AK-
DSG



DSF -S-
DSG



DSF / DSG 產品特性 Characteristic of DSF / DSG

規格 Model No.	單位 Unit	減速比 Ratio	14	17	20	25	32	40
額定輸出扭矩 Nominal Output Torque	Nm	50	7	20	30	45	90	140
		80	9	27	40	72	138	209
		100	9	29	47	77	160	261
		120	-	29	47	77	160	298
平均負載最大轉矩 Max. Output Torque	Nm	50	9	32	40	64	127	200
		80	13	33	55	99	195	288
		100	13	48	58	123	253	377
		120	-	48	58	123	253	457
起動停止峰值轉矩 Emergency Stop Starting Torque	Nm	50	21	42	66	112	225	350
		80	27	53	86	157	316	452
		100	32	67	96	180	346	494
		120	-	67	102	191	367	537
起動轉矩 Starting Torque	cNm	50	4	6	8	15	32	55
		80	3	4	5	9	20	35
		100	2.5	3.5	4	8	18	32
		120	-	3	4	7	15	28
增速起動轉矩 Output Starting Torque	Nm	50	1.5	2.6	4.1	8.2	17	29
		80	1.6	2.7	4.2	8.4	18	30
		100	1.7	2.8	4.3	8.6	19	32
		120	-	2.9	4.5	8.8	20	34
無負載運轉力矩 No-load Running Torque	cNm	50	4	5	7	12	28	48
		80	3	4	6	10	20	30
		100	2	3	5	8	18	26
		120	-	3	4	7	14	25
額定輸入轉速 Nominal Input Speed	rpm	50~120	2,000	2,000	2,000	2,000	2,000	2,000
最大輸入轉速 Max. Input Speed	rpm	50~120	6,000	6,000	5,000	5,000	5,000	4,000
慣性力矩 Reducer Inertia	lx10-4kgm ²	50~120	0.04	0.08	0.2	0.4	1.7	4.5
效率 Efficiency	%	50	70	73	73	73	75	75
		80	68	70	72	72	74	74
		100	64	66	70	70	72	72
		120	-	64	68	68	70	70
使用溫度 Operating Temperature	°C	50~120	環境 Environment -10°C ~ +70°C / 最大工作溫度 Max. Working Temperature 90°C					
潤滑 Lubrication		50~120	潤滑油脂 Synthetic Grease					
噪音值 Noise Level	dB	50~120	52	54	56	58	60	62



MODEL : DSF-PC、DSG-PC

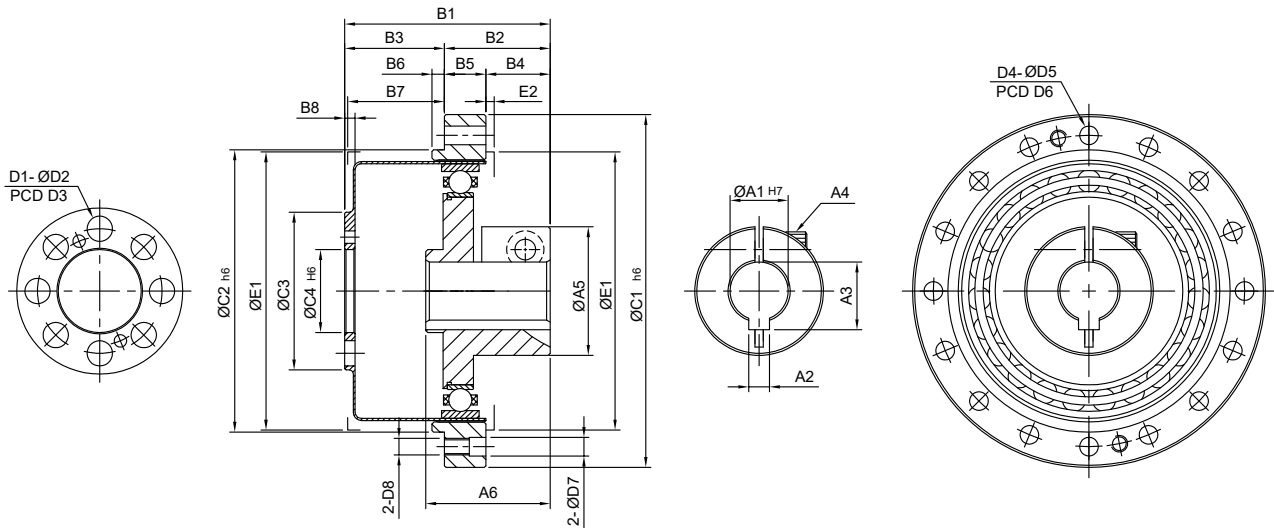
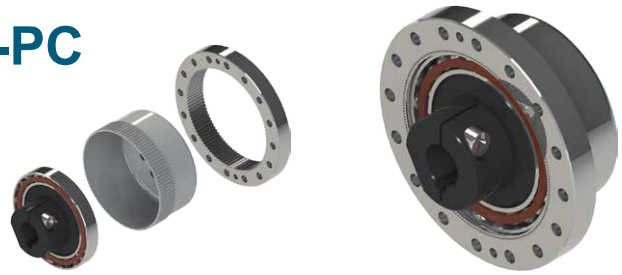

Code \ Model	14	17	20	25	32	40
A1	8	8	8、11、14	14	14、19	19
A2	3	3	3、4、5	5	5、6	6
A3	9.4	9.4	9.4、12.7、16.3	16.3	16.3、21.8	21.8
A4	M4xP0.7	M4xP0.7	M4xP0.7、M5xP0.8	M5xP0.8	M5xP0.8	M5xP0.8
A5	23.5	23.5	23.5、26、31	31	34、38	38
A6	22	23	25.5、27.5	30	32.5	36.5
B1	36	39	42.5、44.5	49.5	58	67.5
B2	18.5	19	21、23	25.5	30	33.5
B3	17.5	20	21.5	24	28	34
B4	12.5	12.5	13.5、15.5	15.5	16	16.5
B5	6	6.5	7.5	10	14	17
B6	2	2.5	3	3	3	4
B7	16.5	19	20.5	23	27	33
B8	2.4	3	3	3	3.2	4
C1	50	60	70	85	110	135
C2	38	48	54	68	90	110
C3	23	26	31	38	50	64
C4	11	10	14	20	26	32
D1	6	6	8	8	8	8
D2	4.1	5.1	5.1	6.1	8.1	10.1
D3	17	19	24	30	40	50
D4	DSG	8	16	16	16	16
	DSF	6	12	12	12	12
D5	3.5	3.4	3.5	4.5	5.5	6.6
D6	44	54	62	75	100	120
D7	-	-	3.5	4.5	5.5	6.6
D8	M3xP0.5	M3xP0.5	M3xP0.5	M4xP0.7	M5xP0.8	M6xP1.0
E1	37	46	53	67	86	105
E2	1.5	1.5	2	2	2	3
O-Ring	d35x1.0t	d44x1.2t	d51.82x1.5t	d63.22x1.78t	d84.5x2.0t	d107.62x2.62t
Weight (g)	132	195	300	495	1,018	3,383

MODEL : DSF-PK、DSG-PK

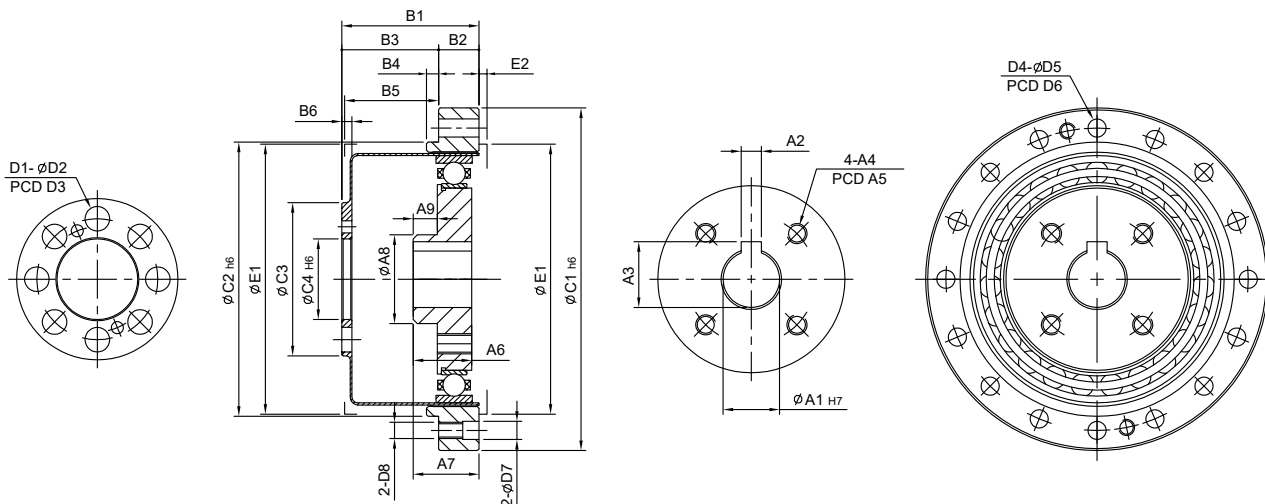
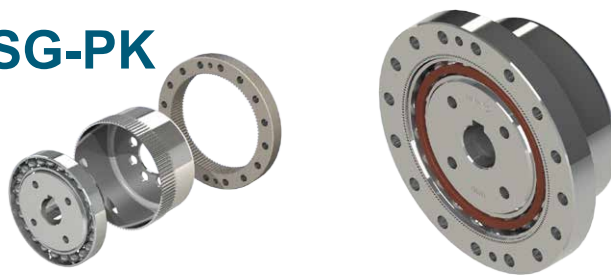

Code \ Model	14	17	20	25	32	40
A1	6、8	8	8、14	14	14、19	19、24
A2	2、3	3	3、5	5	5、6	6、8
A3	7、9.4	9.4	9.4、16.3	16.3	16.3、21.8	21.8、27.3
A4	2-M4xP0.7	2-M4xP0.7	M4xP0.7	M5xP0.8	M5xP0.8	M5xP0.8
A5	18	22	25	32	36	50
A6	10	12.5	13.5	14.5	16	20
A7	10.5	13	14	16.3	17.45	22
A8	14	16	21	24	30	36
A9	2.3	4.2	4.3	6	5	7
B1	23.5	26.5	29	34	42	51
B2	6	6.5	7.5	10	14	17
B3	17.5	20	21.5	24	28	34
B4	2	2.5	3	3	3	4
B5	16.5	19	20.5	23	27	33
B6	2.4	3	3	3	3.2	4
C1	50	60	70	85	110	135
C2	38	48	54	68	90	110
C3	23	26	31	38	50	64
C4	11	10	14	20	26	32
D1	6	6	8	8	8	8
D2	4.1	5.1	5.1	6.1	8.1	10.1
D3	17	19	24	30	40	50
D4	DSG	8	16	16	16	16
	DSF	6	12	12	12	12
D5	3.5	3.4	3.5	4.5	5.5	6.6
D6	44	54	62	75	100	120
D7	-	-	3.5	4.5	5.5	6.6
D8	M3xP0.5	M3xP0.5	M3xP0.5	M4xP0.7	M5xP0.8	M6xP1.0
E1	37	46	53	67	86	105
E2	1.5	1.5	2	2	2	3
O-Ring	d35x1.0t	d44x1.2t	d51.82x1.5t	d63.22x1.78t	d84.5x2.0t	d107.62x2.62t
Weight (g)	100	167	246	446	938	3,297

MODEL : DSF-AC、DSG-AC

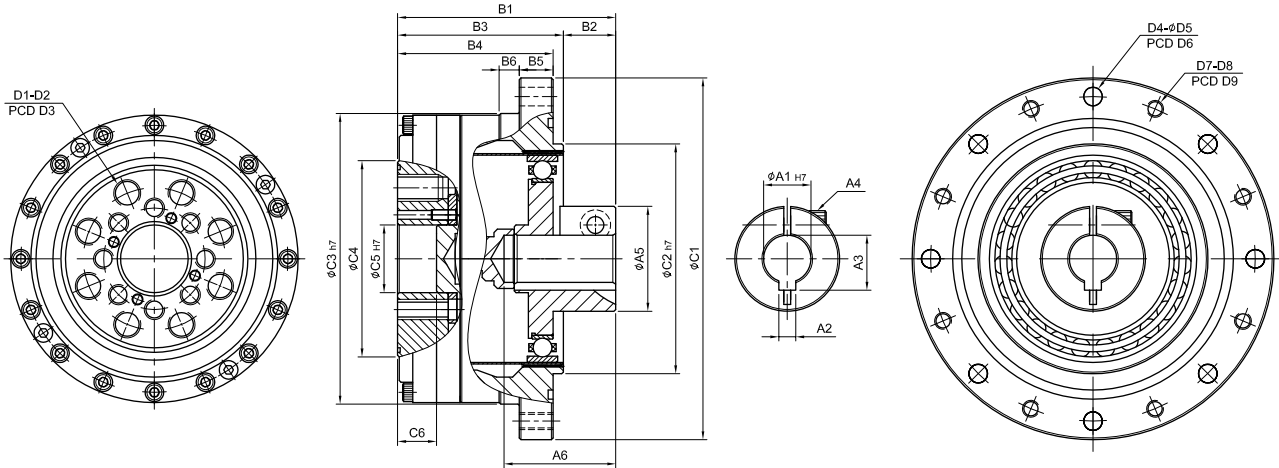

Code \ Model	14	17	20	25	32	40
A1	8	8	8、11、14	14	14、19	16、19
A2	3	3	3、4、5	5	5、6	6
A3	9.4	9.4	9.4、12.7、16.3	16.3	16.3、21.8	21.8
A4	M4xP0.7	M4xP0.7	M4xP0.7、M5xP0.8	M5xP0.8	M5xP0.8	M5xP0.8
A5	23.5	23.5	23.5、26.5、31	31	34、38	38
A6	23.5	24.5	27、29	33	38.5	46
B1	48.5	51.5	54.5、56.5	64.5	76	87
B2	12.5	12.5	13.5、15.5	15.5	16	16.5
B3	36	39	41	49	60	70.5
B4	34	37	38	46	57	66.5
B5	7	8	10	10	12	16
B6	4	5	6	6	5	5
C1	73	79	93	107	138	160
C2	38	48	56	67	90	110
C3	56	63	72	86	113	127
C4	31	38	45	58	78	90
C5	11	10	14	20	26	32
C6	9.4	9.5	9	12	15.2	5
D1	6	6	8	8	8	8
D2	M4xP0.7 deep12.5	M5xP0.8 deep12.5	M6xP1.0 deep12	M8xP1.25 deep15	M10xP1.5 deep18	M10xP1.5 deep19.5
D3	23	27	32	42	55	68
D4	DSG 8 DSF 6	8 6	8 6	10 8	12 12	10 8
D5	4.5	4.5	5.5	5.5	6.5	9
D6	65	71	82	96	125	144
D7	DSG 8 DSF 6	8 6	8 6	10 8	12 12	10 8
D8	M4xP0.7	M4xP0.7	M5xP0.8	M5xP0.8	M6xP1.0	M8xP1.25
D9	65	71	82	96	125	144
O-Ring	d49.5x2t	d55.5x2t	d66.5x2t	d79.5x2.0t	d104.5x2t	d124.5x2t
Output O-Ring	d29x0.6t	d35x0.6t	d43x1.5t	d55x1.5t	d72x1.5t	d85x1.5t
Weight (g)	555	733	1,039	1,629	3,463	5,174

MODEL : DSF-AK、DSG-AK

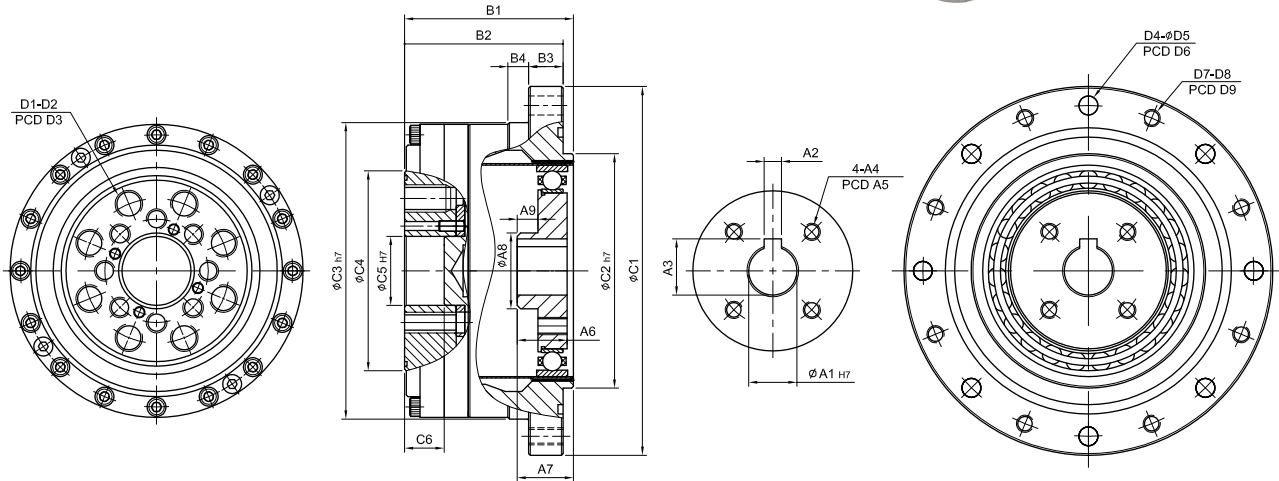

Code \ Model	14	17	20	25	32	40
A1	6、8	8	8、14	14	14、19	19、24
A2	2、3	3	3、5	5	5、6	6、8
A3	7、9.4	9.4	9.4、16.3	16.3	16.3、21.8	21.8、27.3
A4	2-M4xP0.7	2-M4xP0.7	M4xP0.7	M5xP0.8	M5xP0.8	M5xP0.8
A5	18	22	25	32	36	50
A6	10	12.5	13.5	14.5	16	20
A7	10.5	13	14	16.3	17.45	22
A8	14	16	21	24	30	36
A9	2.3	4.2	4.3	6	5	7
B1	36	39	41	49	60	70.5
B2	34	37	38	46	57	66.5
B3	7	8	10	10	12	16
B4	4	5	6	6	5	5
C1	73	79	93	107	138	160
C2	38	48	56	67	90	110
C3	56	63	72	86	113	127
C4	31	38	45	58	78	90
C5	11	10	14	20	26	32
C6	9.4	9.5	9	12	15.2	5
D1	6	6	8	8	8	8
D2	M4xP0.7 deep12.5	M5xP0.8 deep12.5	M6xP1.0 deep12	M8xP1.25 deep15	M10xP1.5 deep18	M10xP1.5 deep19.5
D3	23	27	32	42	55	68
D4	DSG 8 DSF 6	8 6	8 6	10 8	12 12	10 8
D5	4.5	4.5	5.5	5.5	6.5	9
D6	65	71	82	96	125	144
D7	DSG 8 DSF 6	8 6	8 6	10 8	12 12	10 8
D8	M4xP0.7	M4xP0.7	M5xP0.8	M5xP0.8	M6xP1.0	M8xP1.25
D9	65	71	82	96	125	144
O-Ring	d49.5x2t	d55.5x2t	d66.5x2t	d79.5x2.0t	d104.5x2t	d124.5x2t
Output O-Ring	d29x0.6t	d35x0.6t	d43x1.5t	d55x1.5t	d72x1.5t	d85x1.5t
Weight (g)	523	705	985	1,581	3,383	5,084

MODEL : DSF-MC、DSG-MC

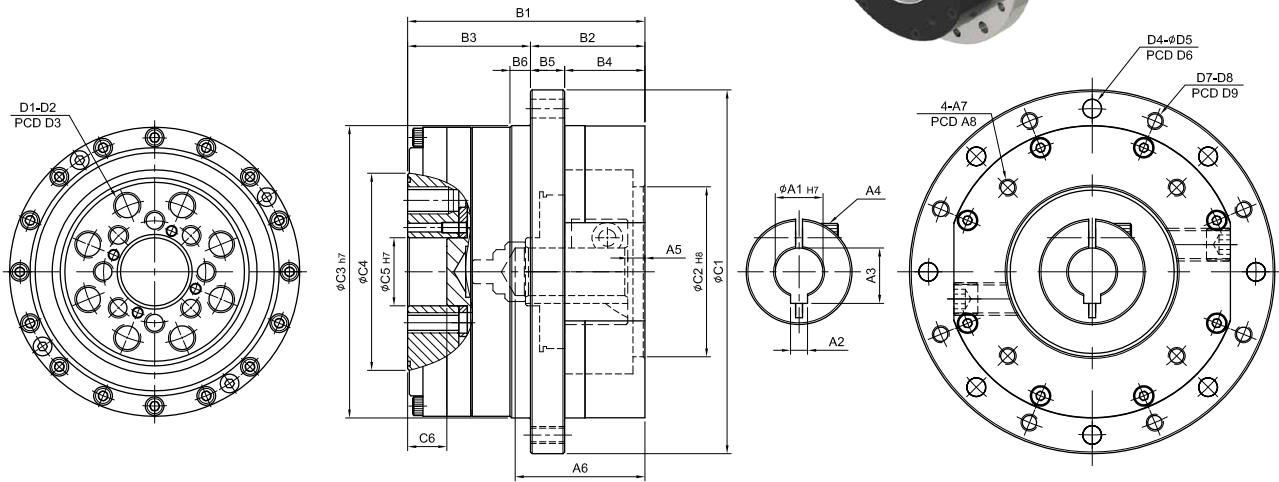

Code \ Model	14	17	20	25	32	40
A1	8	8	8、11、14	14	14、19	16、19
A2	3	3	3、4、5	5	5、6	5、6
A3	9.4	9.4	9.4、12.7、16.3	16.3	16.3、21.8	18.3、21.8
A4	M4xP0.7	M4xP0.7	M4xP0.7 M5xP0.8	M5xP0.8	M5xP0.8	M5xP0.8
A5	4	4	4、5	5	5	5
A6	27.5	28.5	31、34	38	43.5	51
A7	M3xP0.5 M4xP0.7	M3xP0.5 M4xP0.7	M4xP0.7 M5xP0.8	M5xP0.8	M4xP0.7、M5xP0.8 M6xP1.0	M5xP0.8 M6xP1.0
A8	45、46	45、46	46、63、70	70	65、70、90、100	70、90、98.43
B1	52.5	55.5	58.5、61.5	69.5	81	92
B2	25.5	26.5	30.5、33.5	33.5	36	41.5
B3	27	29	28	36	45	50.5
B4	18.5	18.5	20.5、23.5	23.5	24	25.5
B5	7	8	10	10	12	16
B6	4	5	6	6	5	5
C1	73	79	93	107	138	160
C2	30	30	30、40、50	50	36、50、70、80	50、70、73
C3	56	63	72	86	113	127
C4	31	38	45	58	78	90
C5	11	10	14	20	26	32
C6	9.4	9.5	9	12	15.2	5
D1	6	6	8	8	8	8
D2	M4xP0.7 deep12.5	M5xP0.8 deep12.5	M6xP1.0 deep12	M8xP1.25 deep15	M10xP1.5 deep18	M10xP1.5 deep19.5
D3	23	27	32	42	55	68
D4	DSG 8 DSF 6	8 6	8 6	10 8	12 12	10 8
D5	4.5	4.5	5.5	5.5	6.5	9
D6	65	71	82	96	125	144
D7	DSG 8 DSF 6	8 6	8 6	10 8	12 12	10 8
D8	M4xP0.7	M4xP0.7	M5xP0.8	M5xP0.8	M6xP1.0	M8xP1.25
D9	65	71	82	96	125	144
Output O-Ring	d29x0.6t	d35x0.6t	d43x1.5t	d55x1.5t	d72x1.5t	d85x1.5t
Weight (g)	633	836	1,155	1,831	3,881	5,673

MODEL : DSF-S 、 DSG-S

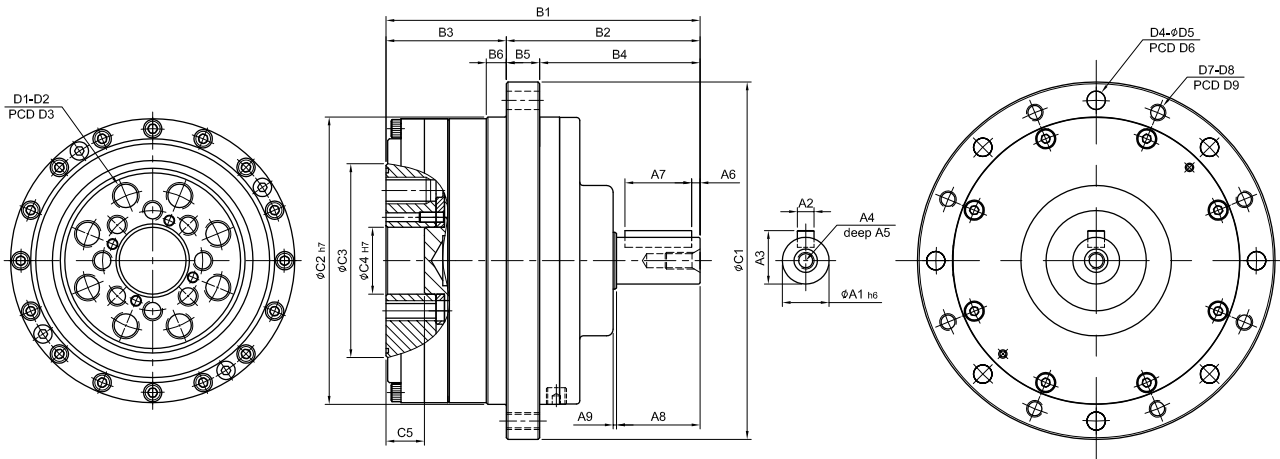

Code \ Model	14	17	20	25	32	40
A1	8	11	11	14	14	19
A2	3	4	4	5	5	6
A3	9.2	12.5	12.5	16	16	21.5
A4	M3xP0.5	M4xP0.7	M4xP0.7	M5xP0.8	M5xP0.8	M6xP1.0
A5	7	8	8	10	10	12
A6	1	1.5	2.5	2.5	2.5	2.5
A7	10	12	15	20	20	25
A8	12	16	20	25	25	30
A9	1	1	1	1	1	1
B1	63.5	70.5	78	94	113.5	129.5
B2	36.5	41.5	50	58	68.5	79
B3	27	29	28	36	45	50.5
B4	29.5	33.5	40	48	56.5	63
B5	7	8	10	10	12	16
B6	4	5	6	6	5	5
C1	73	79	93	107	138	160
C2	56	63	72	86	113	127
C3	31	38	45	58	78	90
C4	11	10	14	20	26	32
C5	9.4	9.5	9	12	15.2	5
D1	6	6	8	8	8	8
D2	M4xP0.7 deep12.5	M5xP0.8 deep12.5	M6xP1.0 deep12	M8xP1.25 deep15	M10xP1.5 deep18	M10xP1.5 deep19.5
D3	23	27	32	42	55	68
D4	DSG 8 DSF 6	8 6	8 6	10 8	12 12	10 8
D5	4.5	4.5	5.5	5.5	6.5	9
D6	65	71	82	96	125	144
D7	DSG 8 DSF 6	8 6	8 6	10 8	12 12	10 8
D8	M4xP0.7	M4xP0.7	M5xP0.8	M5xP0.8	M6xP1.0	M8xP1.25
D9	65	71	82	96	125	144
Output O-Ring	d29x0.6t	d35x0.6t	d43x1.5t	d55x1.5t	d72x1.5t	d85x1.5t
Weight (g)	620	818	1,125	1,842	3,972	5,882



DHG

諧波減速機

機種型號表示 Indication of Model Numbers

DHG	17	A	C	100	L	MOTOR
減速機機型 Type	型號 Model	樣式 Style	入力樣式 Input Style	速比 Ratio	軸向 Shaft Direction	馬達型號 Motor Type
DHG	14 17 20 25 32 40 45	A: 組合式 Unit Type O: 入力中空軸 Hollow Input Shaft S: 入力軸式 Input Shaft Type	C: 入力迫緊 Input Collet K: 入力鍵槽 Input Keyway O: 入力中空軸 Hollow Input Shaft ----- 入力形式 A 可以選擇 樣式 Input style is optional for style A.	1/50 1/80 1/100 1/120 ----- 型號 Model 14# 速比 Ratio 1/50 1/80 1/100	L: 左軸 Left Shaft R: 右軸 Right Shaft ----- 出力形式 O 可 以選擇軸向 Shaft direction is optional for style type O.	

DHG □ -AC- □

AC

- 組合式 - 入力迫緊
Unit Type - Input Collet



DHG □ -O- □

O

- 入力中空軸 Hollow Input Shaft



DHG □ -AK- □

AK

- 組合式 - 入力鍵槽
Unit Type - Input Keyway



DHG □ -S- □

S

- 入力軸式 Input Shaft Type



DHG □ -AO- □

AO

- 組合式 - 入力中空軸
Unit Type - Hollow Input Shaft



DHG 產品特性 Characteristic of DHG

規格 Model No.	單位 Unit	減速比 Ratio	14	17	20	25	32	40	45
額定輸出扭矩 Nominal Output Torque	Nm	50	7	20	30	45	90	140	180
		80	9	27	40	72	138	209	317
		100	9	29	47	77	160	261	358
		120	-	29	47	77	160	298	408
平均負載最大轉矩 Max. Output Torque	Nm	50	9	32	40	64	127	200	270
		80	13	33	55	99	195	288	395
		100	13	48	58	123	253	377	507
		120	-	48	58	123	253	457	629
起動停止峰值轉矩 Emergency Stop Starting Torque	Nm	50	21	42	66	112	225	350	450
		80	27	53	86	157	316	452	633
		100	32	67	96	180	346	494	677
		120	-	67	102	191	367	537	738
起動轉矩 Starting Torque	cNm	50	11	30	40	58	86	140	165
		80	10	28	36	56	80	130	150
		100	9	26	34	52	73	120	140
		120	-	24	30	48	68	110	125
增速起動轉矩 Output Starting Torque	Nm	50	2.5	3.5	4.5	8.5	18	32	43
		80	2.7	3.8	5	9	19	35	45
		100	2.8	4.2	5.5	9.5	21	37	48
		120	-	4.5	6	10	23	42	55
無負載運轉力矩 No-load Running Torque	cNm	50	4	6	8	15	30	53	70
		80	3	4	5.5	10	22	38	50
		100	2.5	3.5	5	9	20	33	45
		120	-	3.2	4.5	8	16	30	40
額定輸入轉速 Nominal Input Speed	rpm	50~120	2000	2000	2000	2000	2000	2000	2000
最大輸入轉速 Max. Input Speed	rpm	50~120	6000	6000	5000	5000	5000	4000	4000
慣性力矩 Reducer Inertia	lx10-4kgm ²	50~120	0.04	0.08	0.2	0.4	1.7	4.5	8.8
效率 Efficiency	%	50	70	73	73	73	75	75	75
		80	68	70	72	72	74	74	74
		100	64	66	70	70	72	72	72
		120	-	64	68	68	70	70	70
使用溫度 Operating Temperature	°C	50~120	環境 Environment -10°C ~ +70°C / 最大工作溫度 Max. Working Temperature 90°C						
潤滑 Lubrication		50~120	潤滑油脂 Synthetic Grease						
噪音值 Noise Level	dB	50~120	52	54	56	58	60	62	64



MODEL : DHG-AC

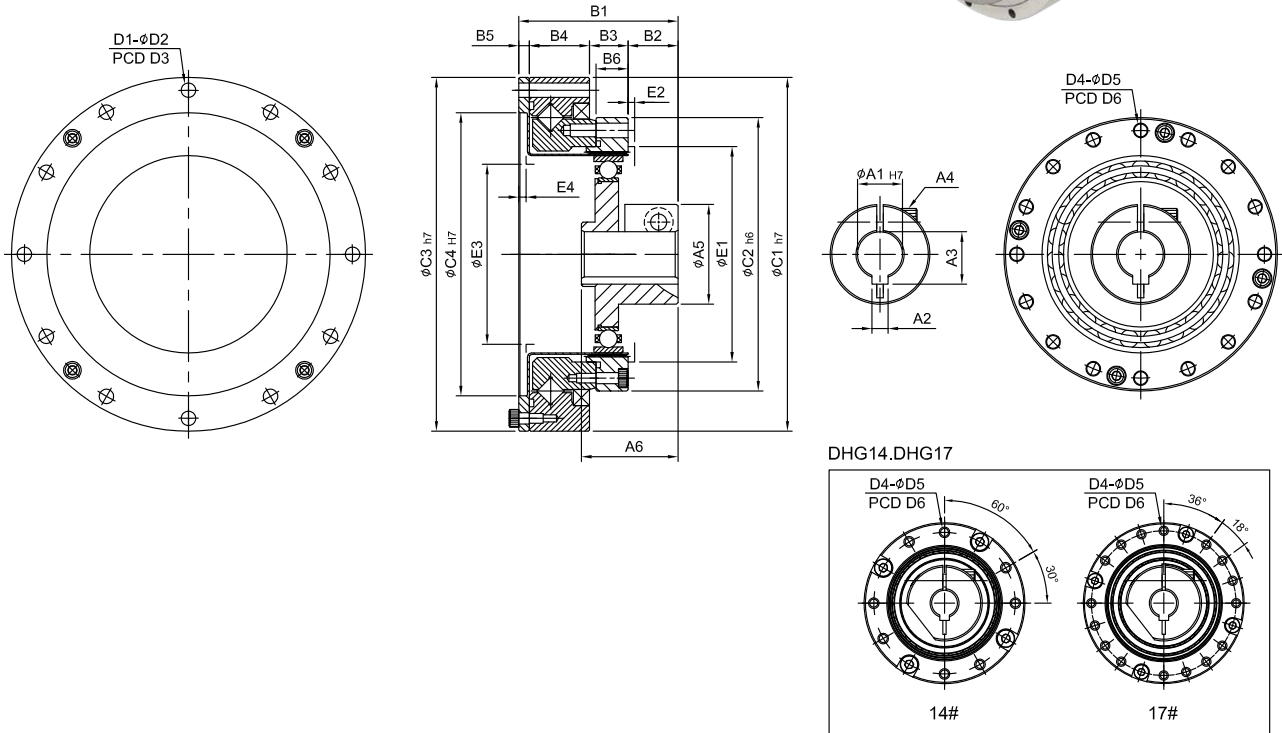

Code \ Model	14	17	20	25	32	40	45
A1	8	8	8、11、14	14	14、19	19	19
A2	3	3	3、4、5	5	5、6	6	6
A3	9.4	9.4	9.4、12.7、16.3	16.3	16.3、21.8	21.8	21.8
A4	M4xP0.7	M4xP0.7	M4xP0.7、M5xP0.8	M5xP0.8	M5xP0.8	M5xP0.8	M5xP0.8
A5	23.5	23.5	23.5、26.5、31	31	34、38	38	38
A6	22	23	25.5、27.5	30	32.5	36.5	38.5
B1	36	39.5	42.5、44.5	49.5	58	67	73
B2	12.5	13	13.5、15.5	15.5	16	16	16.5
B3	7	7.5	8.5	12	15	18	20
B4	14.1	16	17.5	18.7	23.4	29	32
B5	2.4	3	3	3.3	3.6	4	4.5
B6	6	6.5	7.5	10	14	17	19
C1	70	80	90	110	142	170	190
C2	50	60	70	85	110	135	155
C3	70	80	90	110	142	170	190
C4	48	60	70	88	114	140	158
D1	8	12	12	12	12	12	18
D2	3.5	3.5	3.5	4.5	5.5	6.5	6.5
D3	64	74	84	102	132	158	180
D4	8	16	16	16	16	16	12
D5	3.3 M3xP0.5x6L	3.5 M3xP0.5x6L	3.5 M3xP0.5x6L	4.5 M4xP0.7x8L	5.5 M5xP0.8x8L	6.5 M6xP1.0x10L	8.5 M8xP1.25x10L
D6	44	54	62	77	100	122	140
E1	38	46	54	67	86	106	119
E2	1.5	1.5	2	2	2	2	2
E3	30	36	44	56	72	92	105
E4	2	2	2	2	2	2.5	3
Weight (g)	312	595	811	1,328	2,707	4,628	6,732

MODEL : DHG-AK

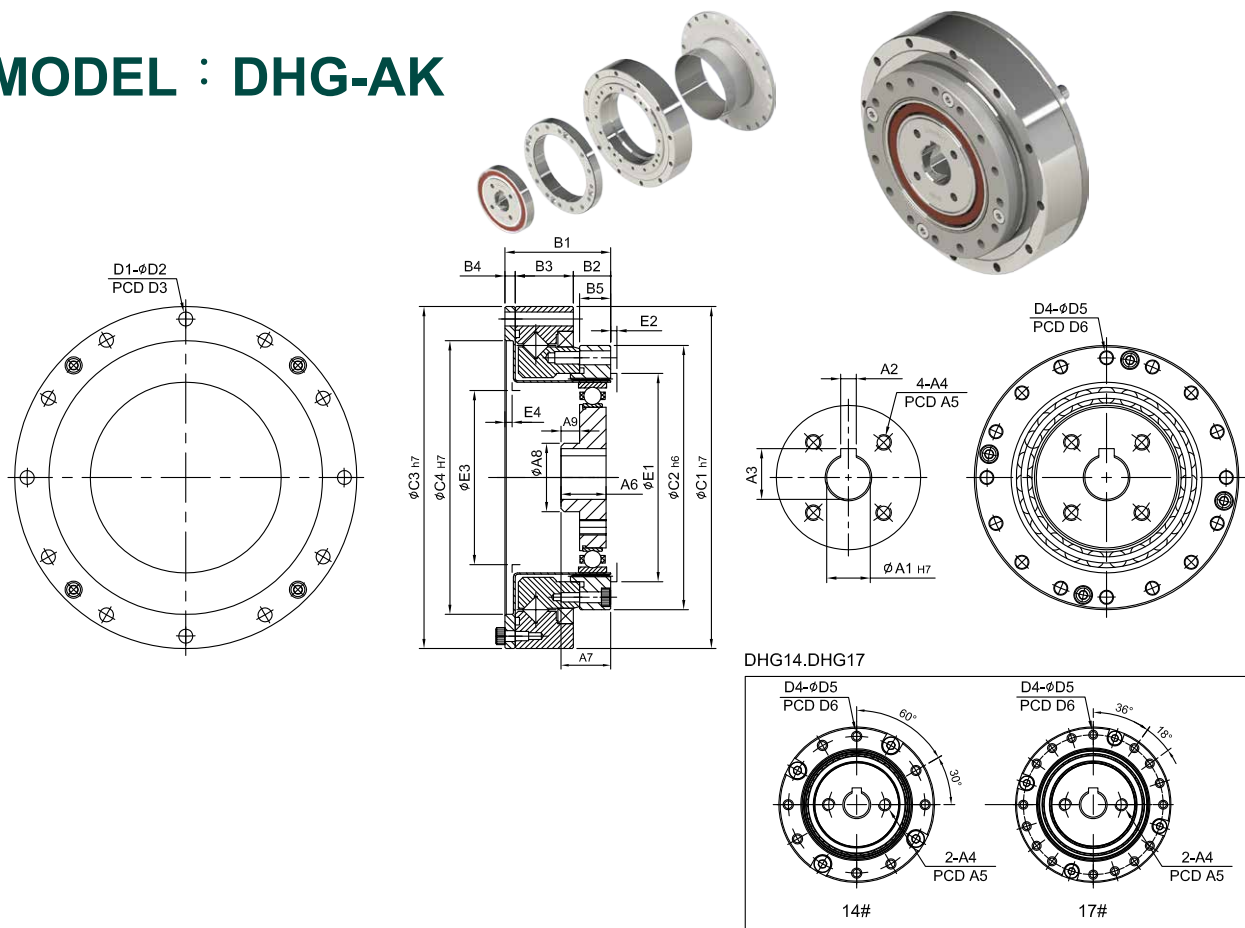

Code \ Model	14	17	20	25	32	40	45
A1	6、8	8	8、14	14	14、19	19、24	19、24
A2	3、3	3	3、5	5	5、6	6、8	6、8
A3	7、9.4	9.4	9.4、16.3	16.3	16.3、21.8	21.8、27.3	21.8、27.3
A4	2-M4xP0.7	2-M4xP0.7	M4xP0.7	M5xP0.8	M5xP0.8	M5xP0.8	M6xP1.0
A5	18	22	25	32	36	50	50
A6	10	12.5	13.5	14.5	16	20	20
A7	10.5	13	14	16.3	17.45	23	22
A8	14	16	21	24	30	36	36
A9	2.3	4.2	4.3	6	5	7	5
B1	23.5	26.5	29	34	42	51	56.5
B2	7	7.5	8.5	12	15	18	20
B3	14.1	16	17.5	18.7	23.4	29	32
B4	2.4	3	3	3.3	3.6	4	4.5
B5	6	6.5	7.5	10	14	17	19
C1	70	80	90	110	142	170	190
C2	50	60	70	85	110	135	155
C3	70	80	90	110	142	170	190
C4	48	60	70	88	114	140	158
D1	8	12	12	12	12	12	18
D2	3.5	3.5	3.5	4.5	5.5	6.5	6.5
D3	64	74	84	102	132	158	180
D4	8	16	16	16	16	16	12
D5	3.3 M3xP0.5x6L	3.5 M3xP0.5x6L	3.5 M3xP0.5x6L	4.5 M4xP0.7x8L	5.5 M5xP0.8x8L	6.5 M6xP1.0x10L	8.5 M8xP1.25x10L
D6	44	54	62	77	100	122	140
E1	38	46	54	67	86	106	119
E2	1.5	1.5	2	2	2	2	2
E3	30	36	44	56	72	92	105
E4	2	2	2	2	2	2.5	3
Weight (g)	280	567	757	1,280	2,628	4,536	6,642

MODEL : DHG-AO

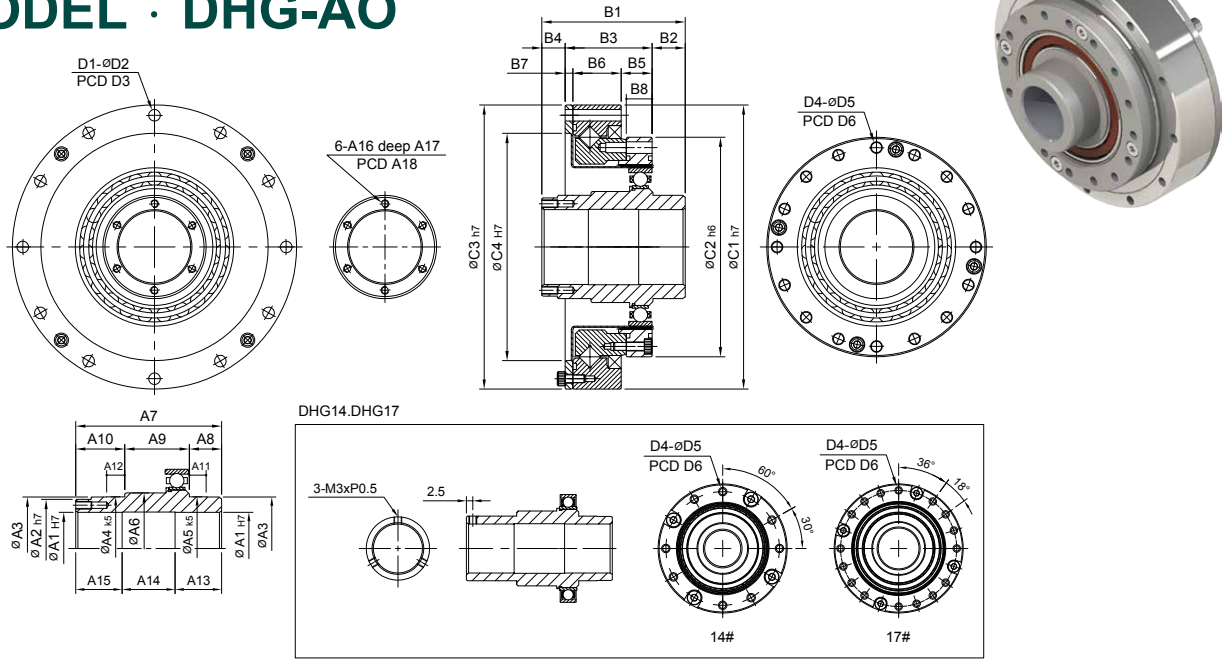

Code \ Model	14	17	20	25	32	40	45
A1	14	19	21	29	36	46	52
A2	20	25	30	38	45	59	64
A3	-	-	-	40	-	59	65
A4	20	25	30	40	45	60	65
A5	20	25	30	40	50	60	65
A6	24	29	34	43	50	65	70
A7	53	56.5	51.5	55.5	65.5	79	85
A8	13	13	13	12.5	13.5	16	19
A9	20.5	24	20.5	24	26	35	36
A10	19.5	19.5	18	19	26	28	30
A11	7	7	7	7	7	10	10
A12	7	7	8	7	12	13	13
A13	18	18.5	17	18	22	27	29
A14	17	19.5	17.5	19.5	21.5	25	27
A15	18	18.5	17	18	22	27	29
A16	3-M3xP0.5	3-M3xP0.5	M3xP0.5	M3xP0.5	M3xP0.5	M4xP0.7	M4xP0.7
A17	-	-	6	6	6	8	8
A18	-	-	25.5	33.5	40.5	52	58
B1	53	56.5	51.5	55.5	65.5	79	85
B2	13.5	14	13	11.5	11.5	15	15
B3	23.5	26.5	29	34	42	51	56.5
B4	16	16	9.5	10	12	13	13.5
B5	7	7.5	8.5	12	15	18	20
B6	14.1	16	17.5	18.7	23.4	29	32
B7	2.4	3	3	3.3	3.6	4	4.5
B8	6	6.5	7.5	10	14	17	19
C1	70	80	90	110	142	170	190
C2	50	60	70	85	110	135	155
C3	70	80	90	110	142	170	190
C4	48	60	70	88	114	140	158
D1	8	12	12	12	12	12	18
D2	3.5	3.5	3.5	4.5	5.5	6.5	6.5
D3	64	74	84	102	132	158	180
D4	8	16	16	16	16	16	12
D5	3.3	3.5	3.5	4.5	5.5	6.5	8.5
D6	M3xP0.5x6L	M3xP0.5x6L	M3xP0.5x6L	M4xP0.7x8L	M5xP0.8x8L	M6xP1.0x10L	M8xP1.25x10L
Weight (g)	340	630	848	1,416	2,736	4,659	6,849

MODEL : DHG-O

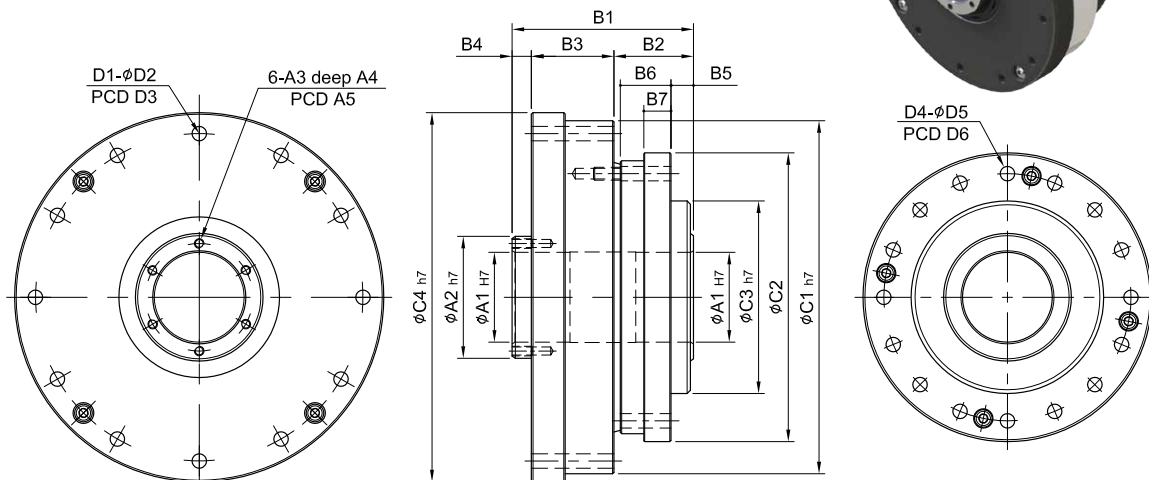

DHG14.DHG17

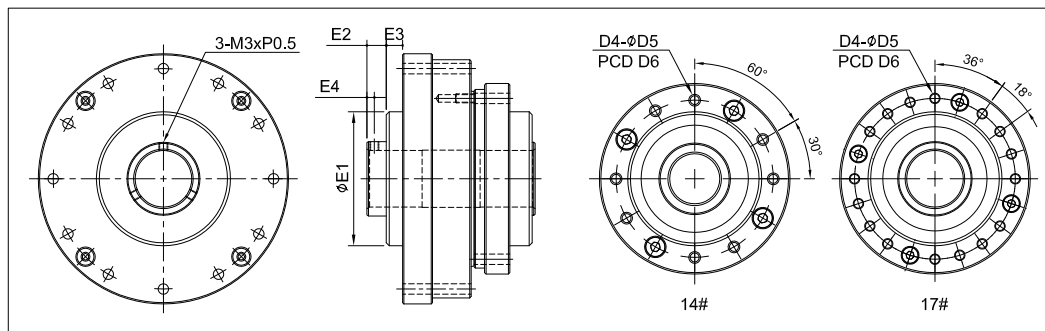

Code \ Model	14	17	20	25	32	40	45
A1	14	19	21	29	36	46	52
A2	20	25	30	38	45	59	64
A3	3-M3xP0.5	3-M3xP0.5	M3xP0.5	M3xP0.5	M3xP0.5	M4xP0.7	M4xP0.7
A4	-	-	6	6	6	8	8
A5	-	-	25.5	33.5	40.5	52	58
B1	53	56.5	51.5	55.5	65.5	79	85
B2	20.5	21.5	21.5	23.5	26.5	33	35
B3	20.5	23	25	26	32	38	42
B4	-	-	5	6	7	8	8
B5	8	8.5	7	6	5	7	7
B6	11.5	12	13.5	15.5	20.5	25	27
B7	8	8.5	9	8.5	9.5	13	12
C1	70	80	90	110	142	170	190
C2	54	64	75	90	115	140	160
C3	36	45	50	60	85	100	120
C4	74	84	95	115	147	175	195
D1	8	12	12	12	12	12	18
D2	3.5	3.5	3.5	4.5	5.5	6.5	6.5
D3	64	74	84	102	132	158	180
D4	8	16	16	16	16	16	12
D5	3.3	3.5	3.5	4.5	5.5	6.5	8.5
	M3xP0.5x6L	M3xP0.5x6L	M3xP0.5x6L	M4xP0.7x8L	M5xP0.8x8L	M6xP1.0x10L	M8xP1.25x10L
D6	44	54	62	77	100	122	140
E1	36	45	-	-	-	-	-
E2	6.5	6.5	-	-	-	-	-
E3	5.5	5.5	-	-	-	-	-
E4	2.5	2.5	-	-	-	-	-
Weight (g)	470	808	1,168	1,709	3,500	5,983	8,254

MODEL : DHG-OR

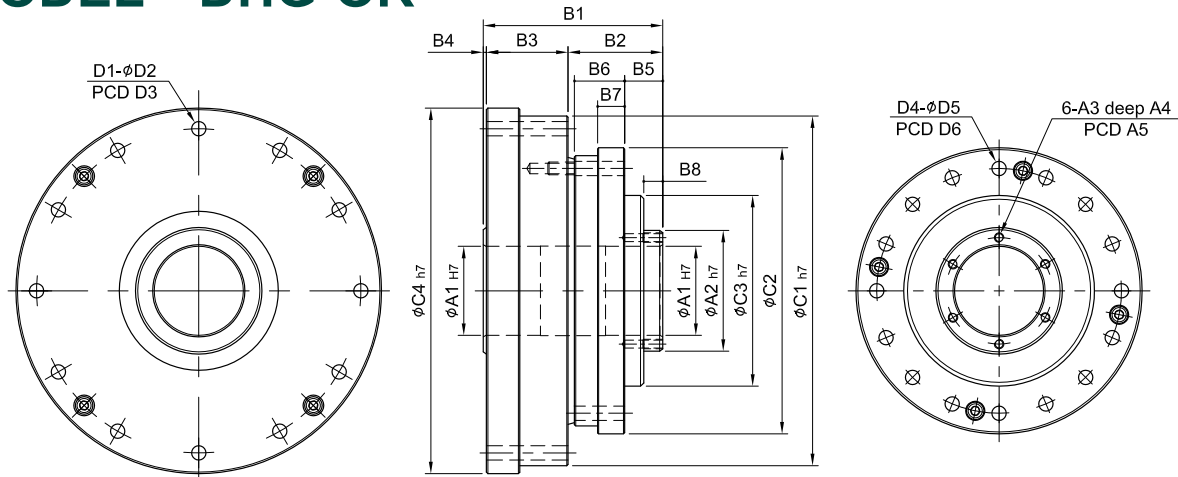

DHG14.DHG17

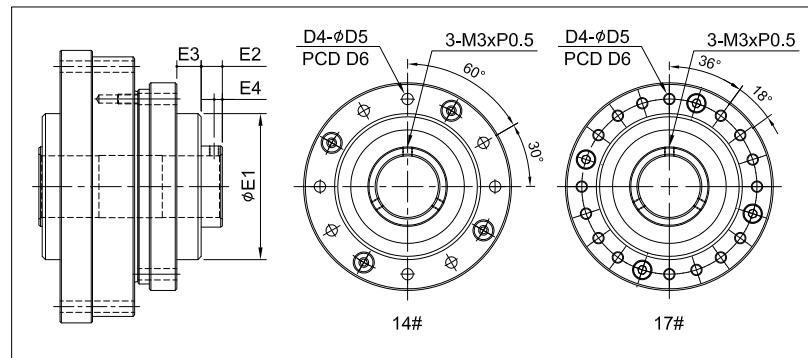

Code \ Model	14	17	20	25	32	40	45
A1	14	19	21	29	36	46	52
A2	20	25	30	38	45	59	64
A3	3-M3xP0.5	3-M3xP0.5	M3xP0.5	M3xP0.5	M3xP0.5	M4xP0.7	M4xP0.7
A4	-	-	6	6	6	8	8
A5	-	-	25.5	33.5	40.5	52	58
B1	53	56.5	51.5	55.5	65.5	79	85
B2	26.5	27	25.5	28.5	32.5	40	42
B3	20.5	23	25	26	32	38	42
B4	-	-	1	1	1	1	1
B5	14	14	11	11	11	14	14
B6	11.5	12	13.5	15.5	20.5	25	27
B7	8	8.5	9	8.5	9.5	13	12
B8	-	-	5	6	7	8	8
C1	70	80	90	110	142	170	190
C2	54	64	75	90	115	140	160
C3	36	45	50	60	85	100	120
C4	74	84	95	115	147	175	195
D1	8	12	12	12	12	12	18
D2	3.5	3.5	3.5	4.5	5.5	6.5	6.5
D3	64	74	84	102	132	158	180
D4	8	16	16	16	16	16	12
D5	3.3	3.5	3.5	4.5	5.5	6.5	8.5
D6	M3xP0.5x6L	M3xP0.5x6L	M3xP0.5x6L	M4xP0.7x8L	M5xP0.8x8L	M6xP1.0x10L	M8xP1.25x10L
E1	44	54	62	77	100	122	140
E2	36	45	-	-	-	-	-
E3	6.5	6.5	-	-	-	-	-
E4	7.5	7.5	-	-	-	-	-
E5	2.5	2.5	-	-	-	-	-
Weight (g)							

MODEL : DHG-S

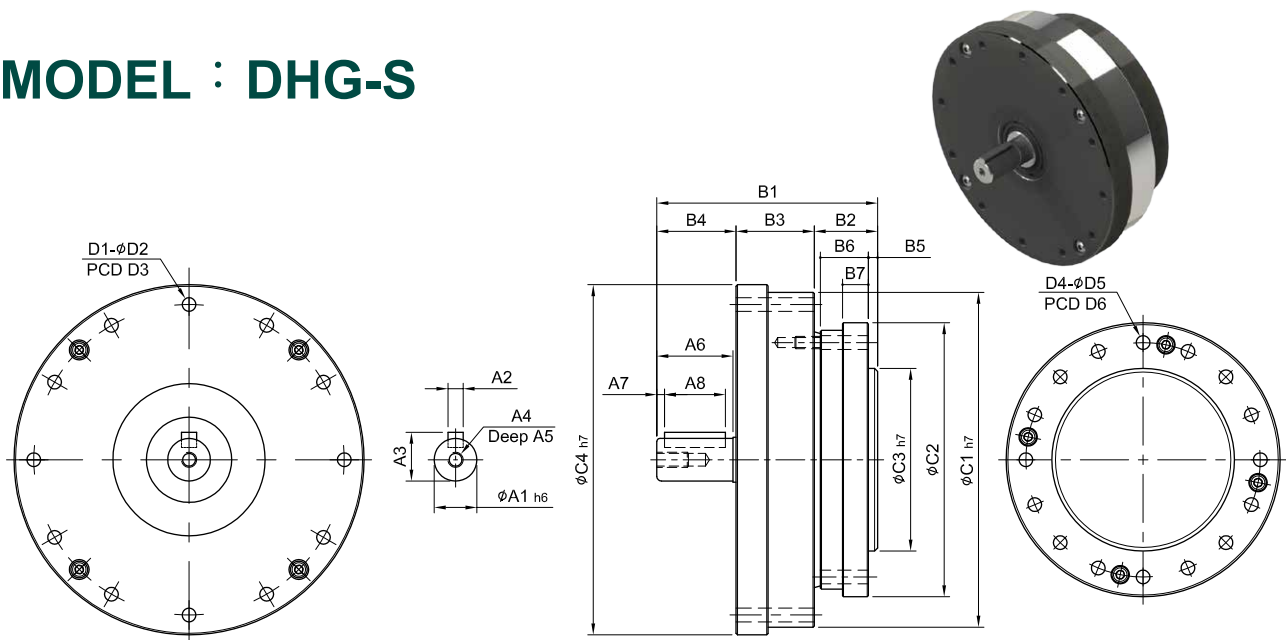

DHG14.DHG17

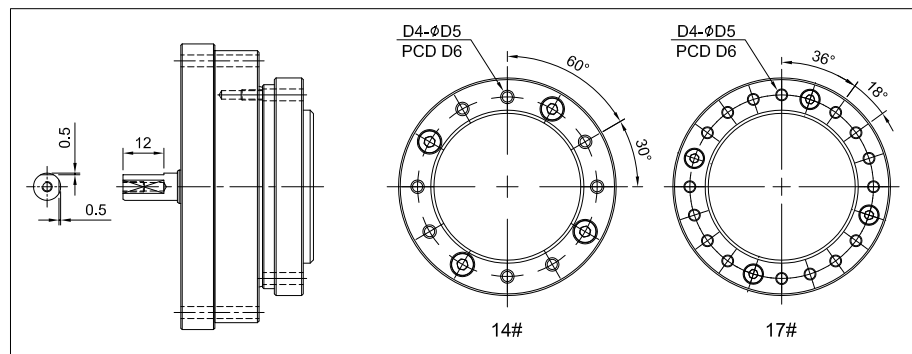

Code \ Model	14	17	20	25	32	40	45
A1	8	8	10	14	14	16	19
A2	-	-	3	5	5	5	6
A3	-	-	11.2	16	16	18	21.5
A4	M3xP0.5	M3xP0.5	M3xP0.5	M5xP0.8	M5xP0.8	M5xP0.8	M6xP1.0
A5	6	6	6	10	10	10	12
A6	14	16	20	25	25	30	30
A7	-	-	2.5	2.5	2.5	2.5	2.5
A8	-	-	15	20	20	25	25
B1	50.5	56	63.5	72.5	84.5	100	108
B2	15	15.5	17.5	20.5	26.5	31	35
B3	20.5	23	25	26	32	38	42
B4	15	17.5	21	26	26	31	31
B5	2.5	3	3	3	5	5	7
B6	11.5	11.5	13.5	15.5	20.5	25	27
B7	8	8.5	9	8.5	9.5	13	12
C1	70	80	90	110	142	170	190
C2	54	64	75	90	115	140	160
C3	36	45	50	60	85	100	120
C4	74	84	95	115	147	175	195
D1	8	12	12	12	12	12	18
D2	3.5	3.5	3.5	4.5	5.5	6.5	6.5
D3	64	74	84	102	132	158	180
D4	8	16	16	16	16	16	12
D5	3.3	3.5	3.5	4.5	5.5	6.5	8.5
D6	M3xP0.5x6L	M3xP0.5x6L	M3xP0.5x6L	M4xP0.7x8L	M5xP0.8x8L	M6xP1.0x10L	M8xP1.25x10L
Weight (g)	450	763	1,057	1,675	3,458	5,906	8,463

MODEL : DSS-14

RATIO : 100

精密旋轉平台 High Precision Rotary Reducer

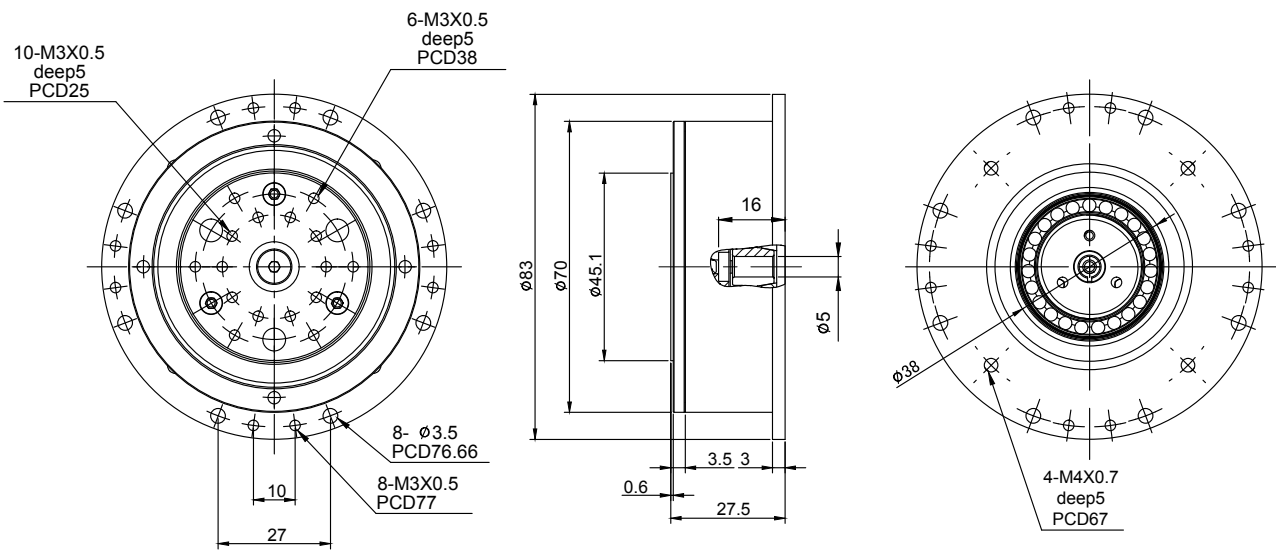
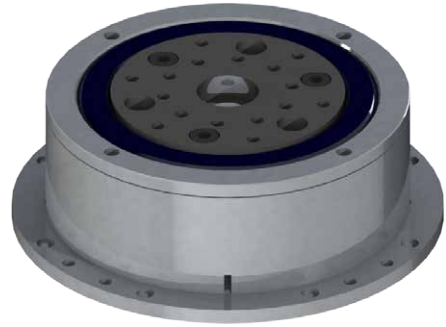

產品特性 Features

- 額定輸出扭矩 Nominal Output Torque : 9Nm
- 容許載重 Permissible Thrust Load : 100N
- 容許慣量載重 Permissible Moment Load : 10Nm



客製化諧波減速機 Customized ROBONICDRIVE

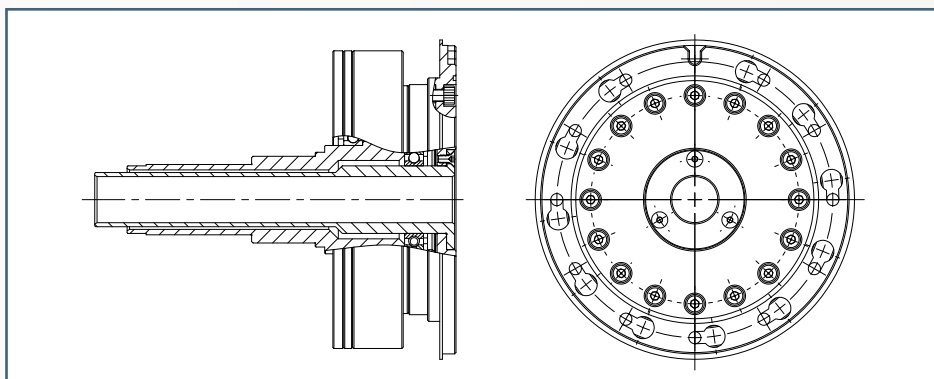
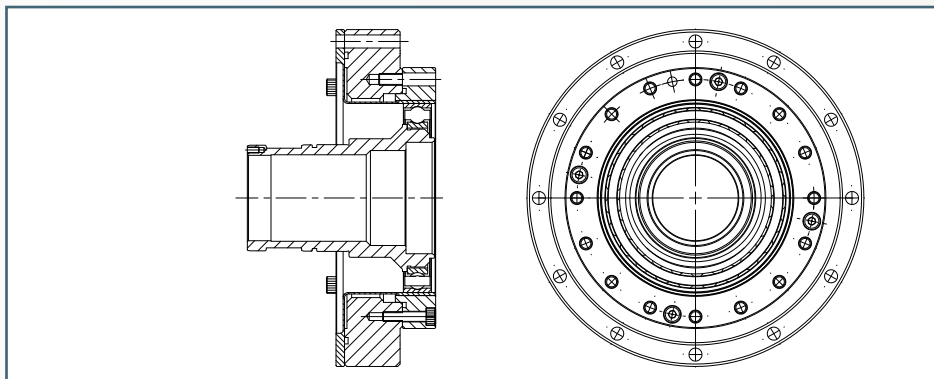
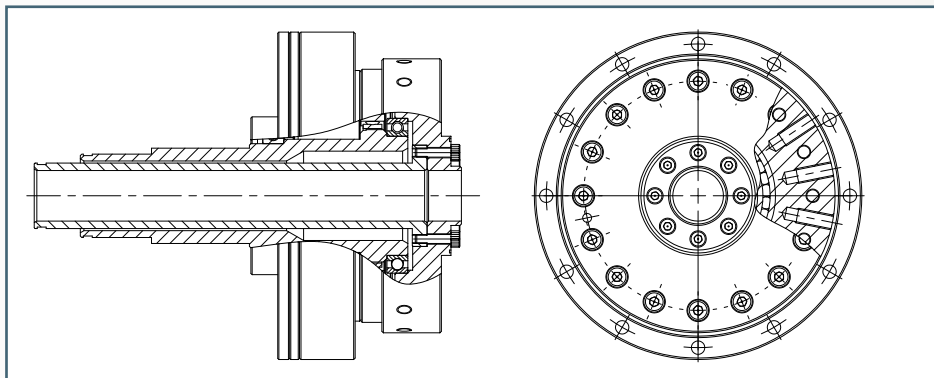
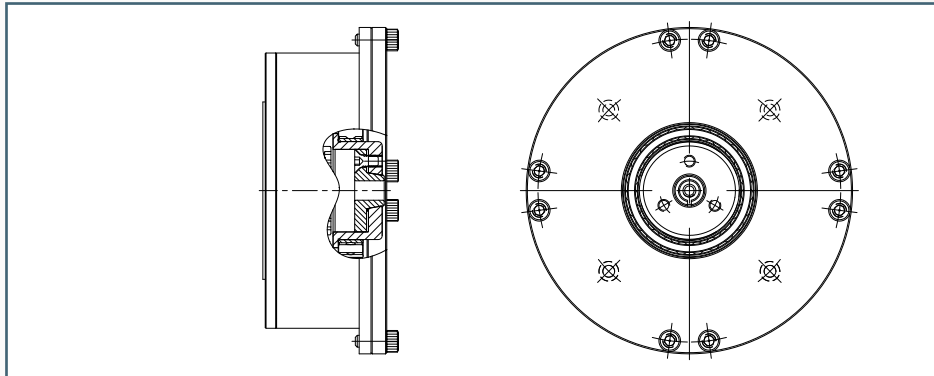

諧波減速機 DSF-MC 與馬達安裝指南 ROBONICDRIVE DSF-MC and Motor Mounting Instructions



核對馬達型號與減速機規格是否正確。並將配合面擦拭乾淨。
Confirm the motor, and gearbox size. Clean up the mounting surface.

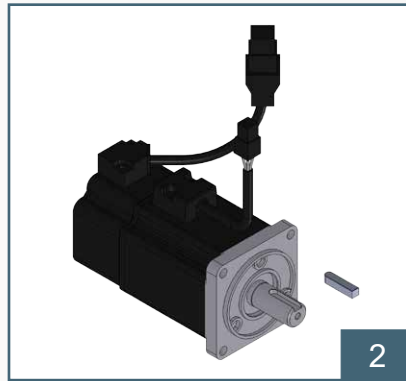

請使用帶油封之電機，避免潤滑脂洩漏至電機。
Please use a motor with oil seal to prevent grease leaking to the motor.

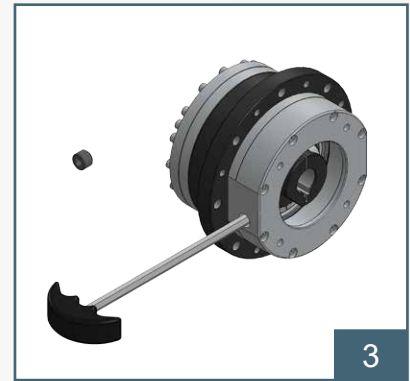

取出塞頭，使用六角板手將迫緊環螺絲鬆開。並將螺絲對準孔位。
Remove the plug on the adapter plate. Rotate the set collar till the bolt is line up.

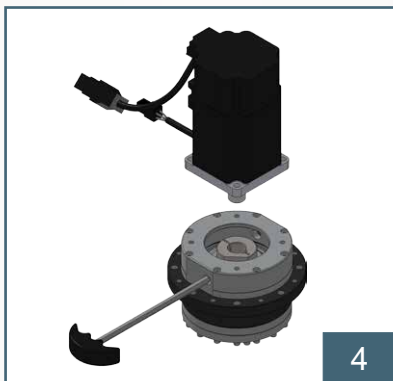

將馬達垂直裝入減速機。
Put the motor into the gearbox vertically.

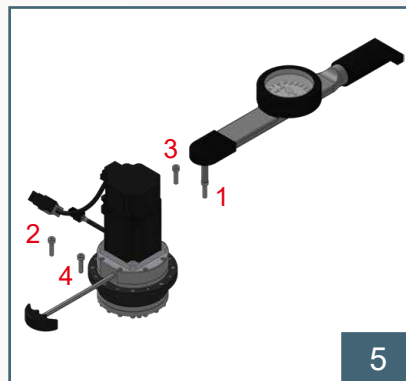

依序 1~4 使用扭力板手鎖上外六角螺絲。
Tighten the mounting bolt in 1~4 order with torque wrench.



使用扭力板手將迫緊環螺絲鎖緊。
Tighten the set collar bolt with torque wrench.

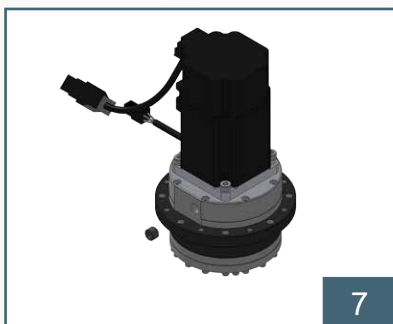

裝回塞頭。
Tighten back the screw plug.

1. 務必先鎖緊馬達，才能鎖緊馬達軸心迫緊環。
To be sure to tighten motor first and then to tighten the set collar on motor shaft.
2. 請依步驟順序組裝，尤其步驟 5、6 不可顛倒。
Please assembly in order according to above steps, especially for step 5 and step 6.