

VERTICAL REDUCER SERIES

多速比多段齒輪減速機系列

MODEL : LSVD

立式多速比雙軸減速機 Vertical Multi-Stage & Double Shaft Reducer

RATIO : 1/200~1/6000

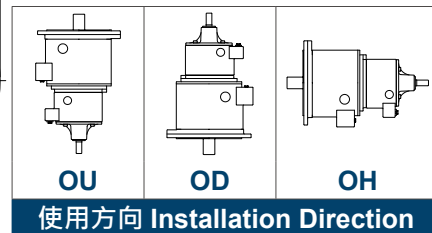
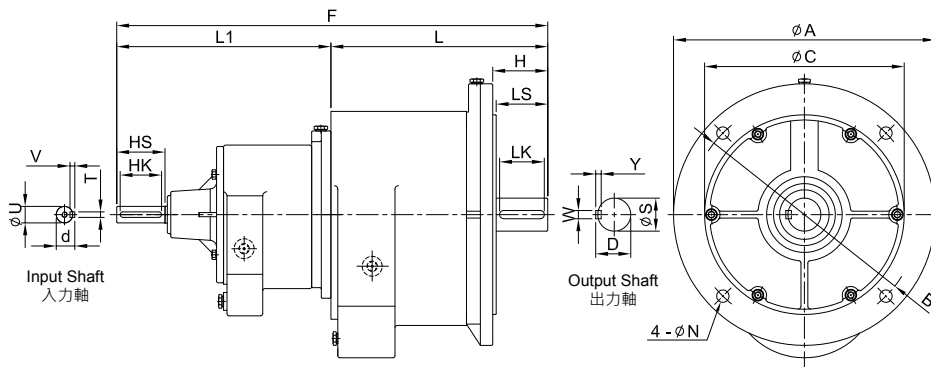

使用方向 Installation Direction

unit: mm

型號 Model	L	L1	F	法蘭面 Flange				入力軸 Input Shaft				出力軸 Output Shaft					重量 Weight (kg)
				A	B	C	N	d	HS	TxVxHK	U	D	LS	S	WxYxLK	H	
406	216	190	406	243	215	180	14	18	35	5x5x25	16	35	55	32	10x8x45	60	28
408	239	243	482	280	245	210	14	21	40	5x5x30	19	41	60	38	10x8x50	66	38
508	239	190	429	280	245	210	14	18	35	5x5x25	16	41	60	38	10x8x50	65	39
410	266		558	330	300	250											
410S	259	292	551	300	265	230	18	27	50	7x7x40	24	45	65	42	12x8x55	70	59
510	266	268	534	330	300	250	18	21	40	5x5x30	19	45	65	42	12x8x55	70	59
510S	259	266	525	300	265	230											
610	289		504	330	300	250	18	18	35	5x5x25	16	45	65	42	12x8x55	70	63
610S	282	215	497	300	265	230											
412	305		597	380	335	290	18	27	50	7x7x40	24	51	75	48	12x8x65	80	78
412S	282	292	574	340	300	250											
512	315		607	380	335	290	18	27	50	7x7x40	24	51	75	48	12x8x65	80	85
512S	296	292	588	340	300	250											
612	315		583	380	335	290	18	21	40	5x5x30	19	51	75	48	12x8x65	80	86
612S	296	268	564	340	300	250											
414	363	336	699	450													130
414S	361	329	690	440	400	350	22	31	55	7x7x45	28	66	85	62	15x10x75	90	128
514	378	293	656	450													127
514S	373	310	683	440	400	350	22	27	50	7x7x40	24	66	85	62	15x10x75	90	125
614	378	268	640	450													128
614S	373	310	683	440	400	350	22	21	40	5x5x30	19						
								27	50	7x7x40	24	66	85	62	15x10x75	90	126
								27	40	5x5x30	19						
								50	7x7x40	24							
416	434	336	770	500	450	400	24	31	55	7x7x45	28	80.5	100	76	20x12x90	105	181
416S		329	763														180
516	452	336	788	500	450	400	24	31	55	7x7x45	28	80.5	100	76	20x12x90	105	204
516S		329	781														203
616	452	353	805	500	450	400	24	27	50	7x7x40	24	80.5	100	76	20x12x90	105	206
616S		349	801														204
417	479	379	858	590	540	480	24	35	55	10x8x45	32	84.5	110	80	20x12x100	115	259
517	479	370	849	590	540	480	24	31	55	7x7x45	28	84.5	110	80	20x12x100	115	262
617	484	353	825	590	540	480	24	35	60	10x8x50	32	84.5	110	80	20x12x100	115	252
418	565	382	951	660	610	560	6x24	35	60	10x8x50	32	106.5	130	100	24x16x120	135	352
518	599	382	986	660	610	560	6x24	31	55	7x7x45	28	106.5	130	100	24x16x120	135	393
618	599	370	969	660	610	560	6x24	35	60	10x8x50	32	106.5	130	100	24x16x120	135	396

1. 表中 S 表示新尺寸。"S" means new dimension.

2. 重量不含馬達及潤滑油。The weight does not include motor and lubricant.