

GEAR REDUCER SERIES

齒輪減速機系列

MODEL : HD

臥式雙軸減速機 Horizontal Double Shaft Type Reducer
RATIO : 1/3~1/30 (雙段 2-Stage)

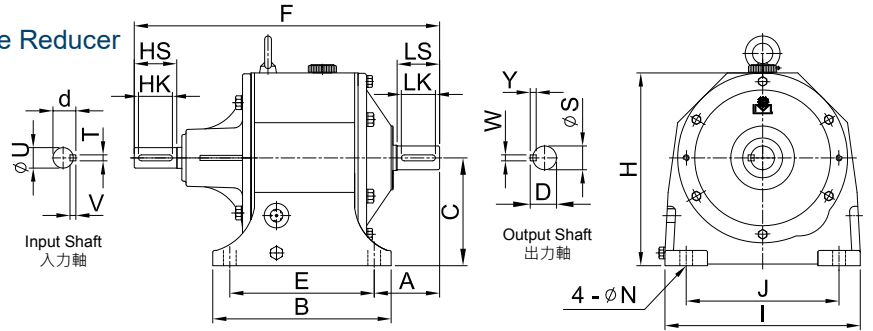

unit: mm

型號 Model	馬力 HP (4P)	減速比 Ratio	F	A	C	H	入力軸 Input Shaft				腳座 Foot Stock					出力軸 Output Shaft				重量 Weight (kg)	油量 Oil (ℓ)
							d	HS	TxVxHK	U	E	J	B	I	N	D	LS	S	WxYxLK		
201	1/4	3~30	251	54	90	170	18	35	5x5x25	16	125	140	155	180	10	21	38	19	5x5x30	10	0.5
202	1/2	3~10	264	60	90	170	21	40	5x5x30	19	125	140	155	180	10	27	45	24	7x7x35	10.5	0.5
203	1/4 1/2	31~50	264	62	110	190	18	35	5x5x25	16	135	145	170	190	13	27	45	24	7x7x35	12.5	0.7
		11~30	21				40	19													
205	1/2 1	31~50	357	77	127	227	27	50	7x7x40	24	170	180	210	230	15	31	50	28	7x7x40	22.5	1
		3~30																		27	
206	2	3~10	361	81	127	227	27	50	7x7x40	24	170	180	210	230	15	35	55	32	10x8x45	22.5	1
207	1 2	31~40	389	80	145	253	27	50	7x7x40	24	205	195	240	260	15	35	55	32	10x8x45	29	1.4
		11~30																			
208	3	3~10	394	85	145	265	27	50	7x7x40	24	205	195	240	260	15	41	60	38	10x8x50	31.5	1.4
209	2 3	31~40	419	88	164	289	31	55	7x7x45	28	215	215	265	295	19	41	60	38	10x8x50	42	2
		11~30				286															
209S	2 3	31~40	408	86	164	289	31	55	7x7x45	28	215	215	265	295	19	41	60	38	10x8x50	39	2
		11~30				286															
210	5	3~10	423	92	164	289	31	55	7x7x45	28	215	215	265	295	19	45	65	42	12x8x55	43	2
210S			413			286														280	
211	3 5	31~40	465	109	192	332	31	55	7x7x45	28	250	270	295	345	19	51	75	48	12x8x65	62	3
		11~30																			
211S	5	11~30	457	105	164	289	35	60	10x8x50	32	215	215	265	280	19	51	75	48	12x8x65	46	2.5
212	7 1/2 10	3~10	484	109	192	332	35	60	10x8x50	32	250	270	295	345	19	51	75	48	12x8x65	62	3
213	7 1/2 15	11~30	564	125	210	385	41	65	10x8x55	38	310	310	370	400	22	60	80	56	15x10x70	107	6.5
		3~10																			
213S	7 1/2 15	11~30	561	125	210	385	41	65	10x8x55	38	310	310	370	400	22	60	80	56	15x10x70	105	6.5
		3~10																			
214	10	11~30	569	130	210	385	41	65	10x8x55	38	310	310	370	400	22	66	85	62	15x10x75	108	6.5
214S			566			377														390	
215	15 20	11~30	697	157	245	445	51	80	12x8x70	48	360	360	430	450	25	76.5	100	72	20x12x90	178	10
		3~10																			
216	20 25	11~30	697	157	245	445	51	80	12x8x70	48	360	360	430	450	25	80.5	100	76	20x12x90	179	10
		5~10																			
217	25 30 40	11~30	733	172	280	505	51	80	12x8x70	48	380	420	460	530	25	84.5	110	80	20x12x100	235	15
		4~30 4~10																			
218	40 50 60	11~30	881	196	310	565	59	90	15x10x80	55	480	480	570	600	28	106.5	130	100	24x16x120	376	24
		5~10																			
219	50 60 75	11~30	970	214	380	670	69	100	15x10x90	65	540	500	635	670	28	124	150	115	32x20x140	565	32
		11~30 5~10																			
220	75	11~30	1,174	272	425	782	79.5	110	20x12x100	75	600	680	700	830	38	139	180	130	35x22x170	852	45

1. 表中 S 表示新尺寸。"S" means new dimension.

2. HD213(含) 以上有雙油鏡雙排油孔。The model above HD213 have dual oil gauges & drain plugs.

3. 重量不含馬達及潤滑油。The weight does not include motor and lubricant.

MODEL : HD

臥式雙軸減速機 Horizontal Double Shaft Type Reducer

RATIO : 1/31~1/200 (三段 3-Stage)

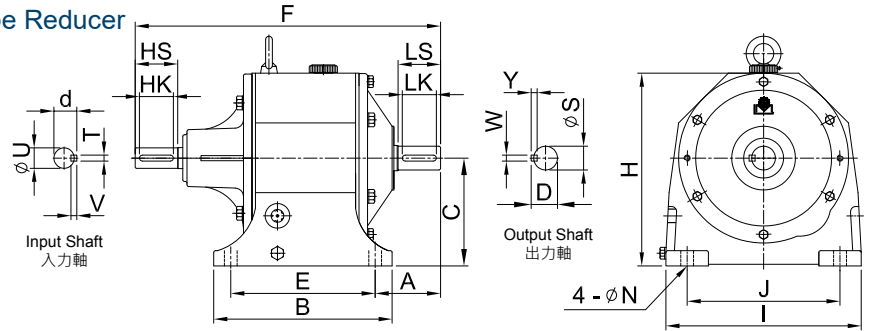

unit: mm

型號 Model	馬力 HP (4P)	減速比 Ratio	F	A	C	H	入力軸 Input Shaft				腳座 Foot Stock					出力軸 Output Shaft				重量 Weight (kg)	油量 Oil (ℓ)
							d	HS	TxVxHK	U	E	J	B	I	N	D	LS	S	WxYxLK		
304	1/4	51~120	280	68	110	190	18	35	5x5x25	16	135	145	170	190	13	31	50	28	7x7x40	14	0.7
306	1/4	121~200	322	81	127	227	18	35	5x5x25	16	170	180	210	230	15	35	55	32	10x8x45	23	1
	1/2	51~120	329				21	40	5x5x30	19											
308	1/2	121~200	361	85	145	253	21	40	5x5x30	19	205	195	240	260	15	41	60	38	10x8x50	33	1.4
	2	31~40	392				27	50	7x7x40	24											
310	1	121~200	441	92	164	289	27	50	7x7x40	24	215	215	265	295	19	45	65	42	12x8x55	42.5	2
	2	51~120																			
310S	1	121~200	432	92	164	286	27	50	7x7x40	24	215	215	265	295	19	45	65	42	12x8x55	40	2
	2	60~120																			
312	2	121~200	478	109	192	332	31	55	7x7x45	28	250	270	295	345	19	51	75	48	12x8x65	67	3
	3	41~120																			
312S	1	121~200	458	105	164	289	31	55	7x7x45	28	250	270	295	345	19	51	75	48	12x8x65	59	2.5
	2	51~120																			
314	3	121~200	572	130	210	385	35	60	10x8x50	32	310	310	370	22	66	85	62	15x10x75	113	6.5	
	5	60~120																			
314S	3	121~200	572	130	210	377	35	60	10x8x50	32	310	310	370	22	66	85	62	15x10x75	114	6.5	
	5	60~120																			
315	7 1/2	121~200	647	157	245	445	35	60	10x8x50	32	360	360	430	450	25	76.5	100	72	20x12x90	183	10
	10	60~120																			
316	10	60~120	671	157	245	445	41	65	10x8x55	38	360	360	430	450	25	80.5	100	76	20x12x90	198	10
	15	31~50																			
317	7 1/2	121~200	718	172	280	505	41	65	10x8x55	38	380	420	460	530	25	84.5	110	80	20x12x100	250	15
	15	40~120																			
318	20	150~200	807	196	310	565	41	65	10x8x55	38	480	480	570	600	28	106.5	130	100	24x16x120	410	24
	15	121~200																			
318	20	51~120	852	196	310	565	51	80	12x8x70	48	480	480	570	600	28	106.5	130	100	24x16x120	410	24
	25	60																			
	30	31~50																			
319	20	121~200	923	214	380	670	51	80	12x8x70	48	540	500	635	670	28	124	150	115	32x20x140	570	32
	25~30	70~90																			
	40	40~60	972	214	380	670	59	90	15x10x80	55	540	500	635	670	28	124	150	115	32x20x140	570	32

1. 表中 S 表示新尺寸。"S" means new dimension.

2. HD314 (含) 以上有雙油鏡雙排油孔。The model above HD314 have dual oil gauges & drain plugs.

3. 重量不含馬達及潤滑油。The weight does not include motor and lubricant.