

GEAR REDUCER SERIES

齒輪減速機系列

MODEL : HB

馬達插入式臥式減速機 Horizontal Type Reducer Motor Plug-In
RATIO : 1/3~1/30 (雙段 2-Stage)

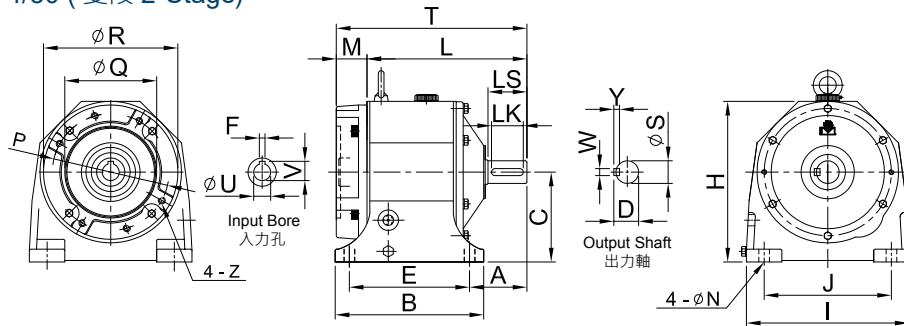

unit: mm

型號 Model	馬力 HP (4P)	減速比 Ratio	T	H	L	C	A	腳座 Foot Stock					馬達盤 IEC Motor Flange					入力孔 Input Bore			出力軸 Output Shaft				重量 Weight (kg)	油量 Oil (ℓ)	
								E	J	B	I	N	M	P	Q	R	Z	U	F	V	D	LS	S	WxYxLK			
201	1/4	3~30	194	170	165	90	54	125	140	155	180	10	29	130	110	158	M8	11	4	12.7	21	38	19	5x5x30	9	0.5	
202	1/2	3~10	201	170	172	90	60	125	140	155	180	10	29	130	110	158	M8	14	5	16.3	27	45	24	7x7x35	9	0.5	
203	1/4 1/2	31~50 11~30	209	190	180	110	62	135	145	170	190	13	29	130	110	158	M8	11 14	4 5	12.7 16.3	27	45	24	7x7x35	11.5	0.7	
205	1/2 1	31~50 3~30	248 255	227	222	127	77	170	180	210	230	15	26 34	130 165	110 130	200	M8 M10	14 19	5 6	16.3 21.8	31	50	28	7x7x40	19.5	1	
206	2	3~10	271	227	226	127	81	170	180	210	230	15	45	165	130	200	M10	24	8	27.3	35	55	32	10x8x45	21	1	
207	1 2	31~40 11~30	299	253	254	145	80	205	195	240	260	15	34 45	165	130	200	M10	19 24	6 8	21.8 27.3	35	55	32	10x8x45	29 26.5	1.4	
208	3	3~10	319	265	262	145	87	205	195	240	260	15	57	215	180	250	M12	28	8	31.3	41	60	38	10x8x50	30.5	1.4	
209	2 3	31~40 11~30	328 336	299	279									49 57	165 215	130 180		M10 M12	24 28						42 37.5		
209S	2 3	31~40 15~30	317 325	286	268	164	88	215	215	265		19	49 57	165 215	130 180		M10 M12	24 28	8	27.3 31.3	41	60	38	10x8x50	40 35	2	
210			340		283																				39		
210S	5	3~10	345	299	273	164	92	215	215	265		19	57	215	180	250	M12	28	8	31.3	45	65	42	12x8x55	37	2	
211	3 5	31~40 11~30	382	332	325	192	109	250	270	295	345		19	57	215	180	250	M12	28	8	31.3	51	75	48	12x8x65	59	3
211S	5	11~30	355	289	298	164	105	215	215	265	295														50	2.5	
212	7 1/2 10	3~10 3~10	390	332	325	192	109	250	270	295	345	19	65	265	230	300	M12	38	10	41.3	51	75	48	12x8x65	67	3	
213	7 1/2 15	11~30 3~10	450 475	385	385									65 88	265 300	230 250	300 350	M12 M16	38 42	10 12	41.3 45.3					105 109	
213S	7 1/2 15	11~30 3~10	447 482	377	382 394	210	125	310	310	370		22	65 88	265 300	230 250	300 350	M12 M16	38 42	10 12	41.3 45.3	60	80	56	15x10x70	98 102	6.5	
214			455	385																					105		
214S	10	11~30	455	377	390	210	130	310	310	370		22	65	265	230	300	M12	38	10	41.3	66	85	62	15x10x75	98	6.5	
215	15 20	11~30 3~10	559	445	471	245	157	360	360	430	450	25	88	300	250	350	M16	42	12	45.3	76.5	100	72	20x12x90	167	10	
216	20 25	11~30 5~10	559	445	471	245	157	360	360	430	450	25	88	300 350	250 300	350 390	M16	42 48	12 14	45.3 51.8	80.5	100	76	20x12x90	170	10	
217	25 30 40	11~30 4~30 4~10	595	505	508	280	172	380	420	460	530	25	88	350	300	390	M16	48	14	51.8	84.5	110	80	20x12x100	235	15	
218	40 50 60	11~30 5~10	695	565	608 626	310	196	480	480	570	600	28	88 100	350 400	300 350	390 450	M16	55 60	16 18	59.3 64.3	106.5	130	100	24x16x120	364 390	24	
219	50 60	11~30	776	670	676	380	214	540	500	635	670	28	100	400	350	450	M16	60	18	64.3	124	150	115	32x20x140	541.5	32	

- 表中 S 表示新尺寸。"S" means new dimension.
- HB213(含) 以上有雙油鏡雙排油孔。The model above HB213 have dual oil gauges & drain plugs.
- 重量不含馬達及潤滑油。The weight does not include motor and lubricant.

MODEL : HB

馬達插入式臥式減速機 Horizontal Type Reducer Motor Plug-In

RATIO : 1/31~1/200 (三段 3-Stage)

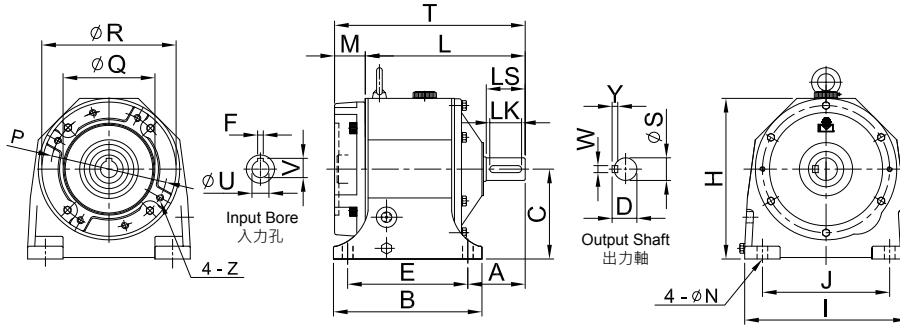

unit: mm

型號 Model	馬力 HP (4P)	減速比 Ratio	T	H	L	C	A	腳座 Foot Stock					馬達盤 IEC Motor Flange					入力孔 Input Bore			出力軸 Output Shaft				重量 Weight (kg)	油量 Oil (ℓ)
								E	J	B	I	N	M	P	Q	R	Z	U	F	V	D	LS	S	WxYxLK		
304	1/4	51~120	220	190	194	110	68	135	145	170	190	13	29	130	110	158	M8	11	4	12.7	31	50	28	7x7x40	12.5	0.7
306	1/4	121~200	265	227	236	127	81	170	180	210	230	15	29	130	110	200	M8	11	4	12.7	35	55	32	10x8x45	21.5	1
	1/2	51~120																								
308	1/2	121~200	285		259								26	130	110		M8	14	5	16.3						
	1	40~120	293	253	259	145	85	205	195	240	260	15	34	165	130	200	M10	19	6	21.8	41	60	38	10x8x50	29	1.4
310	2	31~40	313		268								45													
	1	121~200	344										49	165	130		M10	19	6	21.8					45	2
310S	2	51~120		289	295								24												43	
	1	60~120	334	286	286								24				M10	19	8	27.3						
312	2	121~200	386										49	165	130		M10	24		27.3						
	3	41~120	394	332	337	192	109	250	270	295	345	19	57	215	180	250	M12	28	8	31.3	51	75	48	12x8x65	65	3
312S	5	31~50											28													
	1	121~200	361	289	312	164	105	215	215	265	295		49	165	130		M10	19	6	21.8					57	2.5
314	2	60~120											24													
	3	121~200	470		413								57	215	180	250										
314S	5	60~120	467	385	402								38	10	41.3		M12	38	10	41.3	66	85	62	15x10x75	107	6.5
	7 1/2	31~50	464		402	210	130	310	310	370		22	65	265	230	300										
315	3	121~200	467		410								57	215	180	250										
	5	60~120	464		399								28	8	31.3											
315S	7 1/2	31~50	464		399								28	8	31.3											
	1	121~200	545		488								28	8	31.3											
316	7 1/2	60~120	557	445	492	245	157	360	360	430	450	25	65	265	230	300	M12	38	10	41.3	76.5	100	72	20x12x90	176	10
	10	31~50	580										88	300	250	350	M16	42	12	45.3						
317	15	60~120	604		539								65	265	230	300	M12	38	10	41.3						
	20	40~50	611	505	523	280	172	380	420	460	530	25	88	300	250	350	M16	42	12	45.3	84.5	110	80	20x12x100	239	15
318	10	150~200	693										65	265	230	300	M12	38	10	41.3						
	15	121~200	716		628								88	300	250	350										
318S	20	51~120	737	565	650	310	196	480	480	570	600	28					M16	42	12	45.3	106.5	130	100	24x16x120	394	24
	25	60	737										350	300	390											
319	30	31~50	787										42	14	51.8											
	40	121~200	808	670	699	380	214	540	500	635	670	28	88	300	250	350	M16	48	14	51.8	124	150	115	32x20x140	595	32

1. 表中 S 表示新尺寸。"S" means new dimension.
 2. HB314(含) 以上有雙油鏡雙排油孔。The model above HB314 have dual oil gauges & drain plugs.
 3. 重量不含馬達及潤滑油。The weight does not include motor and lubricant.