

# MODEL : RSN6

RATIO : 41、61、81、121

Unit: mm

Model Code	RSN6
A1	70、75、90
A2	M4、M5、M6
A3	50、60、70
A4	64、70、80

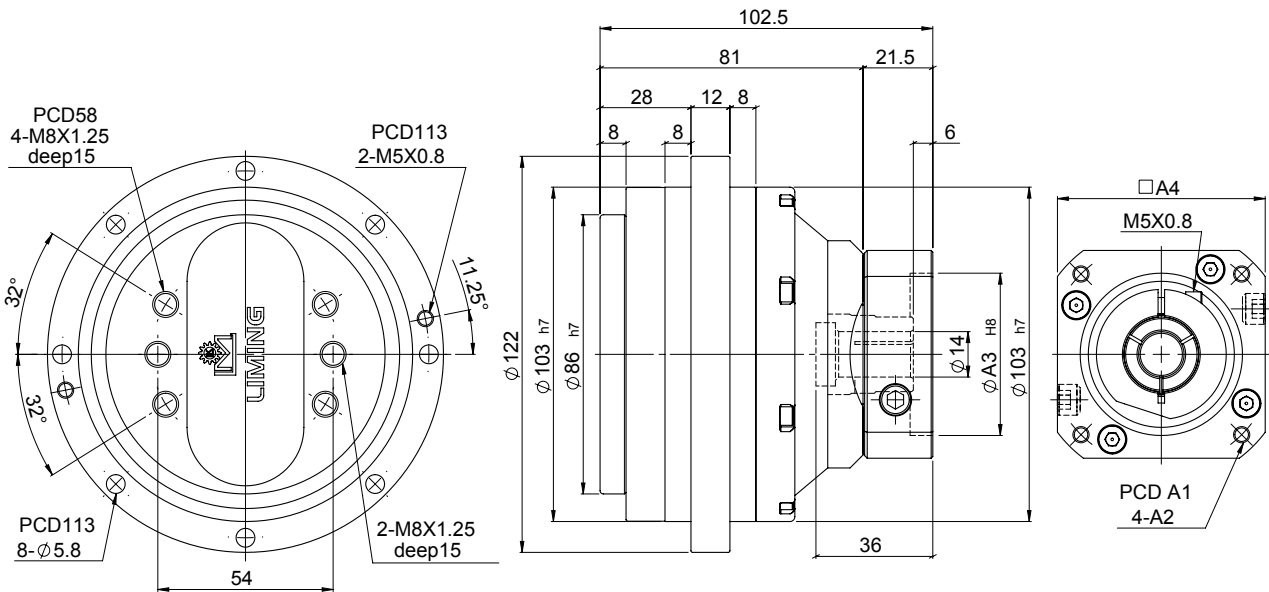

特性 Characteristic	代號	單位 Unit	RSN6
輸出平台支撐軸承 / Output Table Supporting Bearing			斜角滾珠軸承 Angular Contact Ball Bearing
額定輸出扭矩 / Rated Output Torque		Nm	60
最大輸出扭矩 / Max. Output Torque 急停扭矩 / Emergency Stop Torque	$T_{2NOT}$	Nm	5 倍額定輸出扭矩 5 Time of Rated Output Torque
最大加速力矩 / Max. Acceleration Torque	$T_{2B}$	Nm	2 倍額定輸出力矩 2 Times of Rated Output Torque
慣性慣量 / Inertia Moment		kg.m <sup>2</sup>	$0.31 \times 10^{-4}$
額定出力轉速 / Rated Output Speed		rpm	15
最大輸出轉速 / Max. Output Speed		rpm	55
容許輸入轉速 / Permissible Input Speed		rpm	3,000
背隙 / Backlash Ps	$J_i$	arcmin	≤ 2
背隙 / Backlash P0	$J_i$	arcmin	≤ 4
背隙 / Backlash P1	$J_i$	arcmin	≤ 6
容許徑向力 / Max. Radial Force	$F_{2rB}$	N	2,100
容許軸向力 / Max. Axial Force	$F_{2aB}$	N	1,500
額定壽命 / Rated Life	$L_H$	hr	S5 周期運轉 : >6,000 (S1 連續運轉 : >3,000 hrs) S5 Cycle Operation: >6,000 (S1 Continuous Operation: >3,000 hrs)
扭轉剛性 / Torsional Rigidity		Nm/arcmin	50
效率 / Efficiency	$\eta$	%	≥ 85
重量 / Weight		kg	3.3