

MODEL : RSE160

RATIO : 41、61、81、121、161

Unit: mm

Ratio Code	41、61、81、121	121
C	#6006	#6907
D	Ø30 ^{-0.01/-0.02}	Ø35 ^{-0.01/-0.02}
E	26.5	23.5
F	43.5	40.5

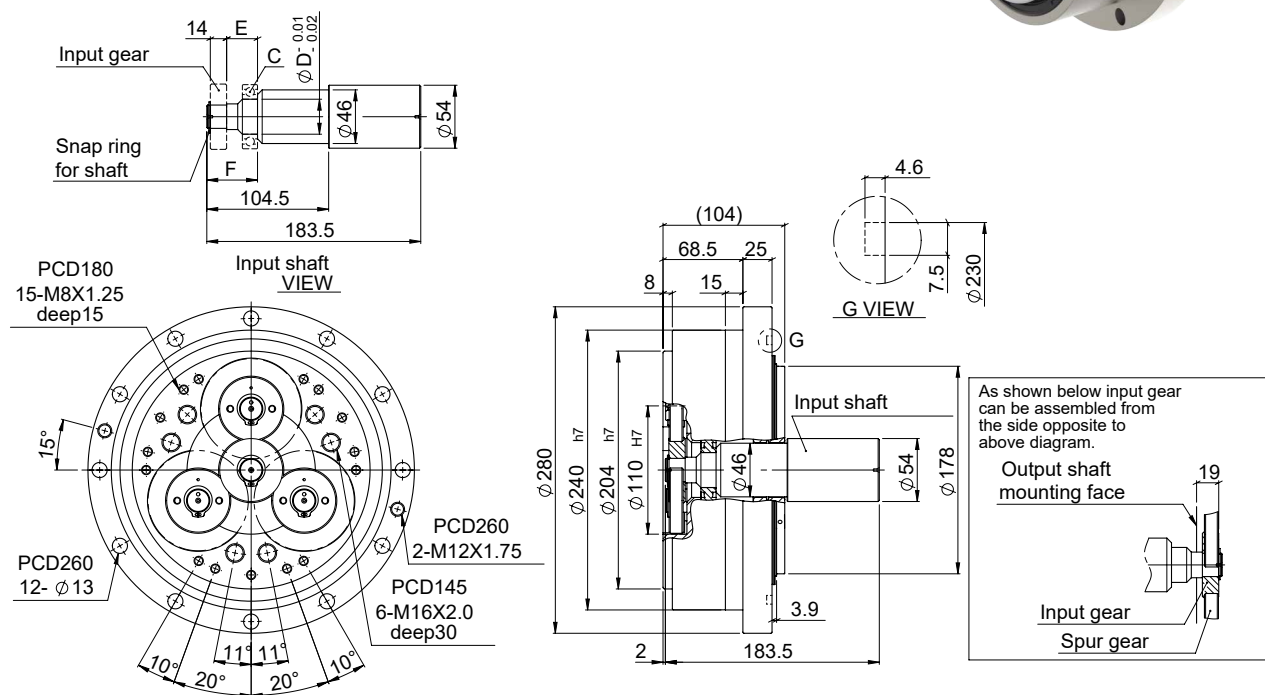

特性 Characteristic	代號	單位 Unit	RSE160
輸出平台支撐軸承 / Output Table Supporting Bearing			斜角滾珠軸承 Angular Contact Ball Bearing
額定輸出扭矩 / Rated Output Torque		Nm	1,600
最大輸出扭矩 / Max. Output Torque 急停扭矩 / Emergency Stop Torque	T_{2NOT}	Nm	5 倍額定輸出扭矩 5 Time of Rated Output Torque
最大加速力矩 / Max. Acceleration Torque	T_{2B}	Nm	2.5 倍額定輸出力矩 2.5 Times of Rated Output Torque
慣性慣量 / Inertia Moment		kg.m ²	7.37×10^{-4}
額定出力轉速 / Rated Output Speed		rpm	15
最大輸出轉速 / Max. Output Speed		rpm	27
容許輸入轉速 / Permissible Input Speed		rpm	3,000
背隙 / Backlash Ps	J_i	arcmin	≤ 1
背隙 / Backlash P0	J_i	arcmin	≤ 3
背隙 / Backlash P1	J_i	arcmin	≤ 5
容許徑向力 / Max. Radial Force	F_{2rB}	N	19,000
容許軸向力 / Max. Axial Force	F_{2aB}	N	15,000
額定壽命 / Rated Life	L_H	hr	S5 周期運轉 : >6,000 (S1 連續運轉 : >3,000 hrs) S5 Cycle Operation: >6,000 (S1 Continuous Operation: >3,000 hrs)
扭轉剛性 / Torsional Rigidity		Nm/arcmin	300
效率 / Efficiency	η	%	≥ 85
重量 / Weight		kg	31.7