

# MODEL : RCN80

RATIO : 78、104、130

Unit: mm

Model Code	RCN80
A1	90、100、115、145
A2	M5、M6、M8
A3	70、80、95、110
A4	92、110、130
A5	22、24
A6	6、8
A7	24.8、27.3

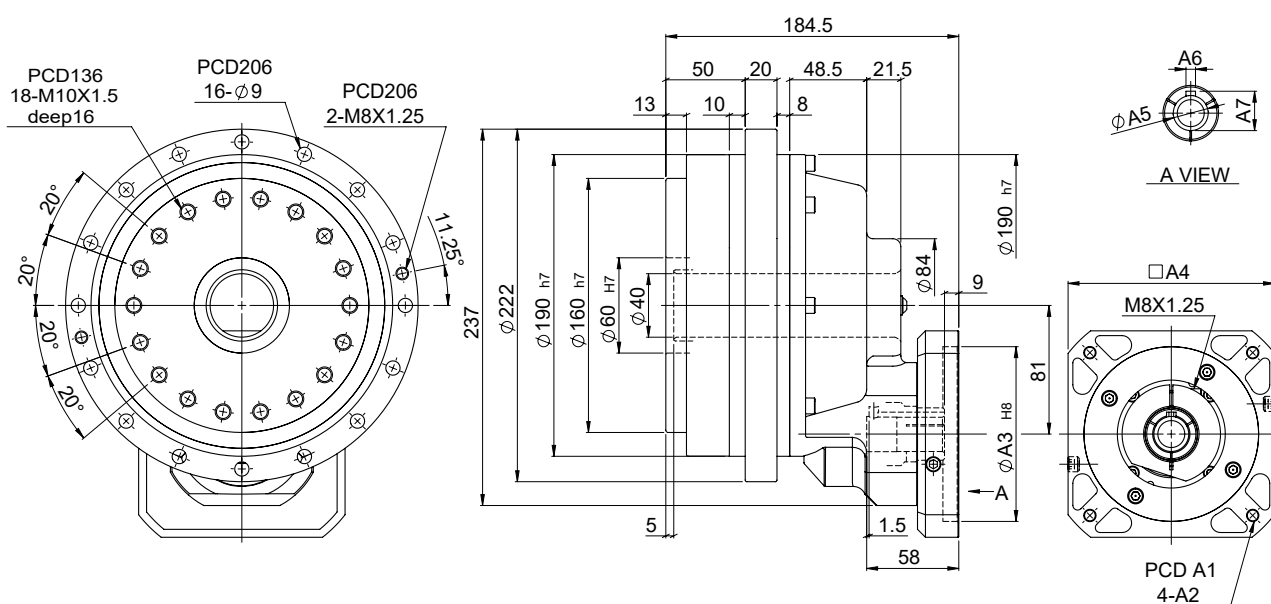

特性 Characteristic	代號	單位 Unit	RCN80
輸出平台支撐軸承 / Output Table Supporting Bearing			斜角滾珠軸承 Angular Contact Ball Bearing
額定輸出扭矩 / Rated Output Torque		Nm	800
最大輸出扭矩 / Max. Output Torque 急停扭矩 / Emergency Stop Torque	$T_{2NOT}$	Nm	5 倍額定輸出扭矩 5 Time of Rated Output Torque
最大加速力矩 / Max. Acceleration Torque	$T_{2B}$	Nm	2.5 倍額定輸出力矩 2.5 Times of Rated Output Torque
慣性慣量 / Inertia Moment		kg.m <sup>2</sup>	$2.63 \times 10^{-4}$
額定出力轉速 / Rated Output Speed		rpm	15
最大輸出轉速 / Max. Output Speed		rpm	42
容許輸入轉速 / Permissible Input Speed		rpm	3,000
背隙 / Backlash Ps	$J_i$	arcmin	≤ 1
背隙 / Backlash P0	$J_i$	arcmin	≤ 3
背隙 / Backlash P1	$J_i$	arcmin	≤ 5
容許徑向力 / Max. Radial Force	$F_{2rB}$	N	12,500
容許軸向力 / Max. Axial Force	$F_{2aB}$	N	8,200
額定壽命 / Rated Life	$L_H$	hr	S5 周期運轉 : >6,000 (S1 連續運轉 : >3,000 hrs) S5 Cycle Operation: >6,000 (S1 Continuous Operation: >3,000 hrs)
扭轉剛性 / Torsional Rigidity		Nm/arcmin	150
效率 / Efficiency	$\eta$	%	≥ 85
重量 / Weight		kg	19.3