

CYKODRIVE

高精密擺線減速機

CYKODRIVE Cycloidal Reducers



- CYKODRIVE 系列減速機是在擺線針輪傳動基礎上發展起來的一種傳動。
The CYKODRIVE series reducer is a type of transmission developed on the basis of cycloidal pinwheel transmission.
- 由漸開線圓柱齒輪行星減速機構和擺線針輪行星減速機構二部份構成。
It consists of two parts: the involute cylindrical gear planetary reduction mechanism and the cycloidal pinion planetary reduction mechanism.
- 漸開線行星齒輪與凸輪軸連成一體，作為擺線針輪傳動部分的輸入。
The involute planetary gear is integrated with the camshaft as an input to the cycloidal pinion drive section.
- 凸輪軸帶動擺線齒輪做偏心運動。凸輪軸向順時針方向旋轉 1 週，擺線齒輪將沿逆時針方向移動 1 個齒。
The camshaft drives the cycloidal gear to perform eccentric motion. The cam shaft rotates clockwise for 1 turn, and the cycloidal gear moves 1 tooth in the counterclockwise direction.

機種型號表示 Indication of Model Numbers

RS	N	20	—	41	—	P0	—	MOTOR
減速機機型 Type	入力表示 Input	型號 Model		速比 Ratio		背隙等級 Backlash Class		馬達型號 Motor Type
RS RD RC	E: 組件式 Component Type N: 入力法蘭 Motor Flange Type S: 入力軸式 Input Shaft Type L: 入力直交 Right Angle	6 20 40 80 110 160 320 450		41 ~ 171 Note 1		Ps ≤ 1 arcmin P0 ≤ 3 arcmin P1 ≤ 5 arcmin		

[Note 1] 有關各個機型型號的速比，請參見尺寸頁面。
See the dimension page for gear ratio details.

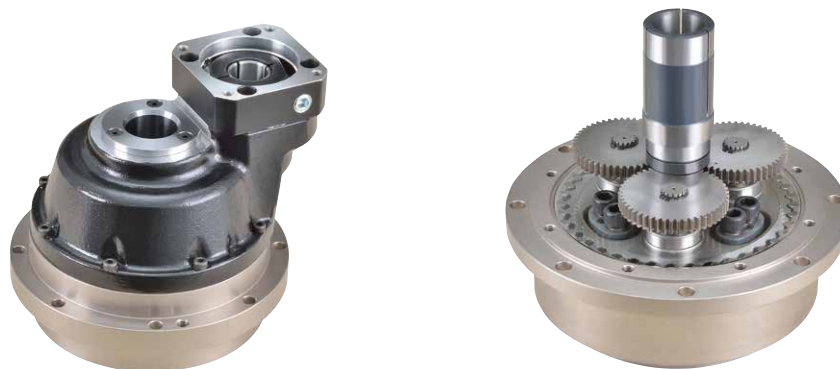

旋轉方向與速比如下圖所示，請選擇最佳使用方法：

The housing is fixed, and the output shaft drive:

- ① 減速機箱體外殼固定，由出力軸輸出的情況：出力軸的旋轉方向與輸入軸的旋轉方向相同。減速比等於型錄上的公稱減速比。
The gearbox casing is fixed, with output from the output shaft:
The rotation direction of the output shaft is the same as the input shaft.
The reduction ratio is equal to the reduction ratio on the catalog.

- ② 出力軸固定，減速機箱體外殼輸出的情況：減速機箱體外殼的旋轉方向與輸入軸的旋轉方向相反。減速比等於型錄上的減速比減 1。
The output shaft is fixed, and the housing drive:
The rotation direction of the housing is the opposite to the input shaft.
The reduction ratio is calculated the reduction ratio on the catalog minus 1.

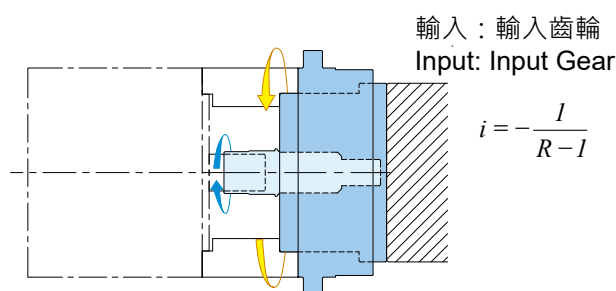
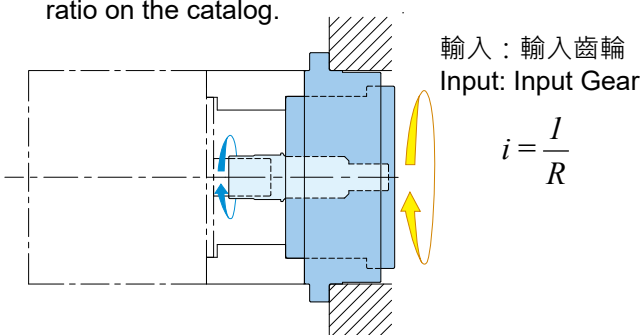

產品樣式選擇 Selection of Type

		入力形式 Input Type			
		E 組件式 Component Type	N 入力法蘭 Motor Flange Type	S 入力軸式 Input Shaft Type	L 入力直交 Right Angle
出力形式 Output Type	RS	RSE	RSN	RSS	
	RD	RDE	RDN	RDS	RDL
	RC 出力中空軸 Hollow Output Shaft	RCE	RCN	RCS	RCL

產品特性 Characteristic

- 高可靠性、高剛度、高精度、大扭矩
 1. 最佳化的擺線齒型設計，扭曲剛度非常大。
 2. 兩個擺線輪設計，多齒嚙合增加強度。
 3. 採用雙支撐的斜角滾珠軸承並加大軸承跨距，增加出力端剛性。
 4. 即使施加高達額定轉矩 5 倍的轉矩時，產品也不會損壞。
 5. 高精密的加工技術，使得產品齒隙小 (<1 arcmin)，運轉效率高。
- 追求簡單使用
 1. 已封入潤滑脂，防護等級 IP65，免更換及保護。
 2. 採用筒夾式的鎖緊機構和及這適用於各廠牌的馬達法蘭，使馬達的安裝非常簡單。

- High reliability, high rigidity, high precision, high torque
 1. The optimized cycloidal tooth design makes it very high twisting stiffness.
 2. Dual cycloidal wheels, multi-toothed meshing for increased strength.
 3. Double-supported angular contact ball bearings are used to increase the bearing span and increase the rigidity of the output end.
 4. Even the torque up to 5 times rated torque, the product will not be damaged.
 5. High-precision machining technology makes the product have small backlash (<1 arcmin) and high operating efficiency.
- Easy installation and maintenance
 1. Grease is sealed, protection class IP65. No need to replace the grease.
 2. The motor flange is ready for each brand and a collet-type locking mechanism makes the installation of motor very easy.

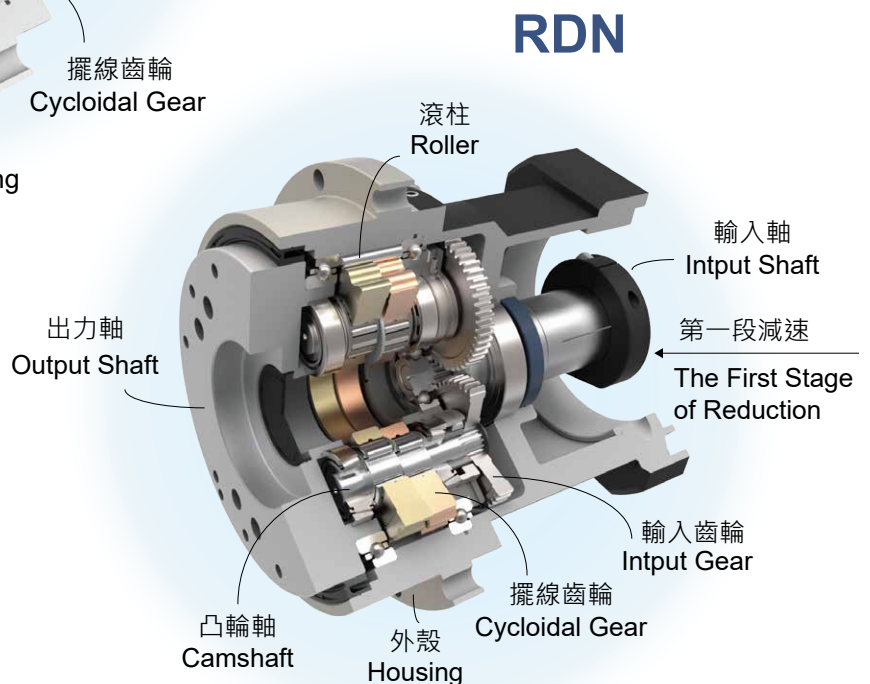
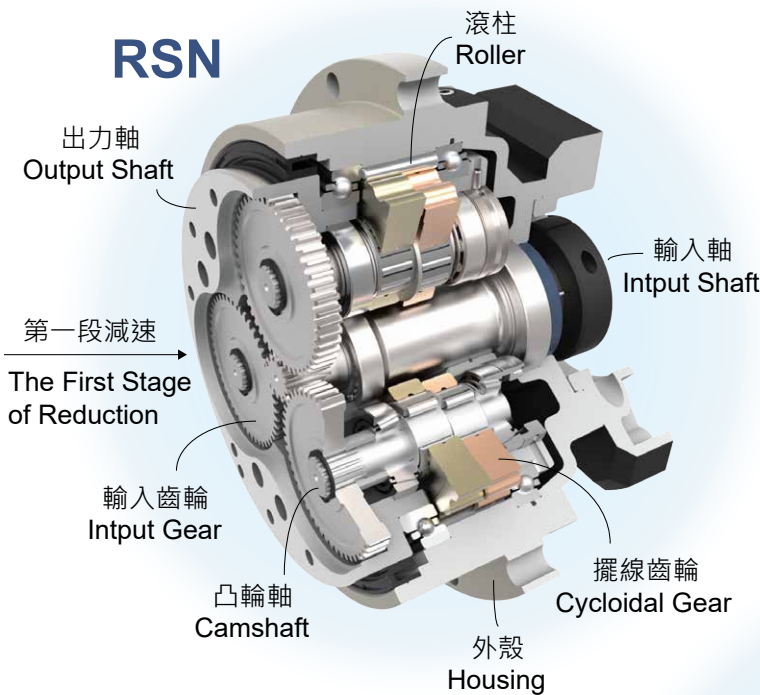

主軸承的能力 Capacity of Main Bearing

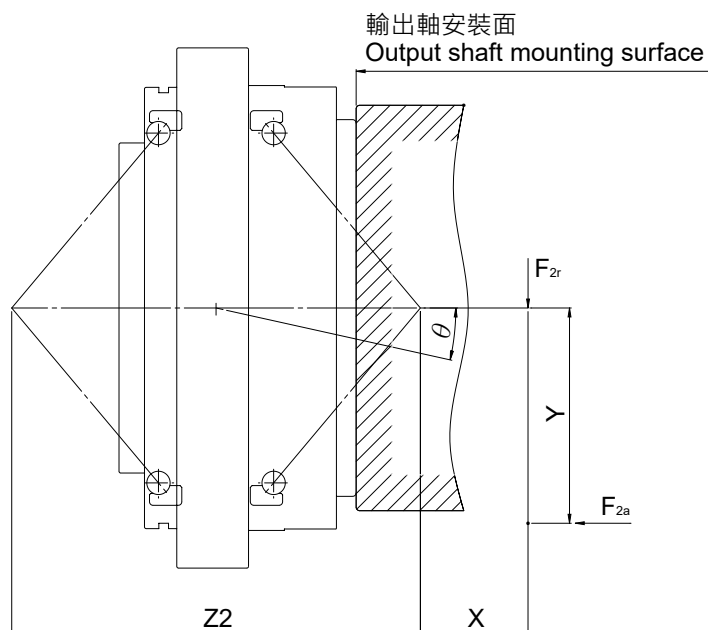

彎矩剛性 Moment Rigidity

$$\theta = \frac{F_{2a} \cdot Y + F_{2r} \cdot \left(X + \frac{Z2}{2}\right)}{Mt \cdot 1000}$$

型號 Model	彎矩剛性 Moment Rigidity	尺寸 Dimension
	Mt Nm/arcmin	Z2 mm
6	108	92
20	335	114
40	843	145
80	1,091	162
110	1,356	172
160	2,780	206
320	4,500	248
450	7,000	286

- θ : 輸出軸的傾斜角度 Deflected Angle of Output Shaft [arcmin]
- Mt : 彎矩剛性 Moment Rigidity [Nm/arcmin]
- $F_{2r}、F_{2a}$: 負荷 Weight [N]
- $X、Y$: 到負荷作用點的距離 Distance to Load Point [mm]

允許彎矩 Allowable Moment

$$M_{2K} \leq \text{允許彎矩值 Allowable Moment}$$

$$M_{2K} = \frac{F_{2a} \cdot Y + F_{2r} \cdot (X + Z2)}{1000}$$

型號 Model	允許彎矩 Allowable Moment Nm
6	200
20	900
40	1,700
80	2,200
110	2,900
160	3,900
320	7,000
450	8,800

- M_{2K} : 負載彎矩 External Moment [Nm]
- $F_{2r}、F_{2a}$: 負荷 Weight [N]
- $X、Y$: 到負荷作用點的距離 Distance to Load Point [mm]

允許彎矩曲線圖 Allowable Moment Curve

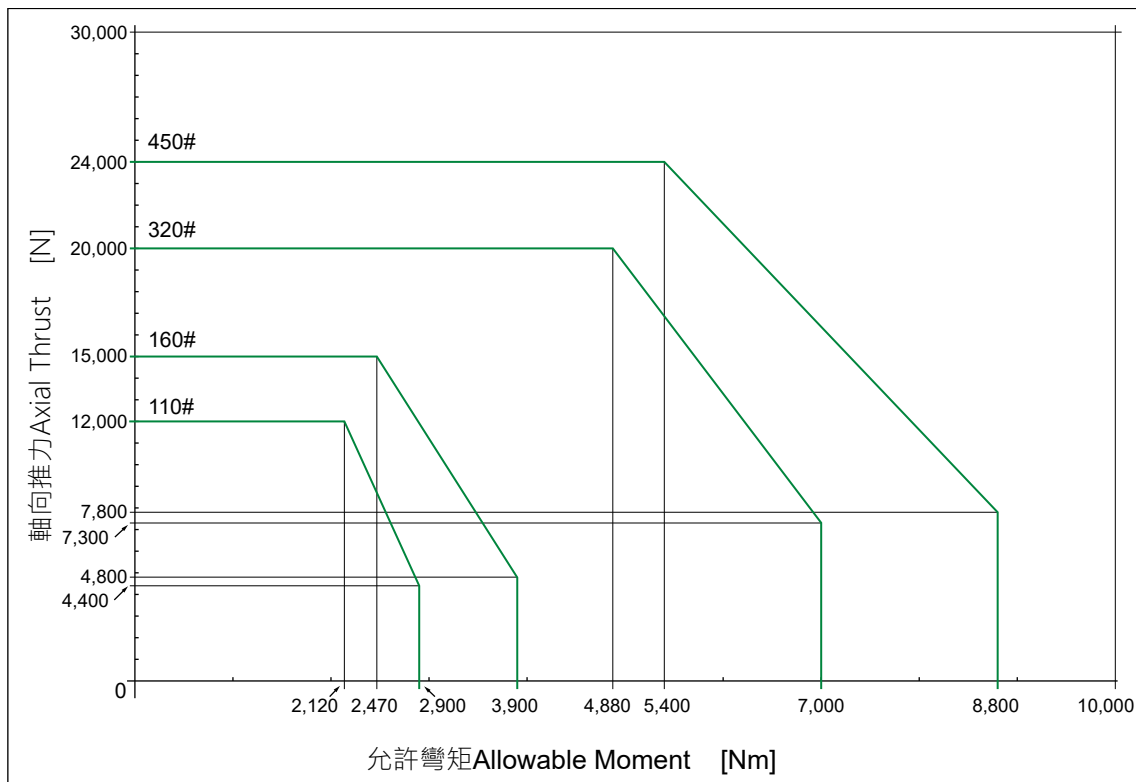
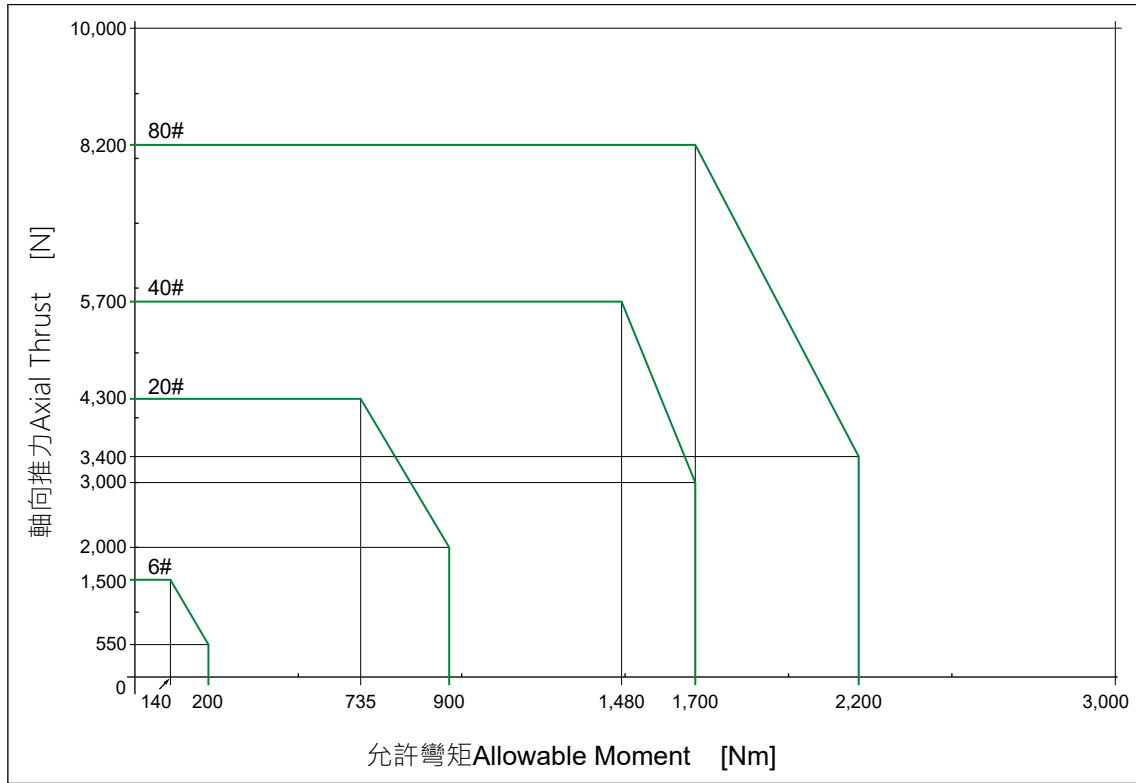



RSE

高精密擺線減速機

MODEL : RSE6

RATIO : 41、61、81、121

Unit: mm

Ratio Code	41、61、81、121
C	#6802
D	Ø15 ^{-0.01} / _{-0.02}
E	13
F	21.5

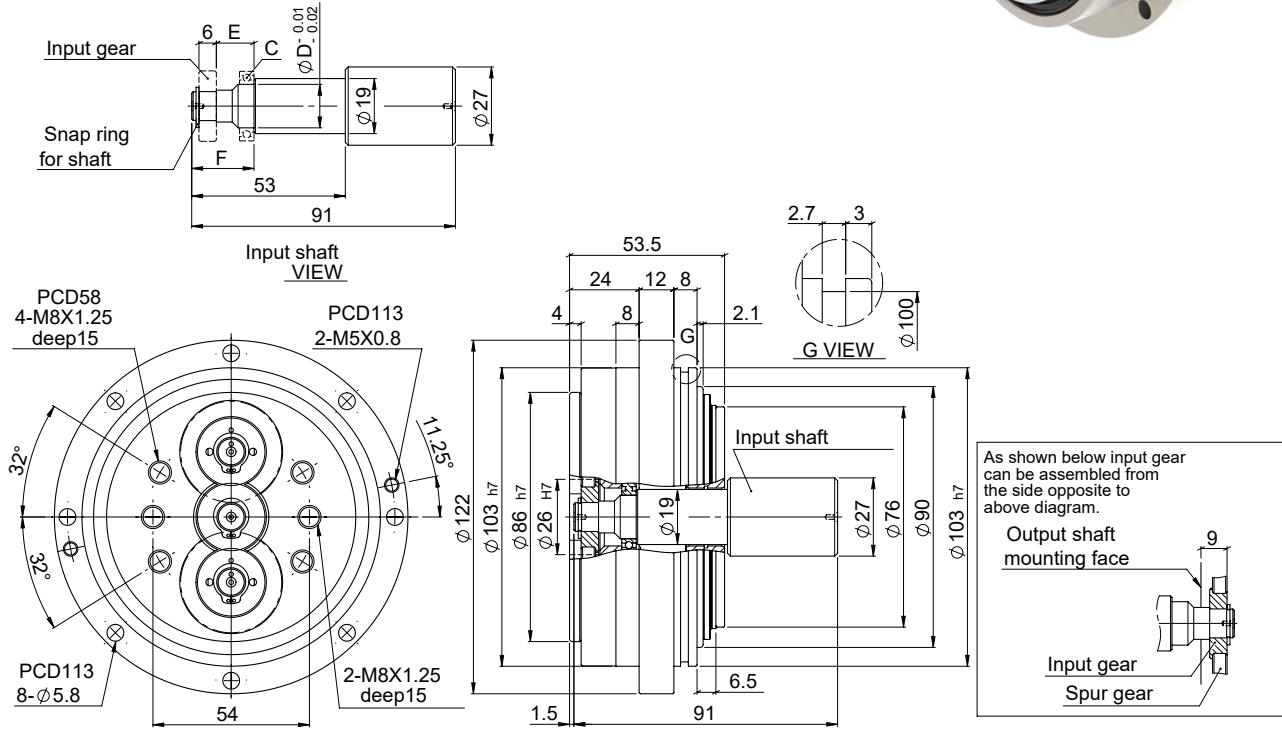

特性 Characteristic	代號	單位 Unit	RSE6
輸出平台支撐軸承 / Output Table Supporting Bearing			斜角滾珠軸承 Angular Contact Ball Bearing
額定輸出扭矩 / Rated Output Torque		Nm	60
最大輸出扭矩 / Max. Output Torque 急停扭矩 / Emergency Stop Torque	T_{2NOT}	Nm	5 倍額定輸出扭矩 5 Time of Rated Output Torque
最大加速力矩 / Max. Acceleration Torque	T_{2B}	Nm	2 倍額定輸出力矩 2 Times of Rated Output Torque
慣性慣量 / Inertia Moment		kg.m ²	0.19 x 10 ⁻⁴
額定出力轉速 / Rated Output Speed		rpm	15
最大輸出轉速 / Max. Output Speed		rpm	55
容許輸入轉速 / Permissible Input Speed		rpm	3,000
背隙 / Backlash Ps	J_i	arcmin	≤ 2
背隙 / Backlash P0	J_i	arcmin	≤ 4
背隙 / Backlash P1	J_i	arcmin	≤ 6
容許徑向力 / Max. Radial Force	F_{2rB}	N	2,100
容許軸向力 / Max. Axial Force	F_{2aB}	N	1,500
額定壽命 / Rated Life	L_H	hr	S5 周期運轉 : >6,000 (S1 連續運轉 : >3,000 hrs) S5 Cycle Operation: >6,000 (S1 Continuous Operation: >3,000 hrs)
扭轉剛性 / Torsional Rigidity		Nm/arcmin	50
效率 / Efficiency	η	%	≥ 85
重量 / Weight		kg	2.8

MODEL : RSE20

RATIO : 41、61、81、121、161

Unit: mm

Ratio Code	41、61、81、121、161
C	#6902
D	Ø15 ^{-0.01} _{-0.02}
E	16.5
F	26

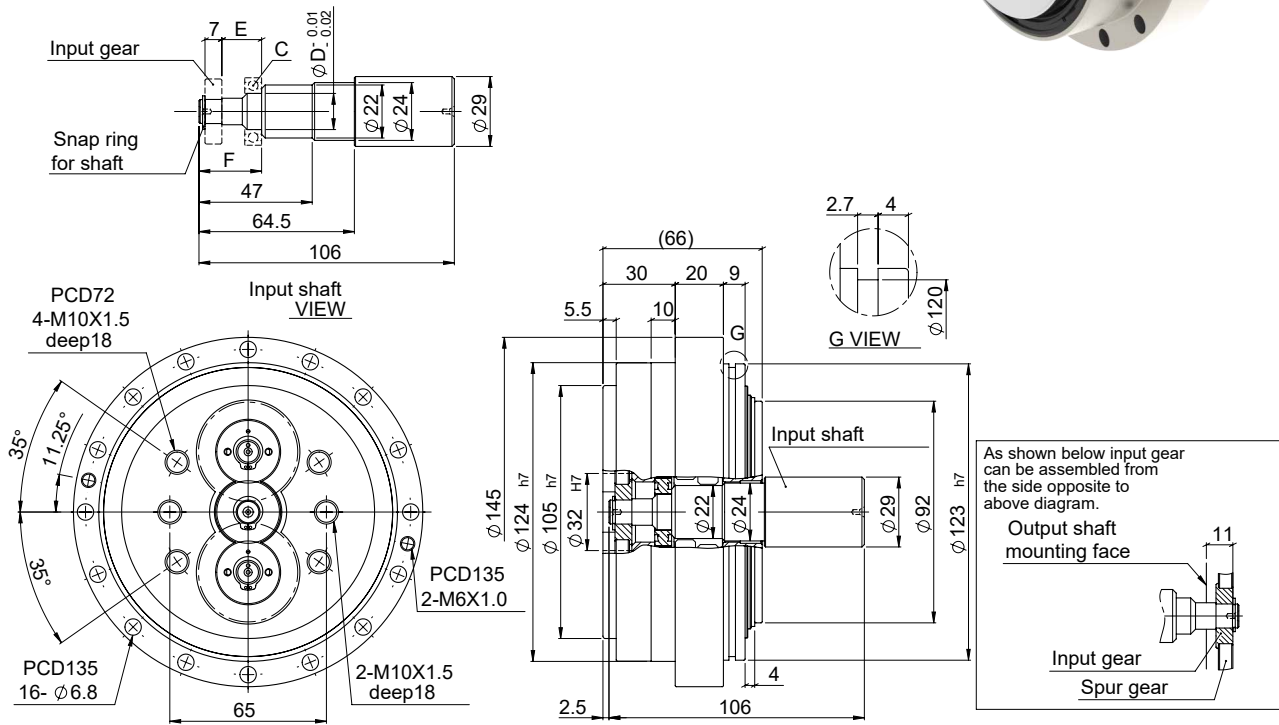

特性 Characteristic	代號	單位 Unit	RSE20
輸出平台支撐軸承 / Output Table Supporting Bearing			斜角滾珠軸承 Angular Contact Ball Bearing
額定輸出扭矩 / Rated Output Torque		Nm	200
最大輸出扭矩 / Max. Output Torque 急停扭矩 / Emergency Stop Torque	T_{2NOT}	Nm	5 倍額定輸出扭矩 5 Time of Rated Output Torque
最大加速力矩 / Max. Acceleration Torque	T_{2B}	Nm	2.5 倍額定輸出力矩 2.5 Times of Rated Output Torque
慣性慣量 / Inertia Moment		kg.m ²	0.31 x 10 ⁻⁴
額定出力轉速 / Rated Output Speed		rpm	15
最大輸出轉速 / Max. Output Speed		rpm	50
容許輸入轉速 / Permissible Input Speed		rpm	3,000
背隙 / Backlash Ps	J_i	arcmin	≤ 1
背隙 / Backlash P0	J_i	arcmin	≤ 3
背隙 / Backlash P1	J_i	arcmin	≤ 5
容許徑向力 / Max. Radial Force	F_{2rB}	N	6,500
容許軸向力 / Max. Axial Force	F_{2aB}	N	4,300
額定壽命 / Rated Life	L_H	hr	S5 周期運轉 : >6,000 (S1 連續運轉 : >3,000 hrs) S5 Cycle Operation: >6,000 (S1 Continuous Operation: >3,000 hrs)
扭轉剛性 / Torsional Rigidity		Nm/arcmin	70
效率 / Efficiency	η	%	≥ 85
重量 / Weight		kg	5.1

MODEL : RSE40

RATIO : 41、61、81、121、161

Unit: mm

Ratio Code	41、61、81、121、161
C	#6904
D	Ø20 ^{-0.01} _{-0.02}
E	20
F	30.5

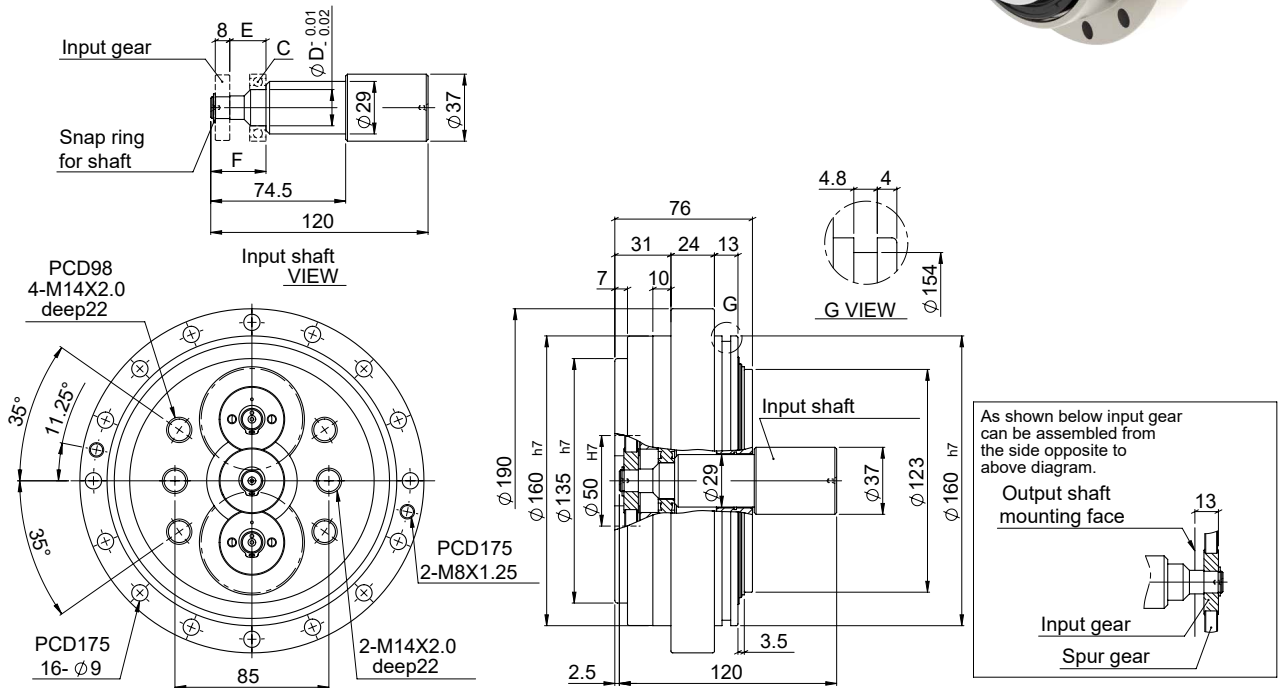

特性 Characteristic	代號	單位 Unit	RSE40
輸出平台支撐軸承 / Output Table Supporting Bearing			斜角滾珠軸承 Angular Contact Ball Bearing
額定輸出扭矩 / Rated Output Torque		Nm	400
最大輸出扭矩 / Max. Output Torque 急停扭矩 / Emergency Stop Torque	T_{2NOT}	Nm	5 倍額定輸出扭矩 5 Time of Rated Output Torque
最大加速力矩 / Max. Acceleration Torque	T_{2B}	Nm	2.5 倍額定輸出力矩 2.5 Times of Rated Output Torque
慣性慣量 / Inertia Moment		kg.m ²	0.91 x 10 ⁻⁴
額定出力轉速 / Rated Output Speed		rpm	15
最大輸出轉速 / Max. Output Speed		rpm	45
容許輸入轉速 / Permissible Input Speed		rpm	3,000
背隙 / Backlash Ps	J_i	arcmin	≤ 1
背隙 / Backlash P0	J_i	arcmin	≤ 3
背隙 / Backlash P1	J_i	arcmin	≤ 5
容許徑向力 / Max. Radial Force	F_{2rB}	N	8,600
容許軸向力 / Max. Axial Force	F_{2aB}	N	5,700
額定壽命 / Rated Life	L_H	hr	S5 周期運轉 : >6,000 (S1 連續運轉 : >3,000 hrs) S5 Cycle Operation: >6,000 (S1 Continuous Operation: >3,000 hrs)
扭轉剛性 / Torsional Rigidity		Nm/arcmin	100
效率 / Efficiency	η	%	≥ 85
重量 / Weight		kg	9.7

MODEL : RSE80

RATIO : 45、66、81、101、171

Unit: mm

Ratio Code	45、66、81、171	101
C	#6004	#6905
D	Ø20 ^{-0.01/-0.02}	Ø25 ^{-0.01/-0.02}
E	21	18
F	35.5	32.5

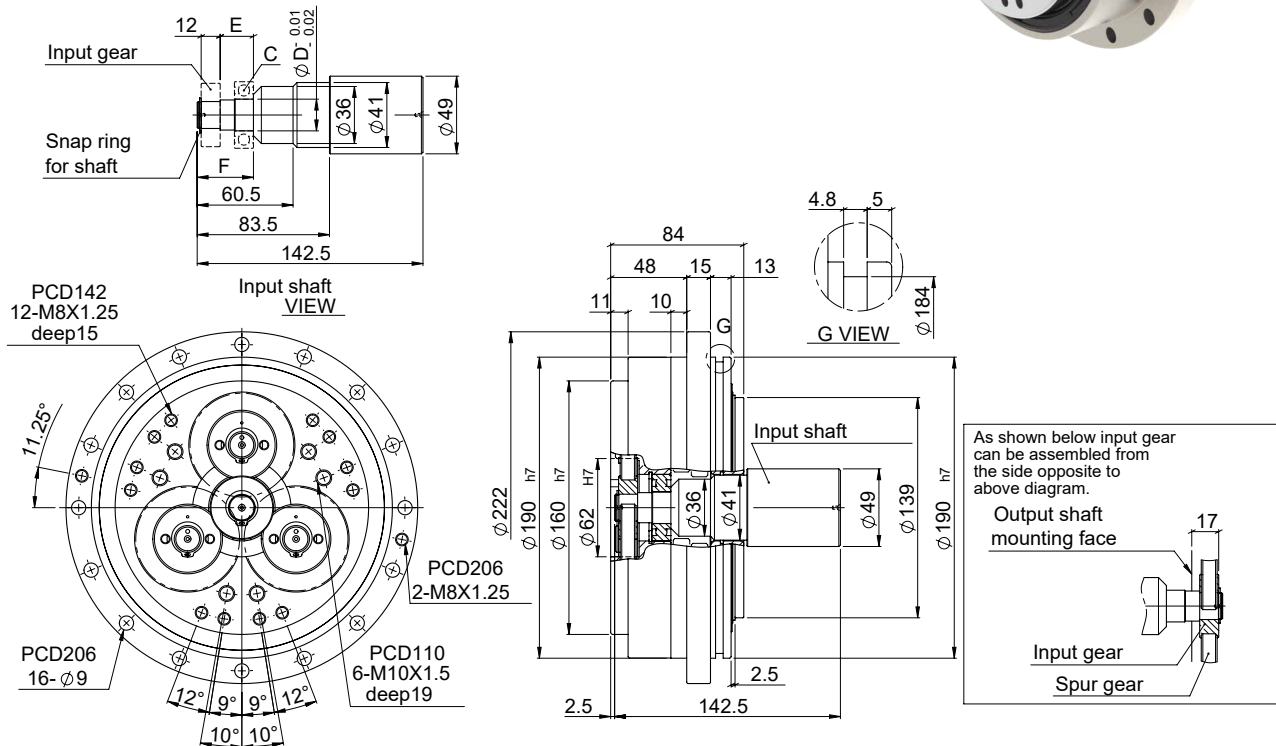

特性 Characteristic	代號	單位 Unit	RSE80
輸出平台支撐軸承 / Output Table Supporting Bearing			斜角滾珠軸承 Angular Contact Ball Bearing
額定輸出扭矩 / Rated Output Torque		Nm	800
最大輸出扭矩 / Max. Output Torque 急停扭矩 / Emergency Stop Torque	T_{2NOT}	Nm	5 倍額定輸出扭矩 5 Time of Rated Output Torque
最大加速力矩 / Max. Acceleration Torque	T_{2B}	Nm	2.5 倍額定輸出力矩 2.5 Times of Rated Output Torque
慣性慣量 / Inertia Moment		kg.m ²	3.43×10^{-4}
額定出力轉速 / Rated Output Speed		rpm	15
最大輸出轉速 / Max. Output Speed		rpm	42
容許輸入轉速 / Permissible Input Speed		rpm	3,000
背隙 / Backlash Ps	J_i	arcmin	≤ 1
背隙 / Backlash P0	J_i	arcmin	≤ 3
背隙 / Backlash P1	J_i	arcmin	≤ 5
容許徑向力 / Max. Radial Force	F_{2rB}	N	12,500
容許軸向力 / Max. Axial Force	F_{2aB}	N	8,200
額定壽命 / Rated Life	L_H	hr	S5 周期運轉 : >6,000 (S1 連續運轉 : >3,000 hrs) S5 Cycle Operation: >6,000 (S1 Continuous Operation: >3,000 hrs)
扭轉剛性 / Torsional Rigidity		Nm/arcmin	150
效率 / Efficiency	η	%	≥ 85
重量 / Weight		kg	15.5

MODEL : RSE110

RATIO : 41、61、81、121、161

Unit: mm

Ratio Code	41、61、81、161	121
C	#6005	#6906
D	Ø25 ^{-0.01} _{-0.02}	Ø30 ^{-0.01} _{-0.02}
E	24.5	21.5
F	39	36

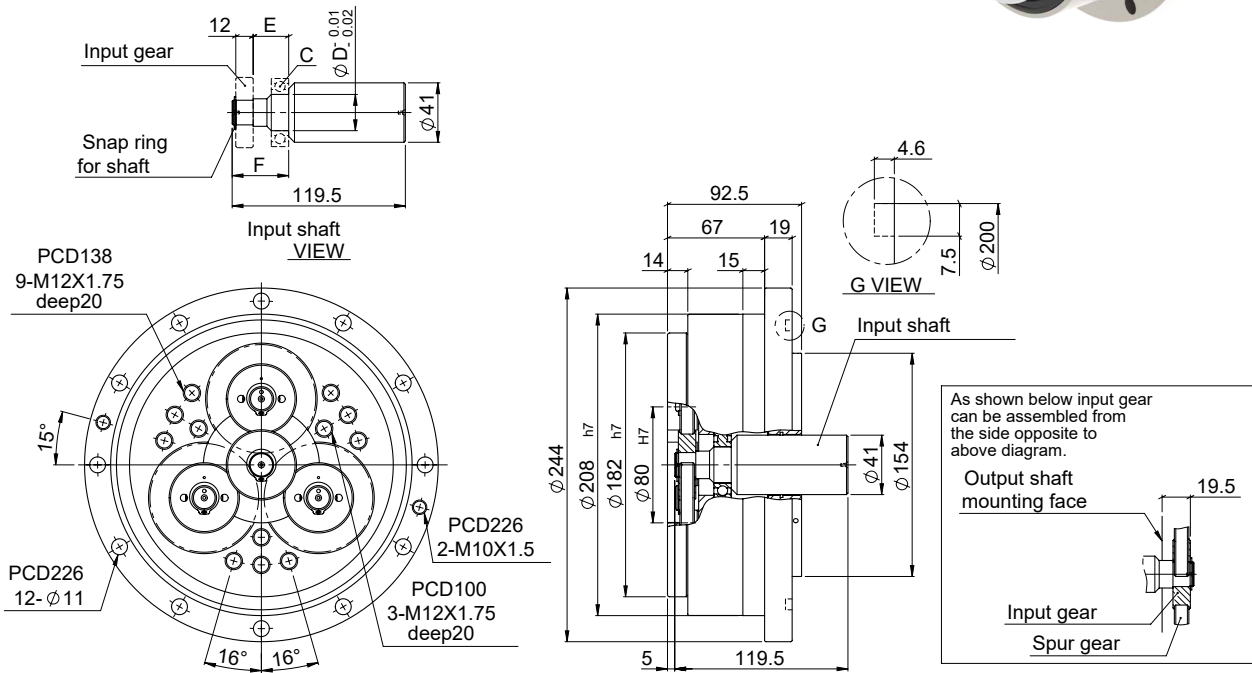

特性 Characteristic	代號	單位 Unit	RSE110
輸出平台支撐軸承 / Output Table Supporting Bearing			斜角滾珠軸承 Angular Contact Ball Bearing
額定輸出扭矩 / Rated Output Torque		Nm	1,100
最大輸出扭矩 / Max. Output Torque 急停扭矩 / Emergency Stop Torque	T_{2NOT}	Nm	5 倍額定輸出扭矩 5 Time of Rated Output Torque
最大加速力矩 / Max. Acceleration Torque	T_{2B}	Nm	2.5 倍額定輸出力矩 2.5 Times of Rated Output Torque
慣性慣量 / Inertia Moment		kg.m ²	1.78 x 10 ⁻⁴
額定出力轉速 / Rated Output Speed		rpm	15
最大輸出轉速 / Max. Output Speed		rpm	35
容許輸入轉速 / Permissible Input Speed		rpm	3,000
背隙 / Backlash Ps	J_i	arcmin	≤ 1
背隙 / Backlash P0	J_i	arcmin	≤ 3
背隙 / Backlash P1	J_i	arcmin	≤ 5
容許徑向力 / Max. Radial Force	F_{2rB}	N	16,000
容許軸向力 / Max. Axial Force	F_{2aB}	N	12,000
額定壽命 / Rated Life	L_H	hr	S5 周期運轉 : >6,000 (S1 連續運轉 : >3,000 hrs) S5 Cycle Operation: >6,000 (S1 Continuous Operation: >3,000 hrs)
扭轉剛性 / Torsional Rigidity		Nm/arcmin	210
效率 / Efficiency	η	%	≥ 85
重量 / Weight		kg	20.5

MODEL : RSE160

RATIO : 41、61、81、121、161

Unit: mm

Ratio Code	41、61、81、121	121
C	#6006	#6907
D	Ø30 ^{-0.01/-0.02}	Ø35 ^{-0.01/-0.02}
E	26.5	23.5
F	43.5	40.5

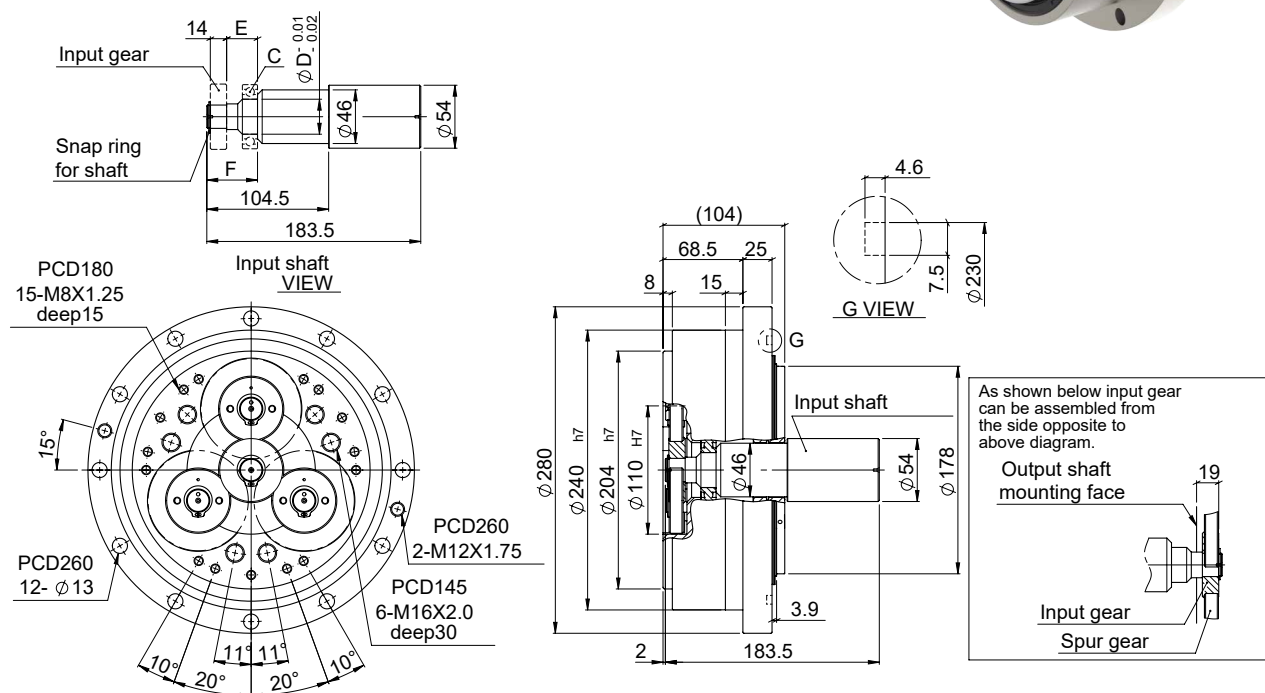

特性 Characteristic	代號	單位 Unit	RSE160
輸出平台支撐軸承 / Output Table Supporting Bearing			斜角滾珠軸承 Angular Contact Ball Bearing
額定輸出扭矩 / Rated Output Torque		Nm	1,600
最大輸出扭矩 / Max. Output Torque 急停扭矩 / Emergency Stop Torque	T_{2NOT}	Nm	5 倍額定輸出扭矩 5 Time of Rated Output Torque
最大加速力矩 / Max. Acceleration Torque	T_{2B}	Nm	2.5 倍額定輸出力矩 2.5 Times of Rated Output Torque
慣性慣量 / Inertia Moment		kg.m ²	7.37×10^{-4}
額定出力轉速 / Rated Output Speed		rpm	15
最大輸出轉速 / Max. Output Speed		rpm	27
容許輸入轉速 / Permissible Input Speed		rpm	3,000
背隙 / Backlash Ps	J_i	arcmin	≤ 1
背隙 / Backlash P0	J_i	arcmin	≤ 3
背隙 / Backlash P1	J_i	arcmin	≤ 5
容許徑向力 / Max. Radial Force	F_{2rB}	N	19,000
容許軸向力 / Max. Axial Force	F_{2aB}	N	15,000
額定壽命 / Rated Life	L_H	hr	S5 周期運轉 : >6,000 (S1 連續運轉 : >3,000 hrs) S5 Cycle Operation: >6,000 (S1 Continuous Operation: >3,000 hrs)
扭轉剛性 / Torsional Rigidity		Nm/arcmin	300
效率 / Efficiency	η	%	≥ 85
重量 / Weight		kg	31.7

MODEL : RSE320

RATIO : 41、61、81、121、161

Unit: mm

Ratio Code	41、61、81、121、161
C	#6007
D	Ø35 ^{-0.01} _{-0.02}
E	32
F	51

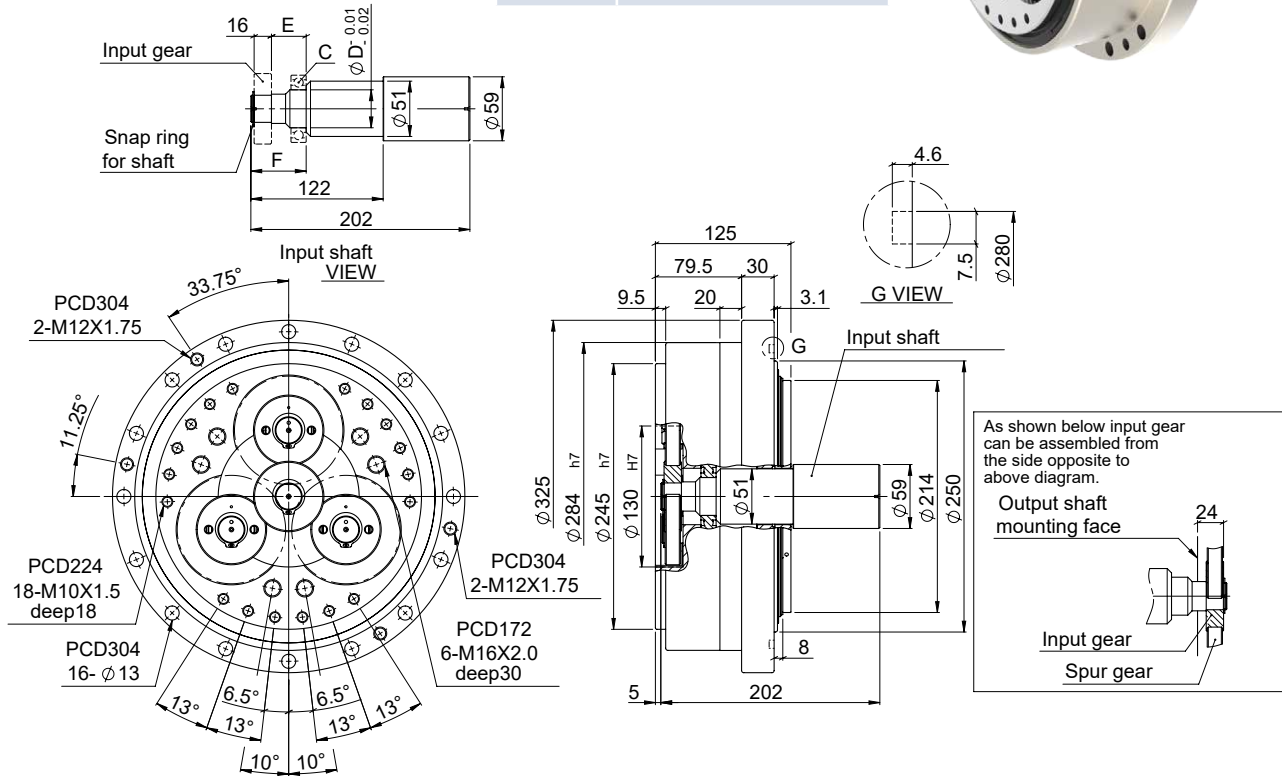

特性 Characteristic	代號	單位 Unit	RSE320
輸出平台支撐軸承 / Output Table Supporting Bearing			斜角滾珠軸承 Angular Contact Ball Bearing
額定輸出扭矩 / Rated Output Torque		Nm	3,200
最大輸出扭矩 / Max. Output Torque 急停扭矩 / Emergency Stop Torque	T_{2NOT}	Nm	5 倍額定輸出扭矩 5 Time of Rated Output Torque
最大加速力矩 / Max. Acceleration Torque	T_{2B}	Nm	2.5 倍額定輸出力矩 2.5 Times of Rated Output Torque
慣性慣量 / Inertia Moment		kg.m ²	11.42 x 10 ⁻⁴
額定出力轉速 / Rated Output Speed		rpm	15
最大輸出轉速 / Max. Output Speed		rpm	21
容許輸入轉速 / Permissible Input Speed		rpm	3,000
背隙 / Backlash Ps	J_i	arcmin	≤ 1
背隙 / Backlash P0	J_i	arcmin	≤ 3
背隙 / Backlash P1	J_i	arcmin	≤ 5
容許徑向力 / Max. Radial Force	F_{2rB}	N	25,300
容許軸向力 / Max. Axial Force	F_{2aB}	N	20,000
額定壽命 / Rated Life	L_H	hr	S5 周期運轉 : >6,000 (S1 連續運轉 : >3,000 hrs) S5 Cycle Operation: >6,000 (S1 Continuous Operation: >3,000 hrs)
扭轉剛性 / Torsional Rigidity		Nm/arcmin	980
效率 / Efficiency	η	%	≥ 85
重量 / Weight		kg	50.8

MODEL : RSE450

RATIO : 45、66、81、101、171

Unit: mm

Ratio Code	45、66、81、171	101
C	#6008	#6909
D	Ø40 ^{-0.01} _{-0.02}	Ø45 ^{-0.01} _{-0.02}
E	34	31
F	53.5	50.5

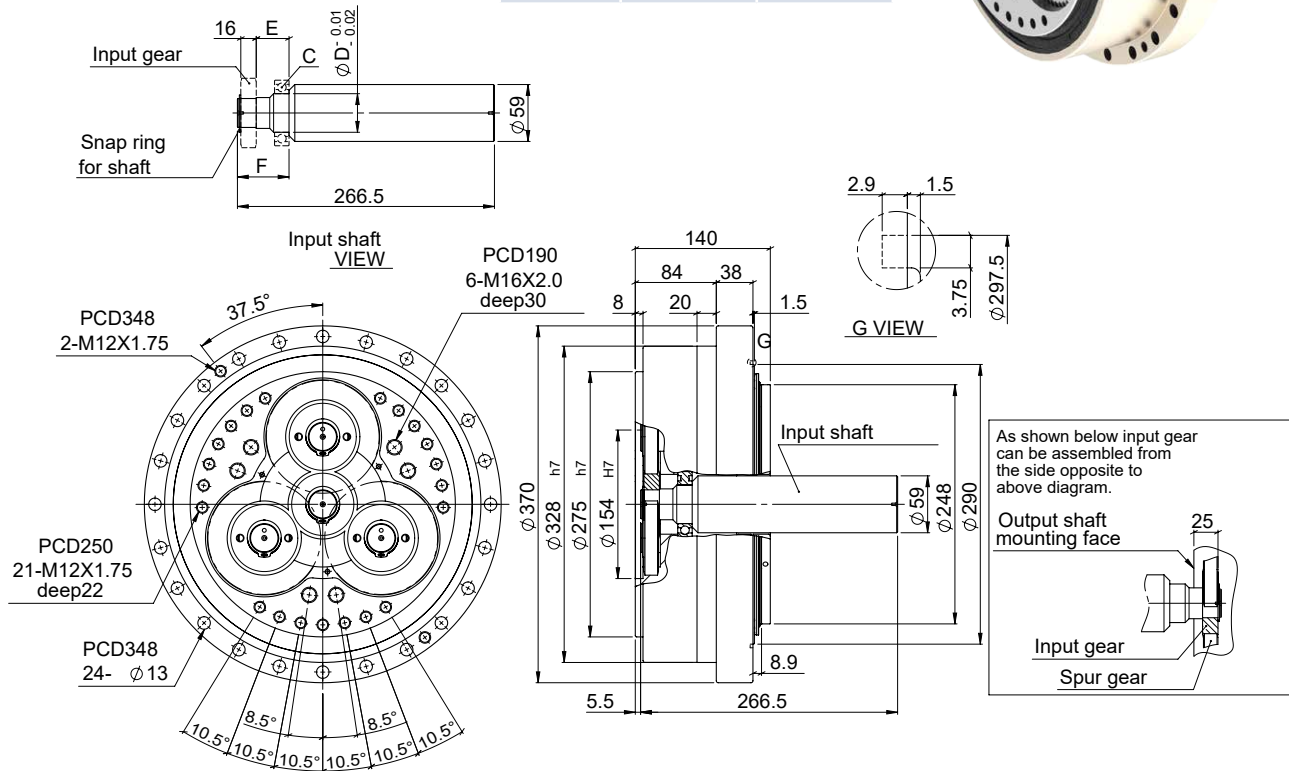

特性 Characteristic	代號	單位 Unit	RSE450
輸出平台支撐軸承 / Output Table Supporting Bearing			斜角滾珠軸承 Angular Contact Ball Bearing
額定輸出扭矩 / Rated Output Torque		Nm	4,500
最大輸出扭矩 / Max. Output Torque 急停扭矩 / Emergency Stop Torque	T_{2NOT}	Nm	5 倍額定輸出扭矩 5 Time of Rated Output Torque
最大加速力矩 / Max. Acceleration Torque	T_{2B}	Nm	2.5 倍額定輸出力矩 2.5 Times of Rated Output Torque
慣性慣量 / Inertia Moment		kg.m ²	20.27 x 10 ⁻⁴
額定出力轉速 / Rated Output Speed		rpm	15
最大輸出轉速 / Max. Output Speed		rpm	21
容許輸入轉速 / Permissible Input Speed		rpm	3,000
背隙 / Backlash Ps	J_i	arcmin	≤ 1
背隙 / Backlash P0	J_i	arcmin	≤ 3
背隙 / Backlash P1	J_i	arcmin	≤ 5
容許徑向力 / Max. Radial Force	F_{2rB}	N	30,000
容許軸向力 / Max. Axial Force	F_{2aB}	N	24,000
額定壽命 / Rated Life	L_H	hr	S5 周期運轉 : >6,000 (S1 連續運轉 : >3,000 hrs) S5 Cycle Operation: >6,000 (S1 Continuous Operation: >3,000 hrs)
扭轉剛性 / Torsional Rigidity		Nm/arcmin	7,400
效率 / Efficiency	η	%	≥ 85
重量 / Weight		kg	

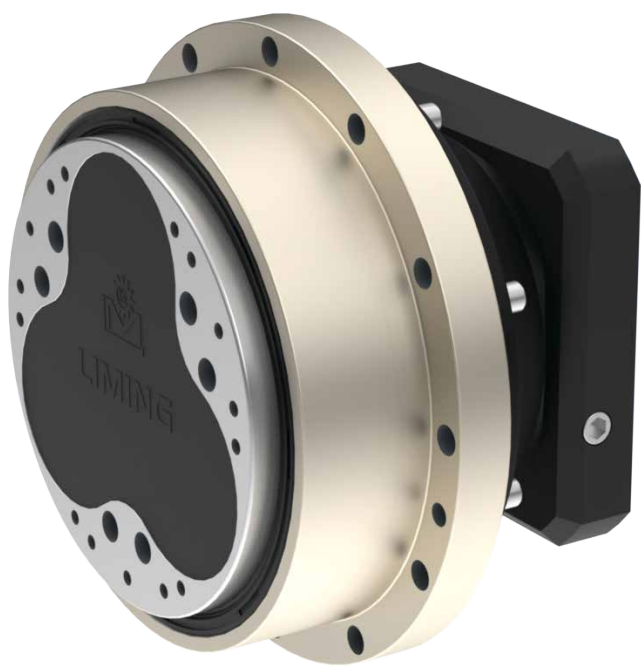

RSN

高精度擺線減速機

MODEL : RSN6

RATIO : 41、61、81、121

Unit: mm

Model Code	RSN6
A1	70、75、90
A2	M4、M5、M6
A3	50、60、70
A4	64、70、80

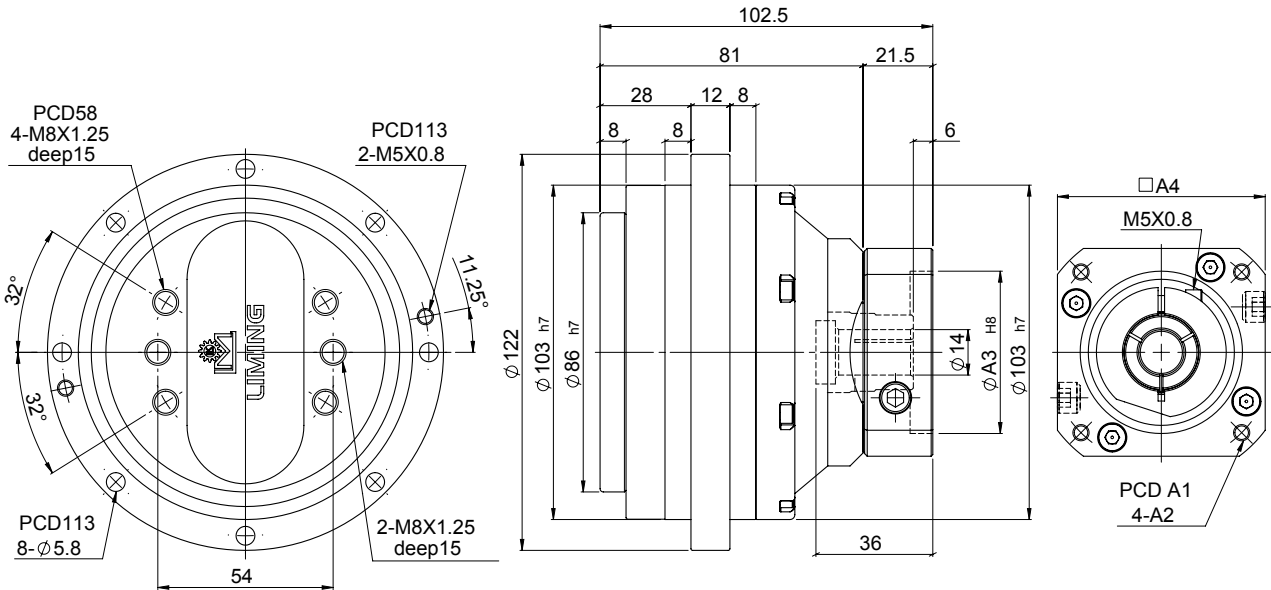

特性 Characteristic	代號	單位 Unit	RSN6
輸出平台支撐軸承 / Output Table Supporting Bearing			斜角滾珠軸承 Angular Contact Ball Bearing
額定輸出扭矩 / Rated Output Torque		Nm	60
最大輸出扭矩 / Max. Output Torque 急停扭矩 / Emergency Stop Torque	T_{2NOT}	Nm	5 倍額定輸出扭矩 5 Time of Rated Output Torque
最大加速力矩 / Max. Acceleration Torque	T_{2B}	Nm	2 倍額定輸出力矩 2 Times of Rated Output Torque
慣性慣量 / Inertia Moment		kg.m ²	0.31 x 10 ⁻⁴
額定出力轉速 / Rated Output Speed		rpm	15
最大輸出轉速 / Max. Output Speed		rpm	55
容許輸入轉速 / Permissible Input Speed		rpm	3,000
背隙 / Backlash Ps	J_i	arcmin	≤ 2
背隙 / Backlash P0	J_i	arcmin	≤ 4
背隙 / Backlash P1	J_i	arcmin	≤ 6
容許徑向力 / Max. Radial Force	F_{2rB}	N	2,100
容許軸向力 / Max. Axial Force	F_{2aB}	N	1,500
額定壽命 / Rated Life	L_H	hr	S5 周期運轉 : >6,000 (S1 連續運轉 : >3,000 hrs) S5 Cycle Operation: >6,000 (S1 Continuous Operation: >3,000 hrs)
扭轉剛性 / Torsional Rigidity		Nm/arcmin	50
效率 / Efficiency	η	%	≥ 85
重量 / Weight		kg	3.3

MODEL : RSN20

RATIO : 41、61、81、121、161

Unit: mm

Model Code	RSN20
A1	70、75、90
A2	M4、M5、M6
A3	50、60、70
A4	64、70、80
A5	14、19
A6	36、46

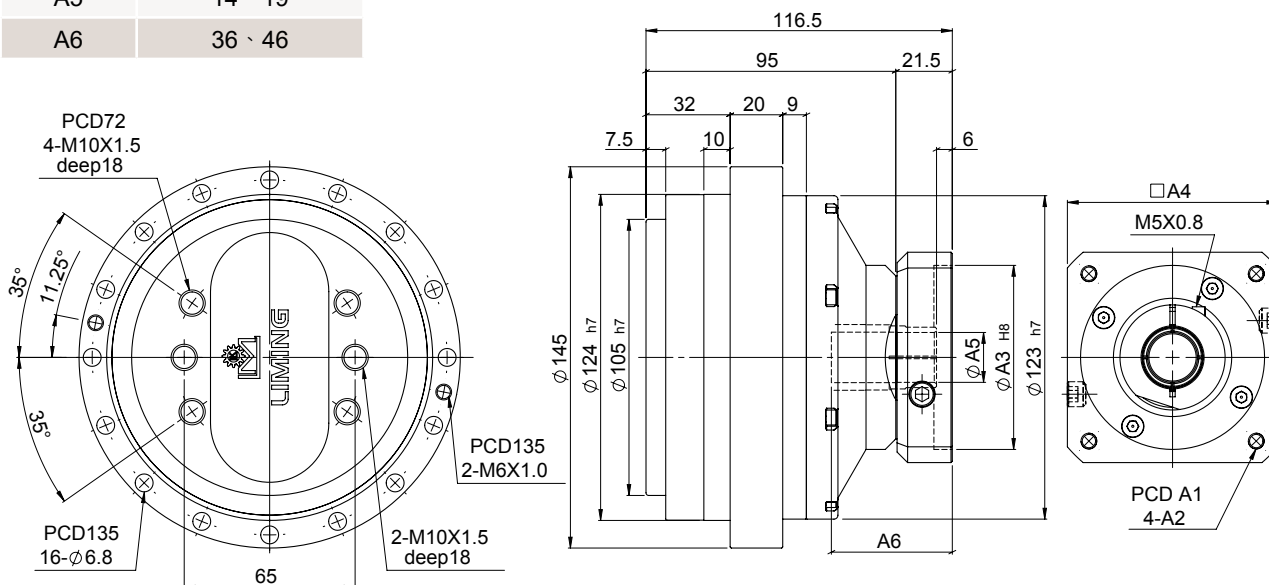

特性 Characteristic	代號	單位 Unit	RSN20
輸出平台支撐軸承 / Output Table Supporting Bearing			斜角滾珠軸承 Angular Contact Ball Bearing
額定輸出扭矩 / Rated Output Torque		Nm	200
最大輸出扭矩 / Max. Output Torque 急停扭矩 / Emergency Stop Torque	T_{2NOT}	Nm	5 倍額定輸出扭矩 5 Time of Rated Output Torque
最大加速力矩 / Max. Acceleration Torque	T_{2B}	Nm	2.5 倍額定輸出力矩 2.5 Times of Rated Output Torque
慣性慣量 / Inertia Moment		kg.m ²	0.34 x 10 ⁻⁴
額定出力轉速 / Rated Output Speed		rpm	15
最大輸出轉速 / Max. Output Speed		rpm	50
容許輸入轉速 / Permissible Input Speed		rpm	3,000
背隙 / Backlash Ps	J_i	arcmin	≤ 1
背隙 / Backlash P0	J_i	arcmin	≤ 3
背隙 / Backlash P1	J_i	arcmin	≤ 5
容許徑向力 / Max. Radial Force	F_{2rB}	N	6,500
容許軸向力 / Max. Axial Force	F_{2aB}	N	4,300
額定壽命 / Rated Life	L_H	hr	S5 周期運轉 : >6,000 (S1 連續運轉 : >3,000 hrs) S5 Cycle Operation: >6,000 (S1 Continuous Operation: >3,000 hrs)
扭轉剛性 / Torsional Rigidity		Nm/arcmin	70
效率 / Efficiency	η	%	≥ 85
重量 / Weight		kg	5.8

MODEL : RSN80

RATIO : 45、66、81、101、171

Unit: mm

Model Code	RSN80
A1	115、145、165
A2	M6、M8、M10
A3	95、110、130
A4	122、130、150
A5	24、28
A6	27.3、31.3

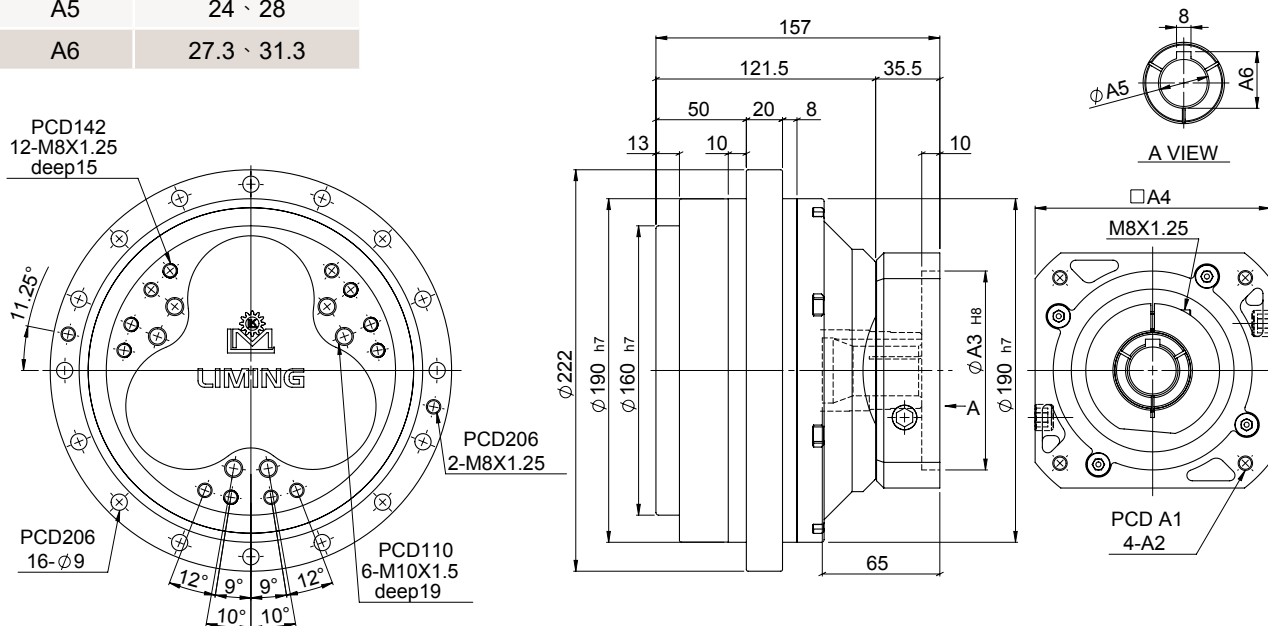
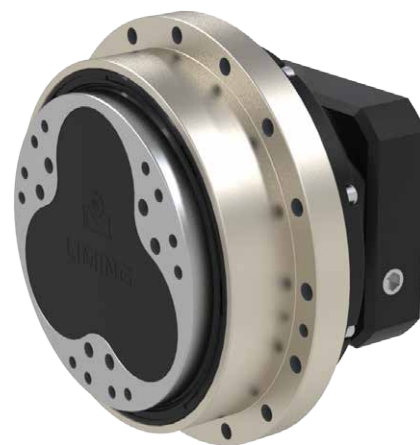

特性 Characteristic	代號	單位 Unit	RSN80
輸出平台支撐軸承 / Output Table Supporting Bearing			斜角滾珠軸承 Angular Contact Ball Bearing
額定輸出扭矩 / Rated Output Torque		Nm	800
最大輸出扭矩 / Max. Output Torque 急停扭矩 / Emergency Stop Torque	T_{2NOT}	Nm	5 倍額定輸出扭矩 5 Time of Rated Output Torque
最大加速力矩 / Max. Acceleration Torque	T_{2B}	Nm	2.5 倍額定輸出力矩 2.5 Times of Rated Output Torque
慣性慣量 / Inertia Moment		kg.m ²	5.49×10^{-4}
額定出力轉速 / Rated Output Speed		rpm	15
最大輸出轉速 / Max. Output Speed		rpm	42
容許輸入轉速 / Permissible Input Speed		rpm	3,000
背隙 / Backlash Ps	J_i	arcmin	≤ 1
背隙 / Backlash P0	J_i	arcmin	≤ 3
背隙 / Backlash P1	J_i	arcmin	≤ 5
容許徑向力 / Max. Radial Force	F_{2rB}	N	12,500
容許軸向力 / Max. Axial Force	F_{2aB}	N	8,200
額定壽命 / Rated Life	L_H	hr	S5 周期運轉 : >6,000 (S1 連續運轉 : >3,000 hrs) S5 Cycle Operation: >6,000 (S1 Continuous Operation: >3,000 hrs)
扭轉剛性 / Torsional Rigidity		Nm/arcmin	150
效率 / Efficiency	η	%	≥ 85
重量 / Weight		kg	17.7

MODEL : RSN110

RATIO : 41、61、81、121、161

Unit: mm

Model Code	RSN110
A1	115、145、165
A2	M6、M8、M10
A3	95、110、130
A4	122、130、150
A5	28、32
A6	8、10
A7	31.3、35.3
A8	72、85

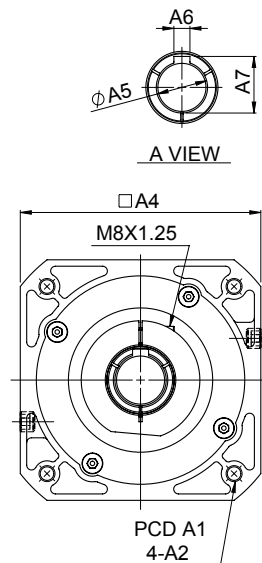
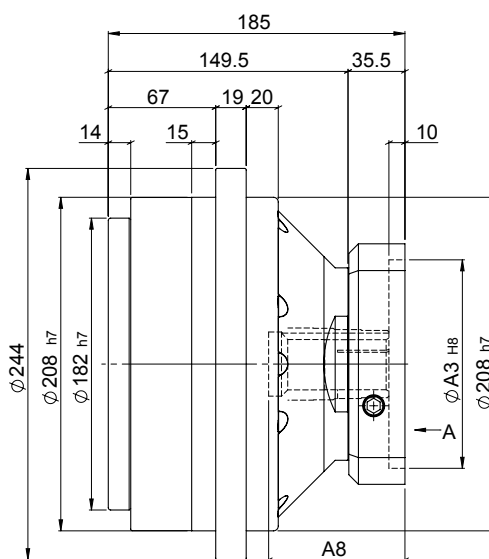
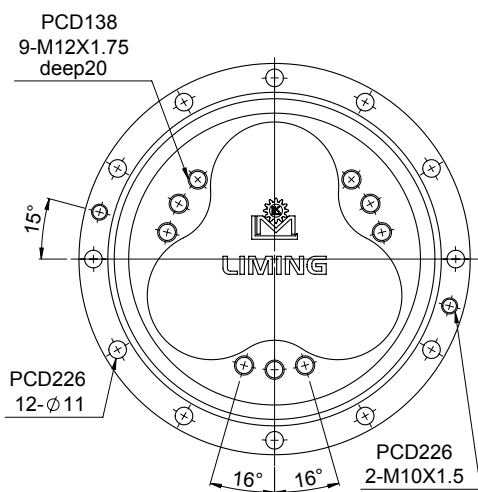
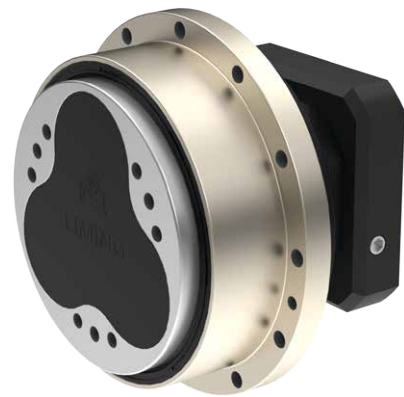

特性 Characteristic	代號	單位 Unit	RSN110
輸出平台支撐軸承 / Output Table Supporting Bearing			斜角滾珠軸承 Angular Contact Ball Bearing
額定輸出扭矩 / Rated Output Torque		Nm	1,100
最大輸出扭矩 / Max. Output Torque 急停扭矩 / Emergency Stop Torque	T_{2NOT}	Nm	5 倍額定輸出扭矩 5 Time of Rated Output Torque
最大加速力矩 / Max. Acceleration Torque	T_{2B}	Nm	2.5 倍額定輸出力矩 2.5 Times of Rated Output Torque
慣性慣量 / Inertia Moment		kg.m ²	5.99×10^{-4}
額定出力轉速 / Rated Output Speed		rpm	15
最大輸出轉速 / Max. Output Speed		rpm	35
容許輸入轉速 / Permissible Input Speed		rpm	3,000
背隙 / Backlash Ps	J_i	arcmin	≤ 1
背隙 / Backlash P0	J_i	arcmin	≤ 3
背隙 / Backlash P1	J_i	arcmin	≤ 5
容許徑向力 / Max. Radial Force	F_{2rB}	N	16,000
容許軸向力 / Max. Axial Force	F_{2aB}	N	12,000
額定壽命 / Rated Life	L_H	hr	S5 周期運轉 : >6,000 (S1 連續運轉 : >3,000 hrs) S5 Cycle Operation: >6,000 (S1 Continuous Operation: >3,000 hrs)
扭轉剛性 / Torsional Rigidity		Nm/arcmin	210
效率 / Efficiency	η	%	≥ 85
重量 / Weight		kg	23.1

MODEL : RSN160

RATIO : 41、61、81、121、161

Unit: mm

Model Code	RSN160
A1	145、165、200
A2	M8、M10、M12
A3	110、130、180
A4	146、150、190
A5	32、35
A6	35.3、38.3

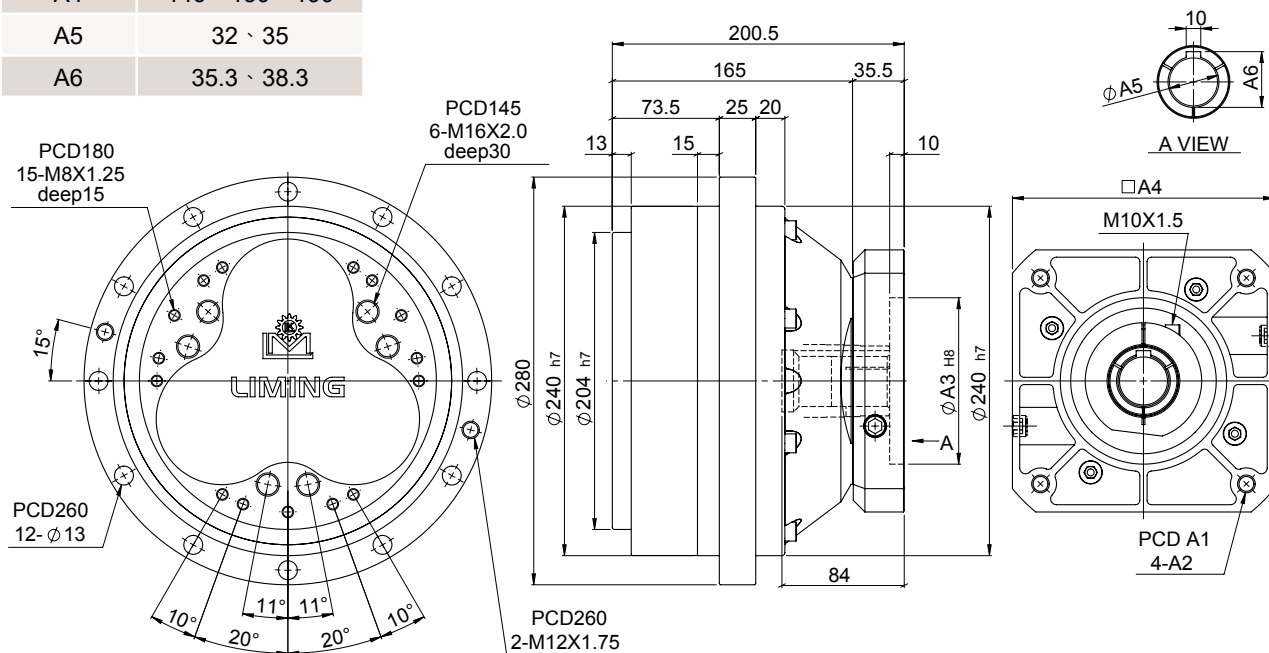

特性 Characteristic	代號	單位 Unit	RSN160
輸出平台支撐軸承 / Output Table Supporting Bearing			斜角滾珠軸承 Angular Contact Ball Bearing
額定輸出扭矩 / Rated Output Torque		Nm	1,600
最大輸出扭矩 / Max. Output Torque 急停扭矩 / Emergency Stop Torque	T_{2NOT}	Nm	5 倍額定輸出扭矩 5 Time of Rated Output Torque
最大加速力矩 / Max. Acceleration Torque	T_{2B}	Nm	2.5 倍額定輸出力矩 2.5 Times of Rated Output Torque
慣性慣量 / Inertia Moment		kg.m ²	10.12 x 10 ⁻⁴
額定出力轉速 / Rated Output Speed		rpm	15
最大輸出轉速 / Max. Output Speed		rpm	27
容許輸入轉速 / Permissible Input Speed		rpm	3,000
背隙 / Backlash Ps	J_i	arcmin	≤ 1
背隙 / Backlash P0	J_i	arcmin	≤ 3
背隙 / Backlash P1	J_i	arcmin	≤ 5
容許徑向力 / Max. Radial Force	F_{2rB}	N	19,000
容許軸向力 / Max. Axial Force	F_{2aB}	N	15,000
額定壽命 / Rated Life	L_H	hr	S5 周期運轉 : >6,000 (S1 連續運轉 : >3,000 hrs) S5 Cycle Operation: >6,000 (S1 Continuous Operation: >3,000 hrs)
扭轉剛性 / Torsional Rigidity		Nm/arcmin	300
效率 / Efficiency	η	%	≥ 85
重量 / Weight		kg	36.4

MODEL : RSN320

RATIO : 41、61、81、121、161

Unit: mm

Model Code	RSN320
A1	165、200、215
A2	M8、M10、M12
A3	114.3、130、180
A4	182、200
A5	35、38
A6	38.3、41.3

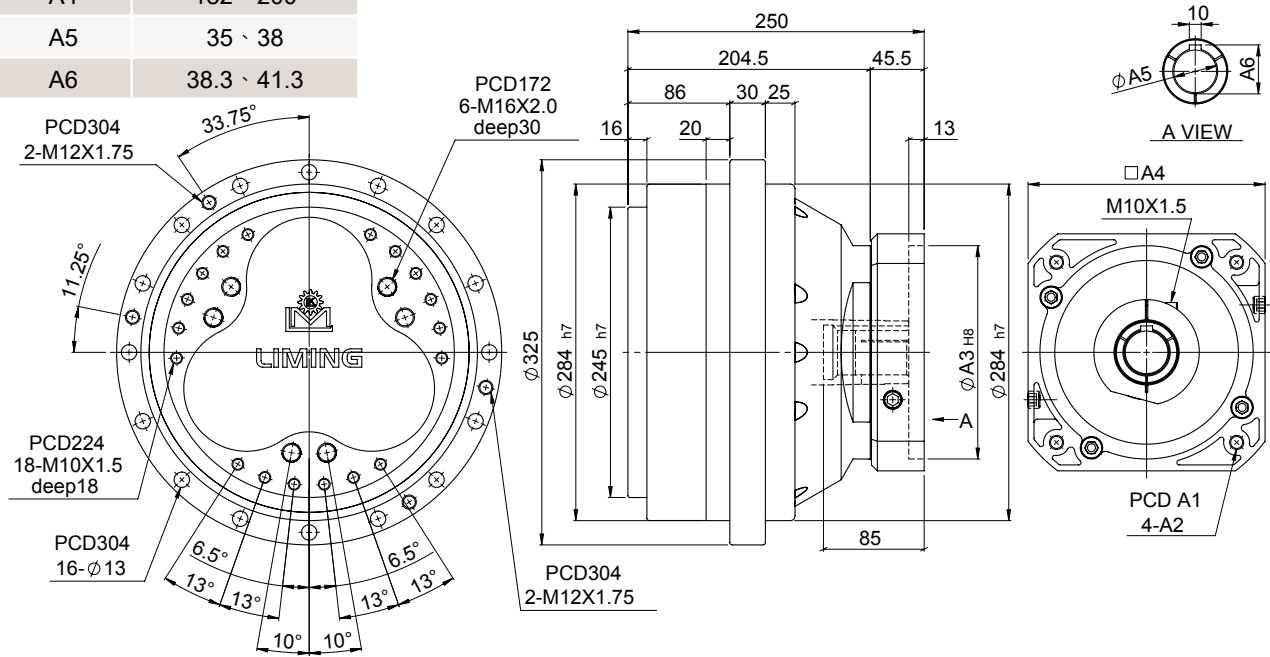
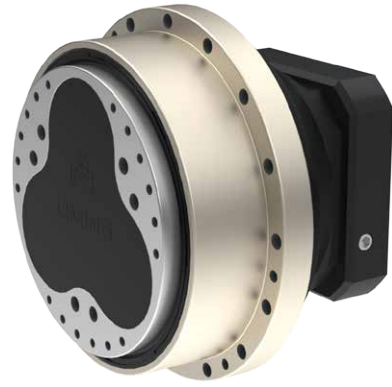

特性 Characteristic	代號	單位 Unit	RSN320
輸出平台支撐軸承 / Output Table Supporting Bearing			斜角滾珠軸承 Angular Contact Ball Bearing
額定輸出扭矩 / Rated Output Torque		Nm	3,200
最大輸出扭矩 / Max. Output Torque 急停扭矩 / Emergency Stop Torque	T_{2NOT}	Nm	5 倍額定輸出扭矩 5 Time of Rated Output Torque
最大加速力矩 / Max. Acceleration Torque	T_{2B}	Nm	2.5 倍額定輸出力矩 2.5 Times of Rated Output Torque
慣性慣量 / Inertia Moment		kg.m ²	17.83 x 10 ⁻⁴
額定出力轉速 / Rated Output Speed		rpm	15
最大輸出轉速 / Max. Output Speed		rpm	21
容許輸入轉速 / Permissible Input Speed		rpm	3,000
背隙 / Backlash Ps	J_i	arcmin	≤ 1
背隙 / Backlash P0	J_i	arcmin	≤ 3
背隙 / Backlash P1	J_i	arcmin	≤ 5
容許徑向力 / Max. Radial Force	F_{2rB}	N	25,300
容許軸向力 / Max. Axial Force	F_{2aB}	N	20,000
額定壽命 / Rated Life	L_H	hr	S5 周期運轉 : >6,000 (S1 連續運轉 : >3,000 hrs) S5 Cycle Operation: >6,000 (S1 Continuous Operation: >3,000 hrs)
扭轉剛性 / Torsional Rigidity		Nm/arcmin	980
效率 / Efficiency	η	%	≥ 85
重量 / Weight		kg	57.5

MODEL : RSN450

RATIO : 45、66、81、101、171

Unit: mm

Model Code	RSN450
A1	200、215、265
A2	M12、M14
A3	114.3、180、230
A4	222、220、250
A5	38、42
A6	10、12
A7	41.3、45.3
A8	85、115

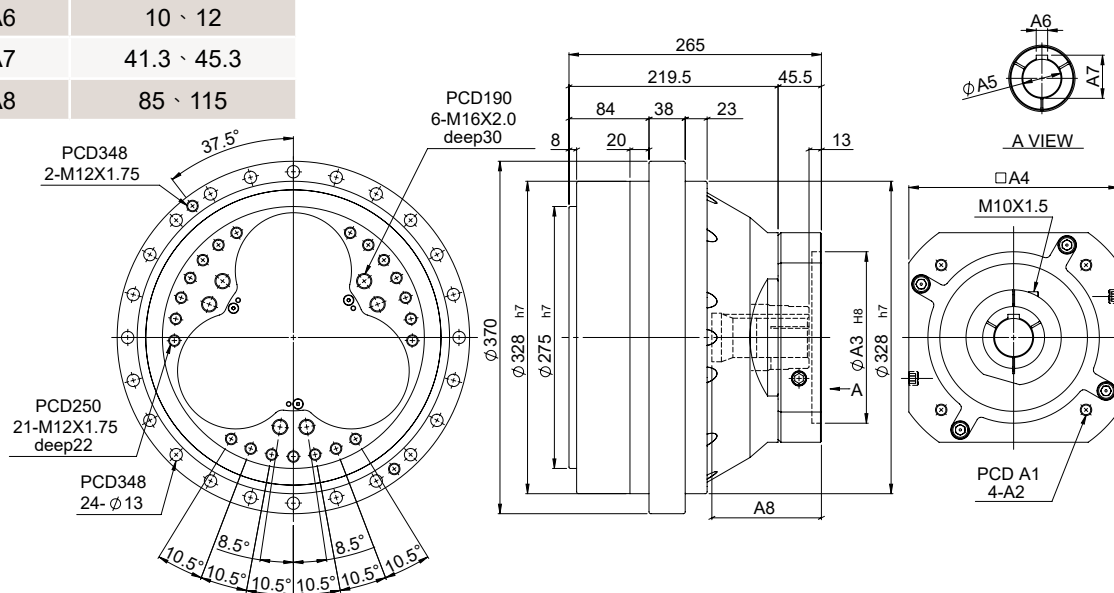

特性 Characteristic	代號	單位 Unit	RSN450
輸出平台支撐軸承 / Output Table Supporting Bearing			斜角滾珠軸承 Angular Contact Ball Bearing
額定輸出扭矩 / Rated Output Torque		Nm	4,500
最大輸出扭矩 / Max. Output Torque 急停扭矩 / Emergency Stop Torque	T_{2NOT}	Nm	5 倍額定輸出扭矩 5 Time of Rated Output Torque
最大加速力矩 / Max. Acceleration Torque	T_{2B}	Nm	2.5 倍額定輸出力矩 2.5 Times of Rated Output Torque
慣性慣量 / Inertia Moment		kg.m ²	37.96 x 10 ⁻⁴
額定出力轉速 / Rated Output Speed		rpm	15
最大輸出轉速 / Max. Output Speed		rpm	21
容許輸入轉速 / Permissible Input Speed		rpm	3,000
背隙 / Backlash Ps	J_i	arcmin	≤ 1
背隙 / Backlash P0	J_i	arcmin	≤ 3
背隙 / Backlash P1	J_i	arcmin	≤ 5
容許徑向力 / Max. Radial Force	F_{2rB}	N	30,000
容許軸向力 / Max. Axial Force	F_{2aB}	N	24,000
額定壽命 / Rated Life	L_H	hr	S5 周期運轉 : >6,000 (S1 連續運轉 : >3,000 hrs) S5 Cycle Operation: >6,000 (S1 Continuous Operation: >3,000 hrs)
扭轉剛性 / Torsional Rigidity		Nm/arcmin	7,400
效率 / Efficiency	η	%	≥ 85
重量 / Weight		kg	

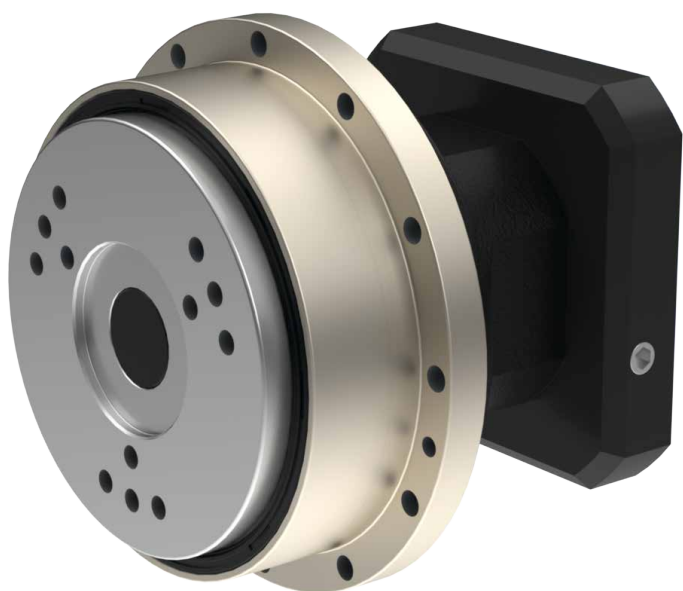

RDN

高精度擺線減速機

MODEL : RDN6

RATIO : 41、61、81、121、161

Unit: mm

Model Code	RDN6
A1	70、75、90
A2	M4、M5、M6
A3	50、60、70
A4	64、70、80

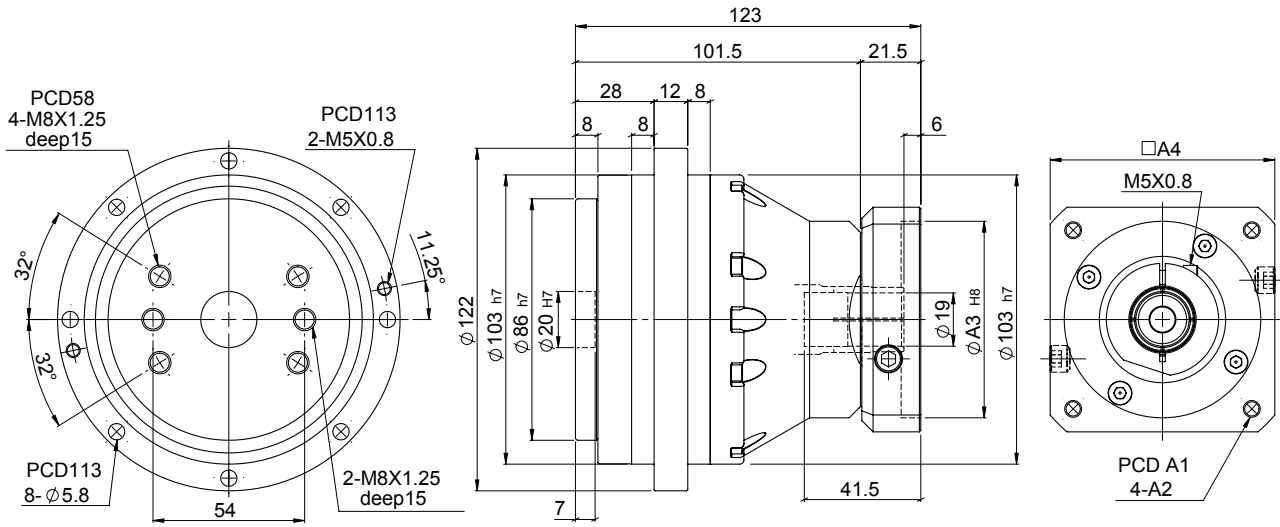

特性 Characteristic	代號	單位 Unit	RDN6
輸出平台支撐軸承 / Output Table Supporting Bearing			斜角滾珠軸承 Angular Contact Ball Bearing
額定輸出扭矩 / Rated Output Torque		Nm	60
最大輸出扭矩 / Max. Output Torque 急停扭矩 / Emergency Stop Torque	T_{2NOT}	Nm	5 倍額定輸出扭矩 5 Time of Rated Output Torque
最大加速力矩 / Max. Acceleration Torque	T_{2B}	Nm	2 倍額定輸出力矩 2Times of Rated Output Torque
慣性慣量 / Inertia Moment		kg.m ²	0.28 x 10 ⁻⁴
額定出力轉速 / Rated Output Speed		rpm	15
最大輸出轉速 / Max. Output Speed		rpm	55
容許輸入轉速 / Permissible Input Speed		rpm	3,000
背隙 / Backlash Ps	J_i	arcmin	≤ 2
背隙 / Backlash P0	J_i	arcmin	≤ 4
背隙 / Backlash P1	J_i	arcmin	≤ 6
容許徑向力 / Max. Radial Force	F_{2rB}	N	2,100
容許軸向力 / Max. Axial Force	F_{2aB}	N	1,500
額定壽命 / Rated Life	L_H	hr	S5 周期運轉 : >6,000 (S1 連續運轉 : >3,000 hrs) S5 Cycle Operation: >6,000 (S1 Continuous Operation: >3,000 hrs)
扭轉剛性 / Torsional Rigidity		Nm/arcmin	50
效率 / Efficiency	η	%	≥ 85
重量 / Weight		kg	3.5

MODEL : RDN20

RATIO : 41、61、81、121、161

Unit: mm

Model Code	RDN20
A1	90、100、115、145
A2	M5、M6、M8
A3	70、80、95、110
A4	92、110、130
A5	19、24
A6	51、63
A7	8、20
A8	26.5、38.5
A9	146、158

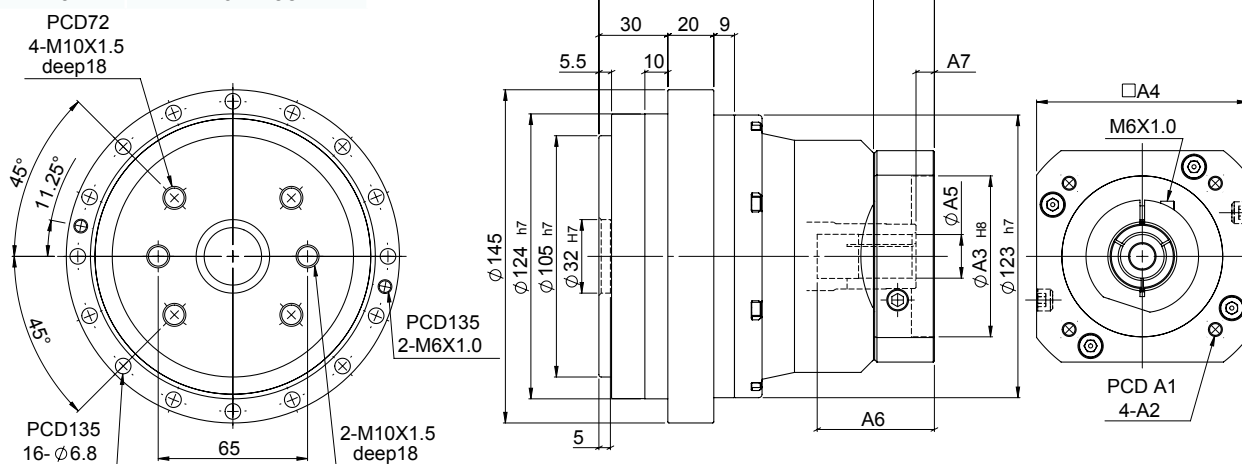

特性 Characteristic	代號	單位 Unit	RDN20
輸出平台支撐軸承 / Output Table Supporting Bearing			斜角滾珠軸承 Angular Contact Ball Bearing
額定輸出扭矩 / Rated Output Torque		Nm	200
最大輸出扭矩 / Max. Output Torque 急停扭矩 / Emergency Stop Torque	T_{2NOT}	Nm	5 倍額定輸出扭矩 5 Time of Rated Output Torque
最大加速力矩 / Max. Acceleration Torque	T_{2B}	Nm	2.5 倍額定輸出力矩 2.5 Times of Rated Output Torque
慣性慣量 / Inertia Moment		kg.m ²	0.71×10^{-4}
額定出力轉速 / Rated Output Speed		rpm	15
最大輸出轉速 / Max. Output Speed		rpm	50
容許輸入轉速 / Permissible Input Speed		rpm	3,000
背隙 / Backlash Ps	J_i	arcmin	≤ 1
背隙 / Backlash P0	J_i	arcmin	≤ 3
背隙 / Backlash P1	J_i	arcmin	≤ 5
容許徑向力 / Max. Radial Force	F_{2rB}	N	6,500
容許軸向力 / Max. Axial Force	F_{2aB}	N	4,300
額定壽命 / Rated Life	L_H	hr	S5 周期運轉 : >6,000 (S1 連續運轉 : >3,000 hrs) S5 Cycle Operation: >6,000 (S1 Continuous Operation: >3,000 hrs)
扭轉剛性 / Torsional Rigidity		Nm/arcmin	70
效率 / Efficiency	η	%	≥ 85
重量 / Weight		kg	6.7

MODEL : RDN40

RATIO : 41、61、81、121、161

Unit: mm

Model Code	RDN40
A1	115、145、165
A2	M6、M8、M10
A3	95、110、130
A4	122、130、150
A5	24、28

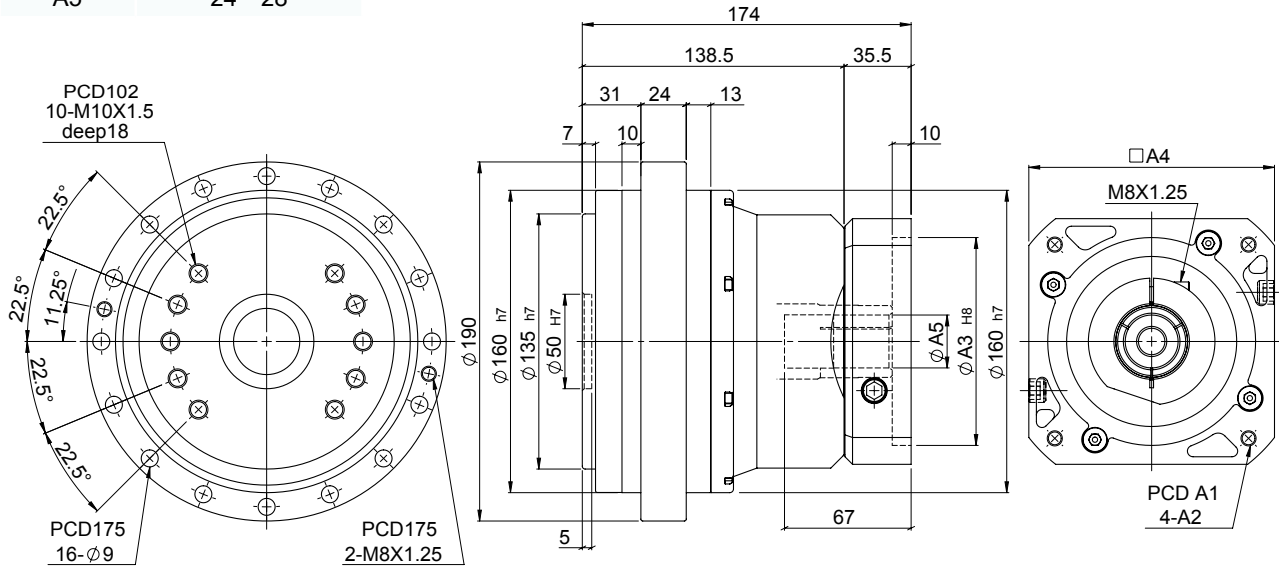

特性 Characteristic	代號	單位 Unit	RDN40
輸出平台支撐軸承 / Output Table Supporting Bearing			斜角滾珠軸承 Angular Contact Ball Bearing
額定輸出扭矩 / Rated Output Torque		Nm	400
最大輸出扭矩 / Max. Output Torque 急停扭矩 / Emergency Stop Torque	T_{2NOT}	Nm	5 倍額定輸出扭矩 5 Time of Rated Output Torque
最大加速力矩 / Max. Acceleration Torque	T_{2B}	Nm	2.5 倍額定輸出力矩 2.5 Times of Rated Output Torque
慣性慣量 / Inertia Moment		kg.m ²	3.24×10^{-4}
額定出力轉速 / Rated Output Speed		rpm	15
最大輸出轉速 / Max. Output Speed		rpm	45
容許輸入轉速 / Permissible Input Speed		rpm	3,000
背隙 / Backlash Ps	J_i	arcmin	≤ 1
背隙 / Backlash P0	J_i	arcmin	≤ 3
背隙 / Backlash P1	J_i	arcmin	≤ 5
容許徑向力 / Max. Radial Force	F_{2rB}	N	8,600
容許軸向力 / Max. Axial Force	F_{2aB}	N	5,700
額定壽命 / Rated Life	L_H	hr	S5 周期運轉 : >6,000 (S1 連續運轉 : >3,000 hrs) S5 Cycle Operation: >6,000 (S1 Continuous Operation: >3,000 hrs)
扭轉剛性 / Torsional Rigidity		Nm/arcmin	100
效率 / Efficiency	η	%	≥ 85
重量 / Weight		kg	12.0

MODEL : RDN110

RATIO : 41、61、81、121、161

Unit: mm

Model Code	RDN110
A1	145、165、200
A2	M8、M10、M12
A3	110、130、180
A4	130、150、190
A5	32、35
A6	35.3、38.3

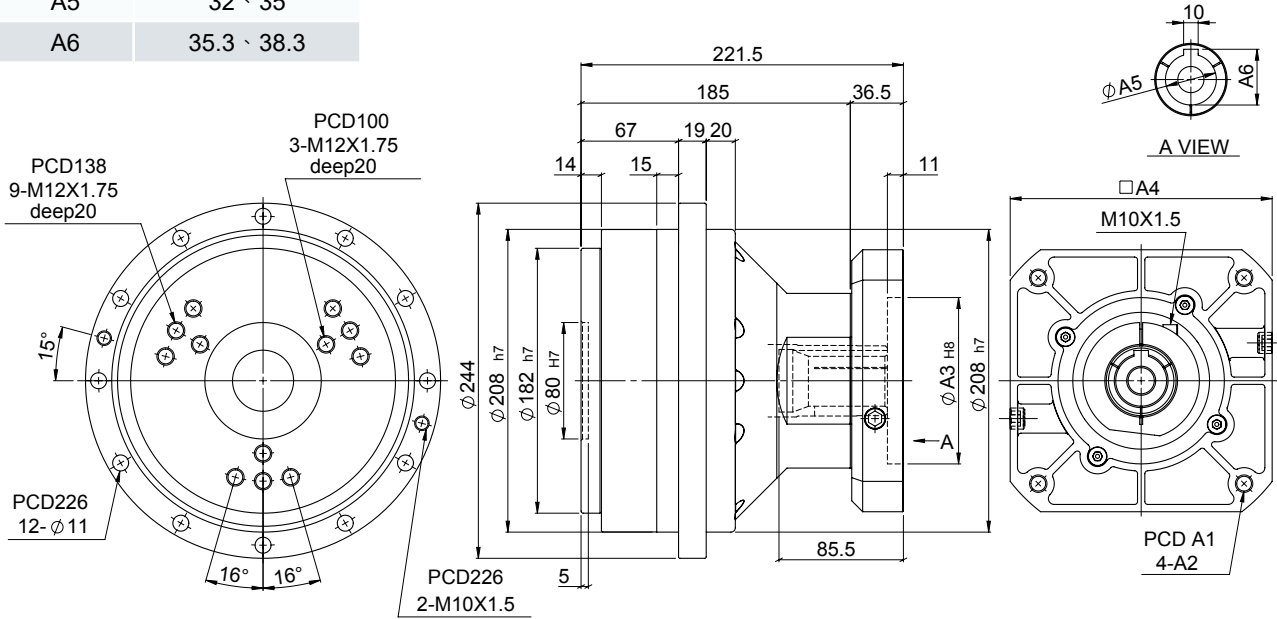
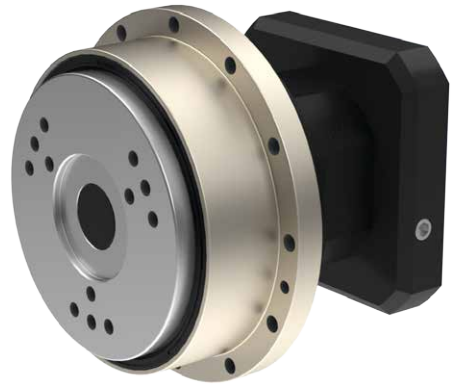

特性 Characteristic	代號	單位 Unit	RDN110
輸出平台支撐軸承 / Output Table Supporting Bearing			斜角滾珠軸承 Angular Contact Ball Bearing
額定輸出扭矩 / Rated Output Torque		Nm	1,100
最大輸出扭矩 / Max. Output Torque 急停扭矩 / Emergency Stop Torque	T_{2NOT}	Nm	5 倍額定輸出扭矩 5 Time of Rated Output Torque
最大加速力矩 / Max. Acceleration Torque	T_{2B}	Nm	2.5 倍額定輸出力矩 2.5 Times of Rated Output Torque
慣性慣量 / Inertia Moment		kg.m ²	8.71×10^{-4}
額定出力轉速 / Rated Output Speed		rpm	15
最大輸出轉速 / Max. Output Speed		rpm	35
容許輸入轉速 / Permissible Input Speed		rpm	3,000
背隙 / Backlash Ps	J_i	arcmin	≤ 1
背隙 / Backlash P0	J_i	arcmin	≤ 3
背隙 / Backlash P1	J_i	arcmin	≤ 5
容許徑向力 / Max. Radial Force	F_{2rB}	N	16,000
容許軸向力 / Max. Axial Force	F_{2aB}	N	12,000
額定壽命 / Rated Life	L_H	hr	S5 周期運轉 : >6,000 (S1 連續運轉 : >3,000 hrs) S5 Cycle Operation: >6,000 (S1 Continuous Operation: >3,000 hrs)
扭轉剛性 / Torsional Rigidity		Nm/arcmin	210
效率 / Efficiency	η	%	≥ 85
重量 / Weight		kg	27.9

MODEL : RDN160

RATIO : 41、61、81、121、161

Unit: mm

Model Code	RDN160
A1	165、200、215
A2	M8、M10、M12
A3	114.3、130、180
A4	180、200
A5	35、38
A6	38.3、41.3

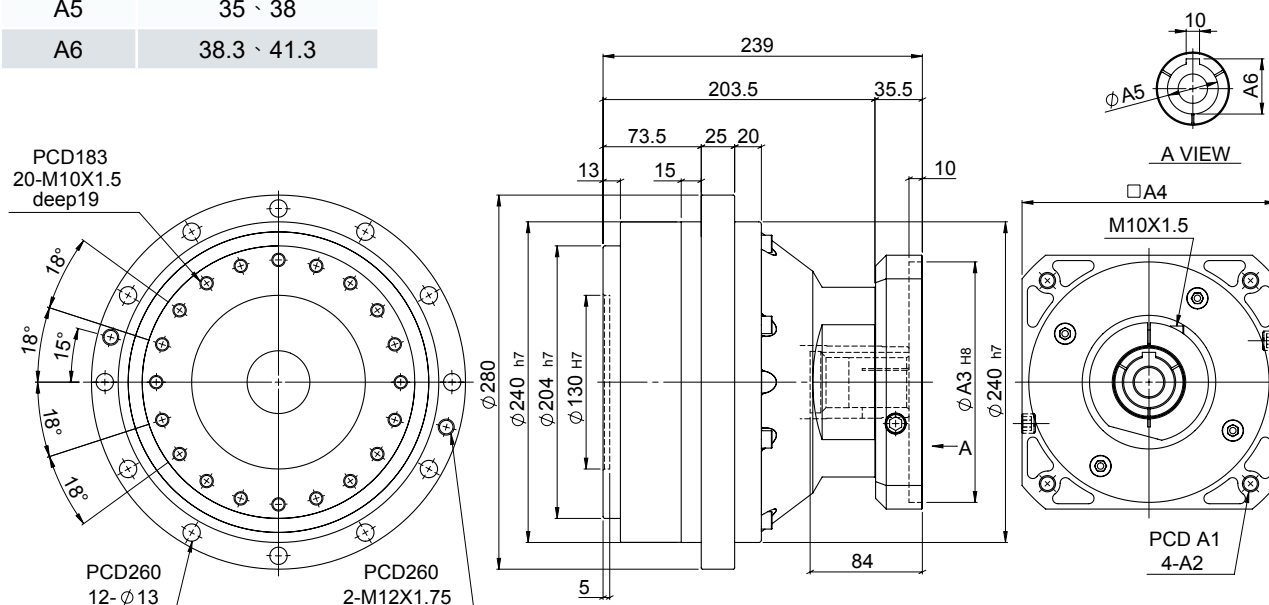
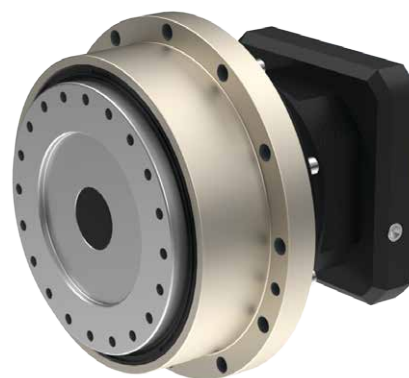

特性 Characteristic	代號	單位 Unit	RDN160
輸出平台支撐軸承 / Output Table Supporting Bearing			斜角滾珠軸承 Angular Contact Ball Bearing
額定輸出扭矩 / Rated Output Torque		Nm	1,600
最大輸出扭矩 / Max. Output Torque 急停扭矩 / Emergency Stop Torque	T_{2NOT}	Nm	5 倍額定輸出扭矩 5 Time of Rated Output Torque
最大加速力矩 / Max. Acceleration Torque	T_{2B}	Nm	2.5 倍額定輸出力矩 2.5 Times of Rated Output Torque
慣性慣量 / Inertia Moment		kg.m ²	13.68 x 10 ⁻⁴
額定出力轉速 / Rated Output Speed		rpm	15
最大輸出轉速 / Max. Output Speed		rpm	27
容許輸入轉速 / Permissible Input Speed		rpm	3,000
背隙 / Backlash Ps	J_i	arcmin	≤ 1
背隙 / Backlash P0	J_i	arcmin	≤ 3
背隙 / Backlash P1	J_i	arcmin	≤ 5
容許徑向力 / Max. Radial Force	F_{2rB}	N	19,000
容許軸向力 / Max. Axial Force	F_{2aB}	N	15,000
額定壽命 / Rated Life	L_H	hr	S5 周期運轉 : >6,000 (S1 連續運轉 : >3,000 hrs) S5 Cycle Operation: >6,000 (S1 Continuous Operation: >3,000 hrs)
扭轉剛性 / Torsional Rigidity		Nm/arcmin	300
效率 / Efficiency	η	%	≥ 85
重量 / Weight		kg	37.5

MODEL : RDN320

RATIO : 41、61、81、121、161

Unit: mm

Model Code	RDN320
A1	200、215、265
A2	M10、M12、M16
A3	114.3、180、230
A4	182、200、250
A5	42、48
A6	12、14
A7	45.3、51.8

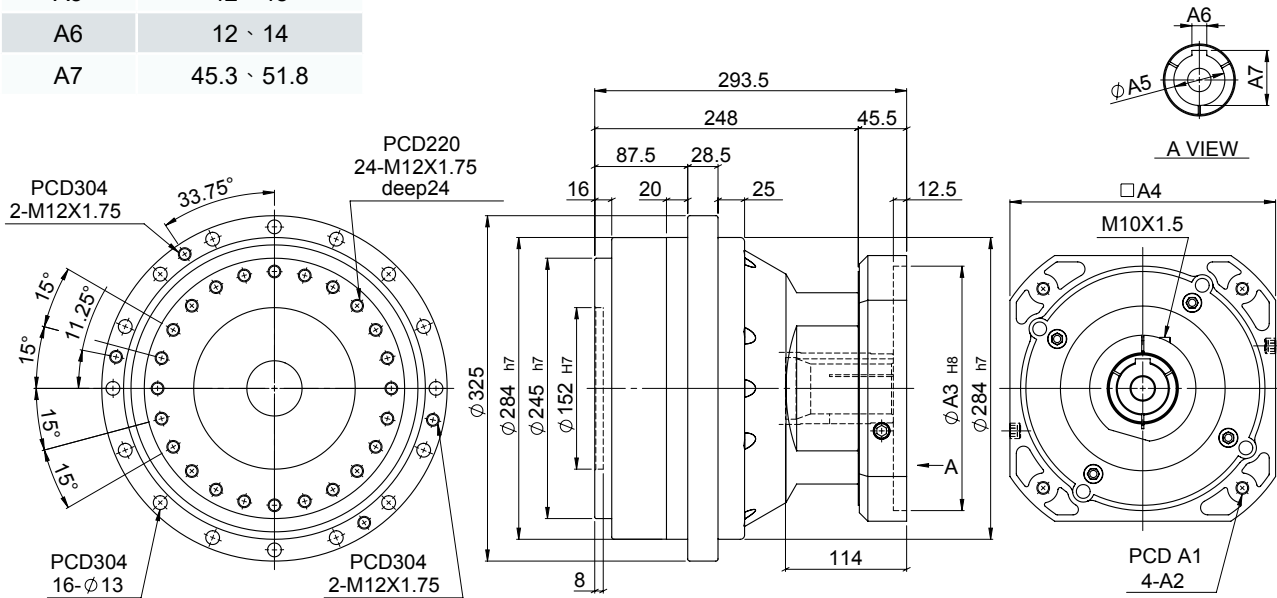
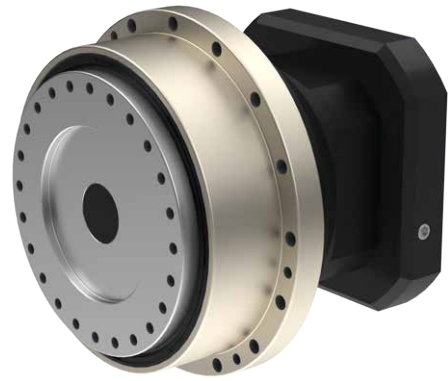

特性 Characteristic	代號	單位 Unit	RDN320
輸出平台支撐軸承 / Output Table Supporting Bearing			斜角滾珠軸承 Angular Contact Ball Bearing
額定輸出扭矩 / Rated Output Torque		Nm	3,200
最大輸出扭矩 / Max. Output Torque 急停扭矩 / Emergency Stop Torque	T_{2NOT}	Nm	5 倍額定輸出扭矩 5 Time of Rated Output Torque
最大加速力矩 / Max. Acceleration Torque	T_{2B}	Nm	2.5 倍額定輸出力矩 2.5 Times of Rated Output Torque
慣性慣量 / Inertia Moment		kg.m ²	27.46 x 10 ⁻⁴
額定出力轉速 / Rated Output Speed		rpm	15
最大輸出轉速 / Max. Output Speed		rpm	21
容許輸入轉速 / Permissible Input Speed		rpm	3,000
背隙 / Backlash Ps	J_i	arcmin	≤ 1
背隙 / Backlash P0	J_i	arcmin	≤ 3
背隙 / Backlash P1	J_i	arcmin	≤ 5
容許徑向力 / Max. Radial Force	F_{2rB}	N	25,300
容許軸向力 / Max. Axial Force	F_{2aB}	N	20,000
額定壽命 / Rated Life	L_H	hr	S5 周期運轉 : >6,000 (S1 連續運轉 : >3,000 hrs) S5 Cycle Operation: >6,000 (S1 Continuous Operation: >3,000 hrs)
扭轉剛性 / Torsional Rigidity		Nm/arcmin	980
效率 / Efficiency	η	%	≥ 85
重量 / Weight		kg	64.3

MODEL : RDN450

RATIO : 45、66、81、101、171

Unit: mm

Model Code	RDN450
A1	215、265、300
A2	M12、M14、M16
A3	180、230、250
A4	220、250、265
A5	48、55
A6	14、16
A7	51.8、59.3

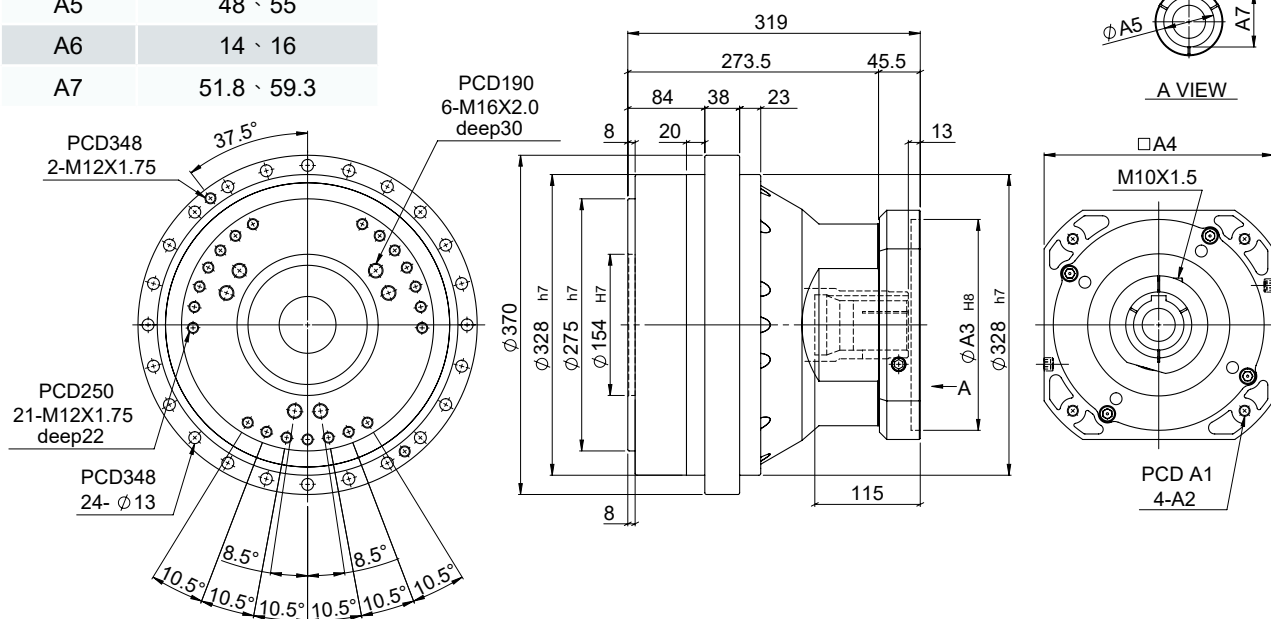

特性 Characteristic	代號	單位 Unit	RDN450
輸出平台支撐軸承 / Output Table Supporting Bearing			斜角滾珠軸承 Angular Contact Ball Bearing
額定輸出扭矩 / Rated Output Torque		Nm	4,500
最大輸出扭矩 / Max. Output Torque 急停扭矩 / Emergency Stop Torque	T_{2NOT}	Nm	5 倍額定輸出扭矩 5 Time of Rated Output Torque
最大加速力矩 / Max. Acceleration Torque	T_{2B}	Nm	2.5 倍額定輸出力矩 2.5 Times of Rated Output Torque
慣性慣量 / Inertia Moment		kg.m ²	44.95 x 10 ⁻⁴
額定出力轉速 / Rated Output Speed		rpm	15
最大輸出轉速 / Max. Output Speed		rpm	21
容許輸入轉速 / Permissible Input Speed		rpm	3,000
背隙 / Backlash Ps	J_i	arcmin	≤ 1
背隙 / Backlash P0	J_i	arcmin	≤ 3
背隙 / Backlash P1	J_i	arcmin	≤ 5
容許徑向力 / Max. Radial Force	F_{2rB}	N	30,000
容許軸向力 / Max. Axial Force	F_{2aB}	N	24,000
額定壽命 / Rated Life	L_H	hr	S5 周期運轉 : >6,000 (S1 連續運轉 : >3,000 hrs) S5 Cycle Operation: >6,000 (S1 Continuous Operation: >3,000 hrs)
扭轉剛性 / Torsional Rigidity		Nm/arcmin	7,400
效率 / Efficiency	η	%	≥ 85
重量 / Weight		kg	

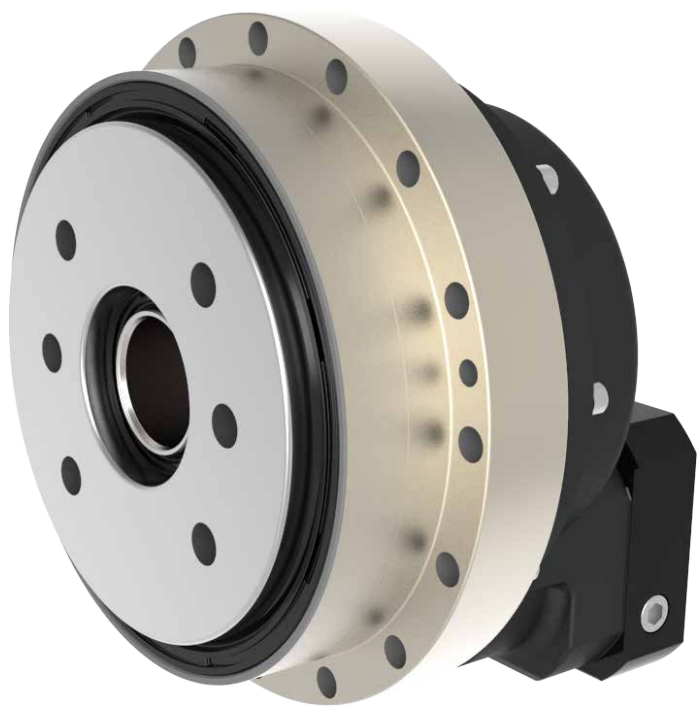

RCN

高精度擺線減速機

MODEL : RCN6

RATIO : 75、100、125、150

Unit: mm

Model Code	RCN6
A1	70、75、90
A2	M4、M5、M6
A3	50、60、70
A4	64、70、80

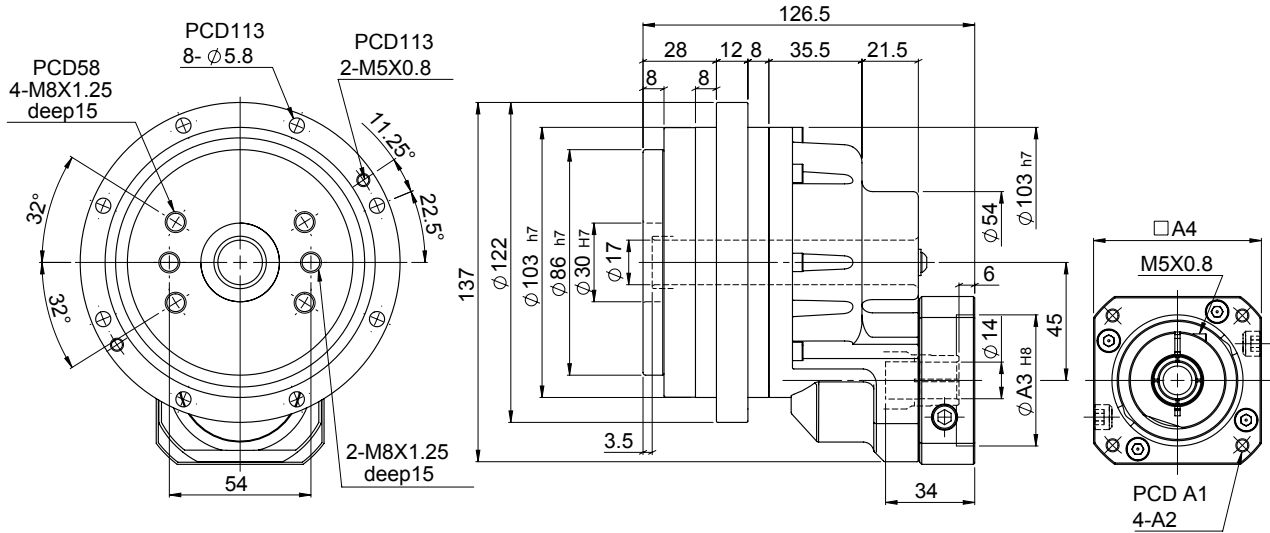

特性 Characteristic	代號	單位 Unit	RCN6
輸出平台支撐軸承 / Output Table Supporting Bearing			斜角滾珠軸承 Angular Contact Ball Bearing
額定輸出扭矩 / Rated Output Torque		Nm	60
最大輸出扭矩 / Max. Output Torque 急停扭矩 / Emergency Stop Torque	T_{2NOT}	Nm	5 倍額定輸出扭矩 5 Time of Rated Output Torque
最大加速力矩 / Max. Acceleration Torque	T_{2B}	Nm	2 倍額定輸出力矩 2 Times of Rated Output Torque
慣性慣量 / Inertia Moment		kg.m ²	0.21 x 10 ⁻⁴
額定出力轉速 / Rated Output Speed		rpm	15
最大輸出轉速 / Max. Output Speed		rpm	55
容許輸入轉速 / Permissible Input Speed		rpm	3,000
背隙 / Backlash Ps	J_i	arcmin	≤ 2
背隙 / Backlash P0	J_i	arcmin	≤ 4
背隙 / Backlash P1	J_i	arcmin	≤ 6
容許徑向力 / Max. Radial Force	F_{2rB}	N	2,100
容許軸向力 / Max. Axial Force	F_{2aB}	N	1,500
額定壽命 / Rated Life	L_H	hr	S5 周期運轉 : >6,000 (S1 連續運轉 : >3,000 hrs) S5 Cycle Operation: >6,000 (S1 Continuous Operation: >3,000 hrs)
扭轉剛性 / Torsional Rigidity		Nm/arcmin	50
效率 / Efficiency	η	%	≥ 85
重量 / Weight		kg	3.7

MODEL : RCN20

RATIO : 69、115、138

Unit: mm

Model Code	RCN20
A1	70、75、90
A2	M4、M5、M6
A3	50、60、70
A4	64、70、80
A5	※ 14、19
A6	33.5、41.5



※ Ø14 : 1/69、1/115、1/138
 Ø19 : 1/69、1/115

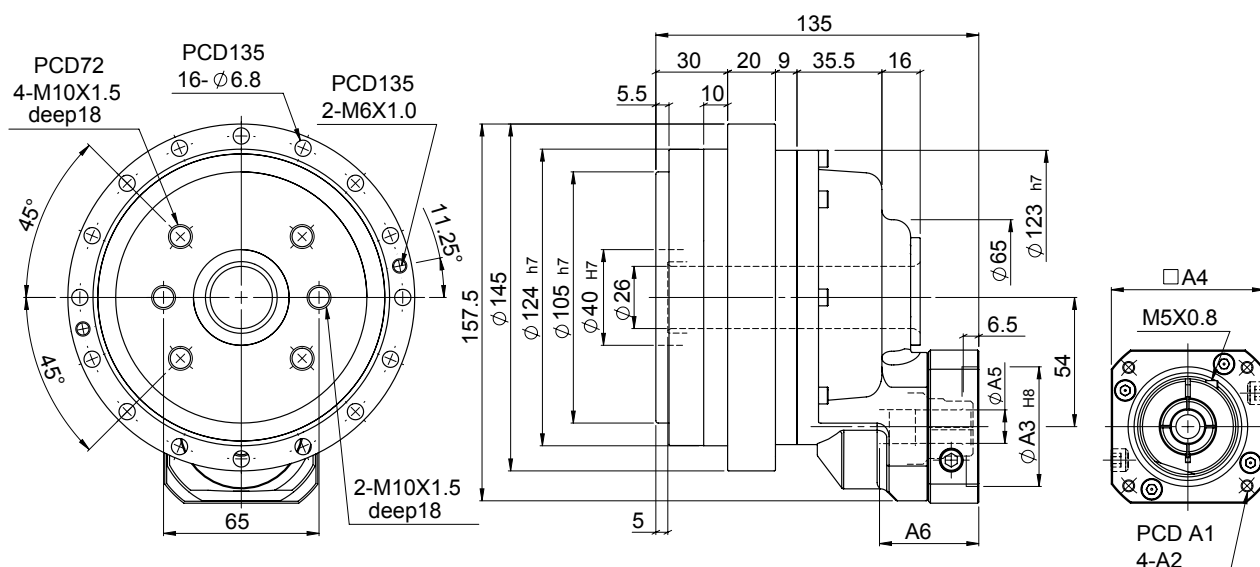

特性 Characteristic	代號	單位 Unit	RCN20
輸出平台支撐軸承 / Output Table Supporting Bearing			斜角滾珠軸承 Angular Contact Ball Bearing
額定輸出扭矩 / Rated Output Torque		Nm	200
最大輸出扭矩 / Max. Output Torque 急停扭矩 / Emergency Stop Torque	T_{2NOT}	Nm	5 倍額定輸出扭矩 5 Time of Rated Output Torque
最大加速力矩 / Max. Acceleration Torque	T_{2B}	Nm	2.5 倍額定輸出力矩 2.5 Times of Rated Output Torque
慣性慣量 / Inertia Moment		kg.m ²	0.35 x 10 ⁻⁴
額定出力轉速 / Rated Output Speed		rpm	15
最大輸出轉速 / Max. Output Speed		rpm	50
容許輸入轉速 / Permissible Input Speed		rpm	3,000
背隙 / Backlash Ps	J_i	arcmin	≤ 1
背隙 / Backlash P0	J_i	arcmin	≤ 3
背隙 / Backlash P1	J_i	arcmin	≤ 5
容許徑向力 / Max. Radial Force	F_{2rB}	N	6,500
容許軸向力 / Max. Axial Force	F_{2aB}	N	4,300
額定壽命 / Rated Life	L_H	hr	S5 周期運轉 : >6,000 (S1 連續運轉 : >3,000 hrs) S5 Cycle Operation: >6,000 (S1 Continuous Operation: >3,000 hrs)
扭轉剛性 / Torsional Rigidity		Nm/arcmin	70
效率 / Efficiency	η	%	≥ 85
重量 / Weight		kg	6.6

MODEL : RCN40

RATIO : 87、116、145

Unit: mm

Model Code	RCN40
A1	90、100、115、145
A2	M5、M6、M8
A3	70、80、95、110
A4	92、110、130
A5	※19、22
A6	21.8、24.8
A7	42、52



※ Ø19 : 1/87、1/116、1/145
 Ø22 : 1/87、1/116

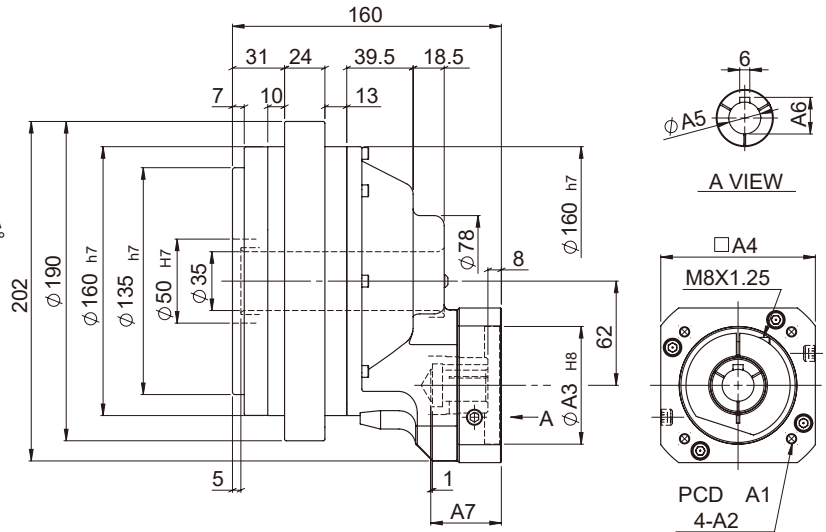
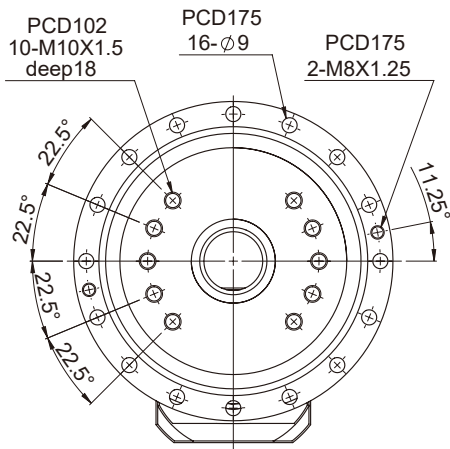

特性 Characteristic	代號	單位 Unit	RCN40
輸出平台支撐軸承 / Output Table Supporting Bearing			斜角滾珠軸承 Angular Contact Ball Bearing
額定輸出扭矩 / Rated Output Torque		Nm	400
最大輸出扭矩 / Max. Output Torque 急停扭矩 / Emergency Stop Torque	T_{2NOT}	Nm	5 倍額定輸出扭矩 5 Time of Rated Output Torque
最大加速力矩 / Max. Acceleration Torque	T_{2B}	Nm	2.5 倍額定輸出力矩 2.5 Times of Rated Output Torque
慣性慣量 / Inertia Moment		kg.m ²	2.12×10^{-4}
額定出力轉速 / Rated Output Speed		rpm	15
最大輸出轉速 / Max. Output Speed		rpm	45
容許輸入轉速 / Permissible Input Speed		rpm	3,000
背隙 / Backlash Ps	J_i	arcmin	≤ 1
背隙 / Backlash P0	J_i	arcmin	≤ 3
背隙 / Backlash P1	J_i	arcmin	≤ 5
容許徑向力 / Max. Radial Force	F_{2rB}	N	8,600
容許軸向力 / Max. Axial Force	F_{2aB}	N	5,700
額定壽命 / Rated Life	L_H	hr	S5 周期運轉 : >6,000 (S1 連續運轉 : >3,000 hrs) S5 Cycle Operation: >6,000 (S1 Continuous Operation: >3,000 hrs)
扭轉剛性 / Torsional Rigidity		Nm/arcmin	100
效率 / Efficiency	η	%	≥ 85
重量 / Weight		kg	11.7

MODEL : RCN80

RATIO : 78、104、130

Unit: mm

Model Code	RCN80
A1	90、100、115、145
A2	M5、M6、M8
A3	70、80、95、110
A4	92、110、130
A5	22、24
A6	6、8
A7	24.8、27.3

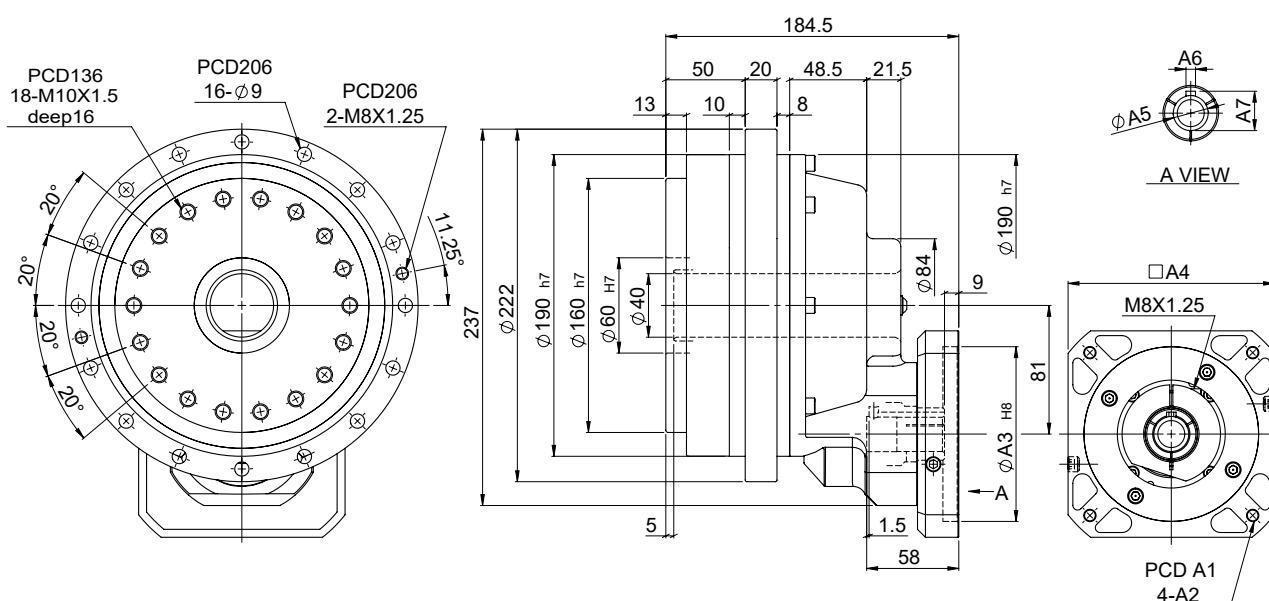

特性 Characteristic	代號	單位 Unit	RCN80
輸出平台支撐軸承 / Output Table Supporting Bearing			斜角滾珠軸承 Angular Contact Ball Bearing
額定輸出扭矩 / Rated Output Torque		Nm	800
最大輸出扭矩 / Max. Output Torque 急停扭矩 / Emergency Stop Torque	T_{2NOT}	Nm	5 倍額定輸出扭矩 5 Time of Rated Output Torque
最大加速力矩 / Max. Acceleration Torque	T_{2B}	Nm	2.5 倍額定輸出力矩 2.5 Times of Rated Output Torque
慣性慣量 / Inertia Moment		kg.m ²	2.63×10^{-4}
額定出力轉速 / Rated Output Speed		rpm	15
最大輸出轉速 / Max. Output Speed		rpm	42
容許輸入轉速 / Permissible Input Speed		rpm	3,000
背隙 / Backlash Ps	J_i	arcmin	≤ 1
背隙 / Backlash P0	J_i	arcmin	≤ 3
背隙 / Backlash P1	J_i	arcmin	≤ 5
容許徑向力 / Max. Radial Force	F_{2rB}	N	12,500
容許軸向力 / Max. Axial Force	F_{2aB}	N	8,200
額定壽命 / Rated Life	L_H	hr	S5 周期運轉 : >6,000 (S1 連續運轉 : >3,000 hrs) S5 Cycle Operation: >6,000 (S1 Continuous Operation: >3,000 hrs)
扭轉剛性 / Torsional Rigidity		Nm/arcmin	150
效率 / Efficiency	η	%	≥ 85
重量 / Weight		kg	19.3

Unit: mm

MODEL : RCN110

RATIO : 66、99、132

Model Code	RCN110
A1	115、145、165
A2	M6、M8、M10
A3	95、110、130
A4	122、130、150
A5	24、28
A6	27.3、31.3

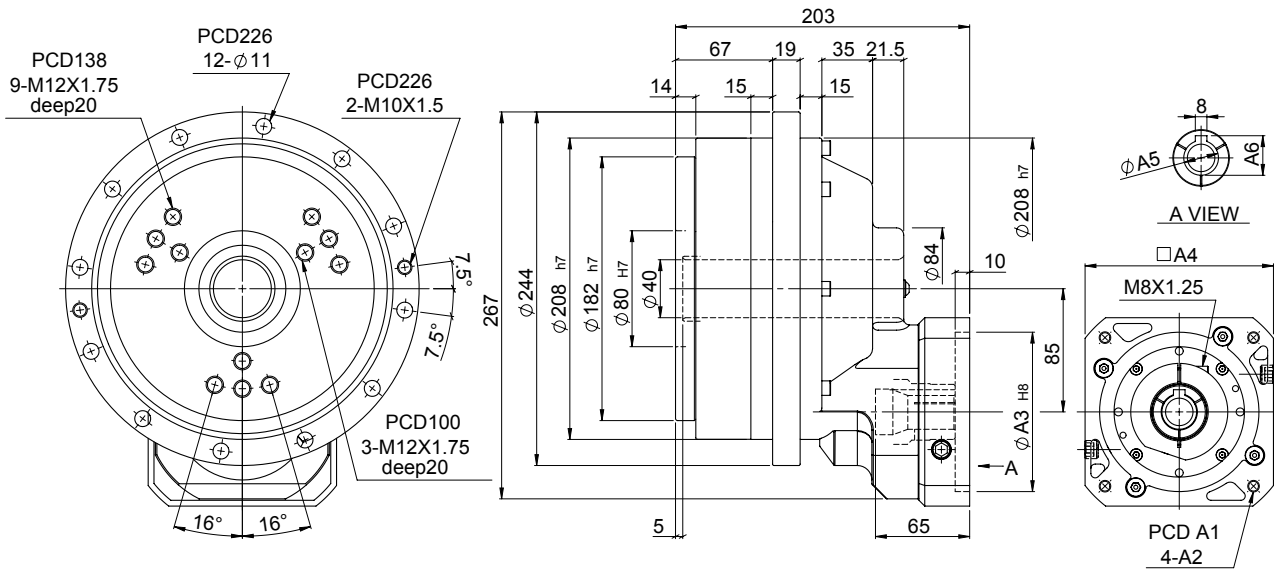

特性 Characteristic	代號	單位 Unit	RCN110
輸出平台支撐軸承 / Output Table Supporting Bearing			斜角滾珠軸承 Angular Contact Ball Bearing
額定輸出扭矩 / Rated Output Torque		Nm	1,100
最大輸出扭矩 / Max. Output Torque 急停扭矩 / Emergency Stop Torque	T_{2NOT}	Nm	5 倍額定輸出扭矩 5 Time of Rated Output Torque
最大加速力矩 / Max. Acceleration Torque	T_{2B}	Nm	2.5 倍額定輸出力矩 2.5 Times of Rated Output Torque
慣性慣量 / Inertia Moment		kg.m ²	5.14×10^{-4}
額定出力轉速 / Rated Output Speed		rpm	15
最大輸出轉速 / Max. Output Speed		rpm	35
容許輸入轉速 / Permissible Input Speed		rpm	3,000
背隙 / Backlash Ps	J_i	arcmin	≤ 1
背隙 / Backlash P0	J_i	arcmin	≤ 3
背隙 / Backlash P1	J_i	arcmin	≤ 5
容許徑向力 / Max. Radial Force	F_{2rB}	N	16,000
容許軸向力 / Max. Axial Force	F_{2aB}	N	12,000
額定壽命 / Rated Life	L_H	hr	S5 周期運轉 : >6,000 (S1 連續運轉 : >3,000 hrs) S5 Cycle Operation: >6,000 (S1 Continuous Operation: >3,000 hrs)
扭轉剛性 / Torsional Rigidity		Nm/arcmin	210
效率 / Efficiency	η	%	≥ 85
重量 / Weight		kg	27.8

MODEL : RCN160

RATIO : 66、99、132

Unit: mm

Model Code	RCN160
A1	115、145、165
A2	M6、M8、M10
A3	95、110、130
A4	122、130、150
A5	28、32
A6	8、10
A7	31.3、35.3

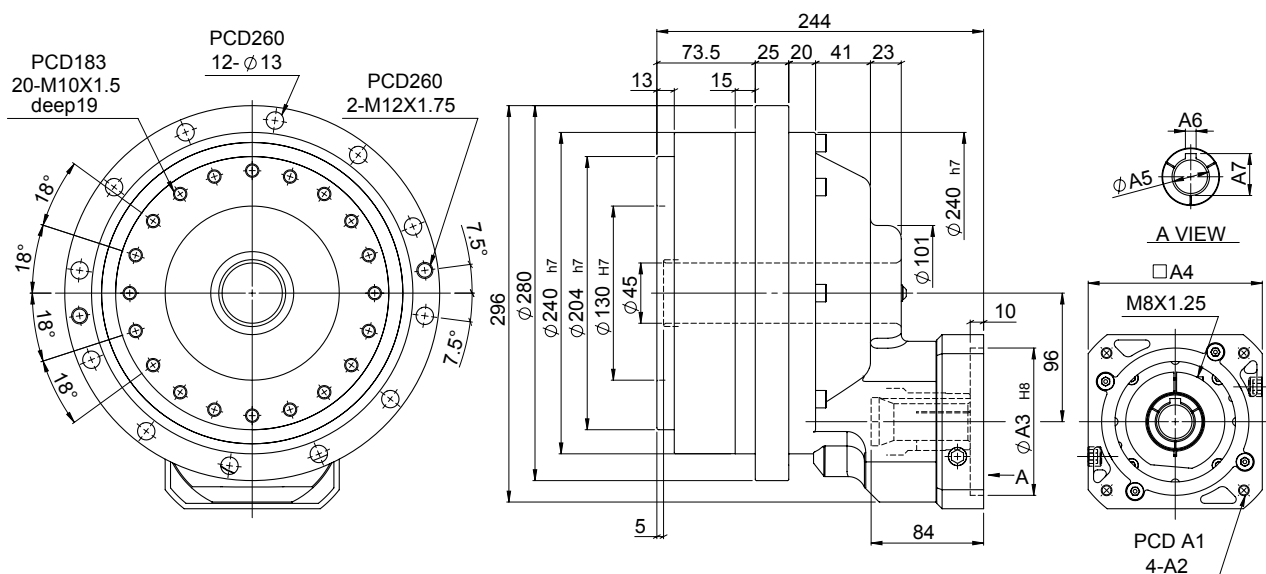

特性 Characteristic	代號	單位 Unit	RCN160
輸出平台支撐軸承 / Output Table Supporting Bearing			斜角滾珠軸承 Angular Contact Ball Bearing
額定輸出扭矩 / Rated Output Torque		Nm	1,600
最大輸出扭矩 / Max. Output Torque 急停扭矩 / Emergency Stop Torque	T_{2NOT}	Nm	5 倍額定輸出扭矩 5 Time of Rated Output Torque
最大加速力矩 / Max. Acceleration Torque	T_{2B}	Nm	2.5 倍額定輸出力矩 2.5 Times of Rated Output Torque
慣性慣量 / Inertia Moment		kg.m ²	8.87×10^{-4}
額定出力轉速 / Rated Output Speed		rpm	15
最大輸出轉速 / Max. Output Speed		rpm	27
容許輸入轉速 / Permissible Input Speed		rpm	3,000
背隙 / Backlash Ps	J_i	arcmin	≤ 1
背隙 / Backlash P0	J_i	arcmin	≤ 3
背隙 / Backlash P1	J_i	arcmin	≤ 5
容許徑向力 / Max. Radial Force	F_{2rB}	N	19,000
容許軸向力 / Max. Axial Force	F_{2aB}	N	15,000
額定壽命 / Rated Life	L_H	hr	S5 周期運轉 : >6,000 (S1 連續運轉 : >3,000 hrs) S5 Cycle Operation: >6,000 (S1 Continuous Operation: >3,000 hrs)
扭轉剛性 / Torsional Rigidity		Nm/arcmin	300
效率 / Efficiency	η	%	≥ 85
重量 / Weight		kg	37.6

Unit: mm

MODEL : RCN320

RATIO : 82、123、164

Model Code	RCN320
A1	145、165、200
A2	M8、M10、M12
A3	110、130、180
A4	146、150、190
A5	32、35
A6	35.3、38.3

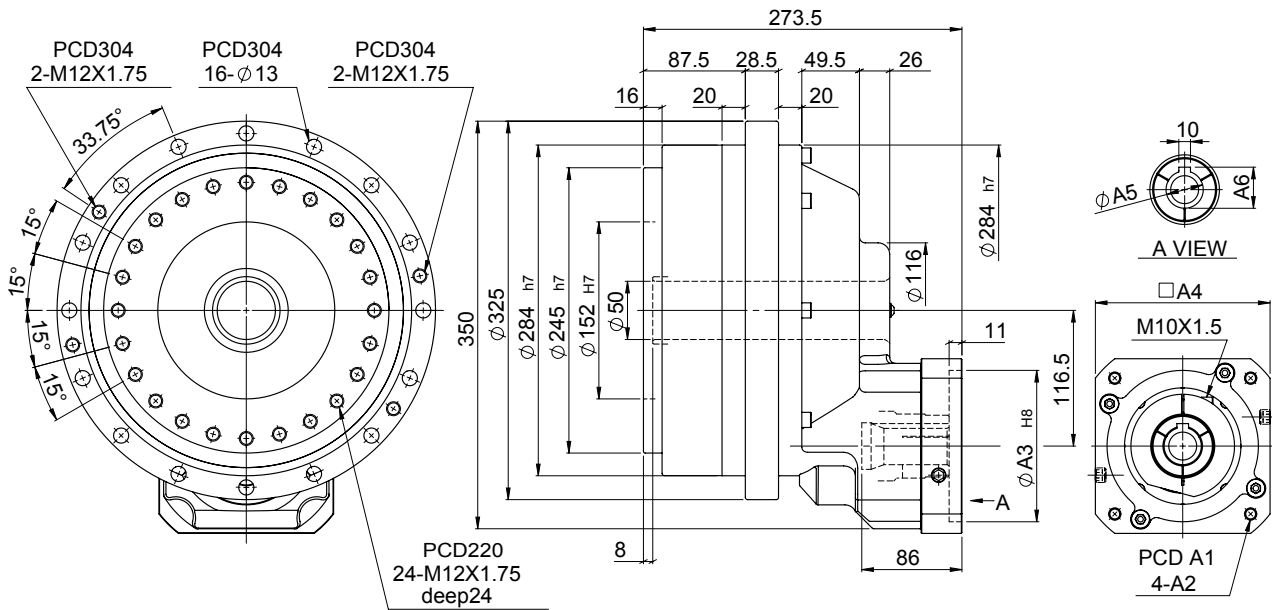

特性 Characteristic	代號	單位 Unit	RCN320
輸出平台支撐軸承 / Output Table Supporting Bearing			斜角滾珠軸承 Angular Contact Ball Bearing
額定輸出扭矩 / Rated Output Torque		Nm	3,200
最大輸出扭矩 / Max. Output Torque 急停扭矩 / Emergency Stop Torque	T_{2NOT}	Nm	5 倍額定輸出扭矩 5 Time of Rated Output Torque
最大加速力矩 / Max. Acceleration Torque	T_{2B}	Nm	2.5 倍額定輸出力矩 2.5 Times of Rated Output Torque
慣性慣量 / Inertia Moment		kg.m ²	22.13 x 10 ⁻⁴
額定出力轉速 / Rated Output Speed		rpm	15
最大輸出轉速 / Max. Output Speed		rpm	21
容許輸入轉速 / Permissible Input Speed		rpm	3,000
背隙 / Backlash Ps	J_i	arcmin	≤ 1
背隙 / Backlash P0	J_i	arcmin	≤ 3
背隙 / Backlash P1	J_i	arcmin	≤ 5
容許徑向力 / Max. Radial Force	F_{2rB}	N	25,300
容許軸向力 / Max. Axial Force	F_{2aB}	N	20,000
額定壽命 / Rated Life	L_H	hr	S5 周期運轉 : >6,000 (S1 連續運轉 : >3,000 hrs) S5 Cycle Operation: >6,000 (S1 Continuous Operation: >3,000 hrs)
扭轉剛性 / Torsional Rigidity		Nm/arcmin	980
效率 / Efficiency	η	%	≥ 85
重量 / Weight		kg	65.0

MODEL : RCN450

RATIO : 82、123、164

Unit: mm

Model Code	RCN450
A1	165、200、215
A2	M8、M10、M12
A3	114.3、130、180
A4	182、200
A5	35、38
A6	38.3、41.3

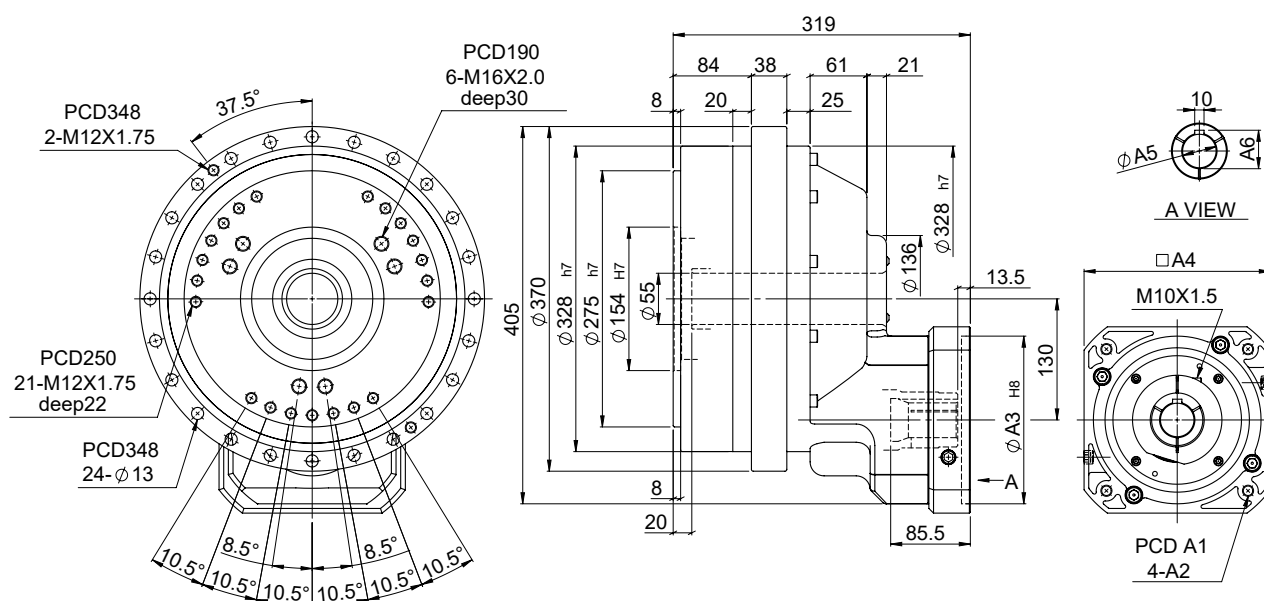

特性 Characteristic	代號	單位 Unit	RCN450
輸出平台支撐軸承 / Output Table Supporting Bearing			斜角滾珠軸承 Angular Contact Ball Bearing
額定輸出扭矩 / Rated Output Torque		Nm	4,500
最大輸出扭矩 / Max. Output Torque 急停扭矩 / Emergency Stop Torque	T_{2NOT}	Nm	5 倍額定輸出扭矩 5 Time of Rated Output Torque
最大加速力矩 / Max. Acceleration Torque	T_{2B}	Nm	2.5 倍額定輸出力矩 2.5 Times of Rated Output Torque
慣性慣量 / Inertia Moment		kg.m ²	37.28 x 10 ⁻⁴
額定出力轉速 / Rated Output Speed		rpm	15
最大輸出轉速 / Max. Output Speed		rpm	21
容許輸入轉速 / Permissible Input Speed		rpm	3,000
背隙 / Backlash Ps	J_i	arcmin	≤ 1
背隙 / Backlash P0	J_i	arcmin	≤ 3
背隙 / Backlash P1	J_i	arcmin	≤ 5
容許徑向力 / Max. Radial Force	F_{2rB}	N	30,000
容許軸向力 / Max. Axial Force	F_{2aB}	N	24,000
額定壽命 / Rated Life	L_H	hr	S5 周期運轉 : >6,000 (S1 連續運轉 : >3,000 hrs) S5 Cycle Operation: >6,000 (S1 Continuous Operation: >3,000 hrs)
扭轉剛性 / Torsional Rigidity		Nm/arcmin	7,400
效率 / Efficiency	η	%	≥ 85
重量 / Weight		kg	

軸套 Bushing

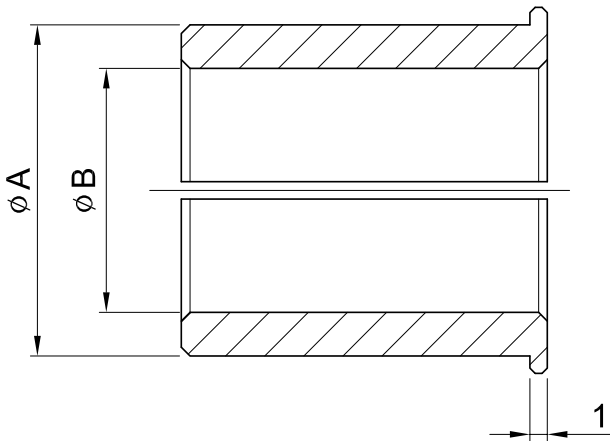

軸套內徑為所使用伺服馬達的輸出軸軸徑。下表中沒有的情況下需要插入軸套。在您所使用的輸出軸軸徑的近似值中選擇大值。
 For motor shaft diameters not listed, gearboxes will be supplied with a bush to suit.
 The bore sizes may be supplied as a larger bore with a bush.

連接軸_孔徑 Shaft Bore ϕB ϕA	8	11	14	19	22	24	28	32	35
6	•	•							
6.35	•								
8		•							
9		•							
10			•						
11			•						
12			•						
12.7			•						
14				•					
15.85				•					
16				•		•	•		
19					•	•	•		
22						•	•	•	
24							•		•
28								•	•
32									•

高精度擺線減速機與馬達安裝指南 CYKODRIVE and Motor Mounting Instructions



核對馬達型號與減速機規格是否正確。並將配合面擦拭乾淨。
Confirm the motor, and gearbox size. Clean up the mounting surface.



如馬達軸徑在 $\varnothing 35$ 以下，請將馬達軸上的鍵拿掉。
Remove the motor key if the diameter of motor shaft is under $\varnothing 35$.



檢查馬達出力軸尺寸，如需軸套，請先裝進入力孔內。
Check motor shaft size and insert bushing into input bore if necessary.



取出塞頭，使用六角板手將迫緊環螺絲鬆開。並將螺絲對準孔位。
Remove the plug on the adapter plate. Rotate the set collar till the bolt is line up.



將馬達垂直裝入減速機。
Put the motor into the gearbox vertically.



依序 1~4 使用扭力板手鎖上外六角螺絲。
Tighten the mounting bolt in 1~4 order with torque wrench.

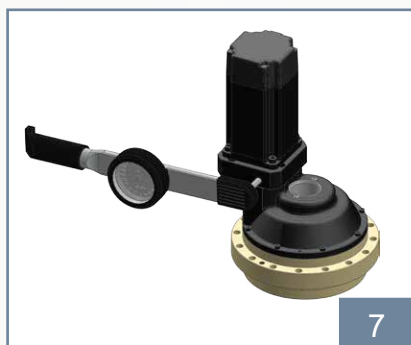

使用扭力板手將迫緊環螺絲鎖緊。
Tighten the set collar bolt with torque wrench.



裝回塞頭。
Tighten back the screw plug.

1. 務必先鎖緊馬達，才能鎖緊馬達軸心迫緊環。
To be sure to tighten motor first and then to tighten the set collar on motor shaft.
2. 請依步驟順序組裝，尤其步驟 5、6 不可顛倒。
Please assembly in order according to above steps, especially for step 5 and step 6.