

ALUMINUM ALLOY WORM REDUCER SERIES

鋁合金蝸輪減速機系列

MODEL : NEOM

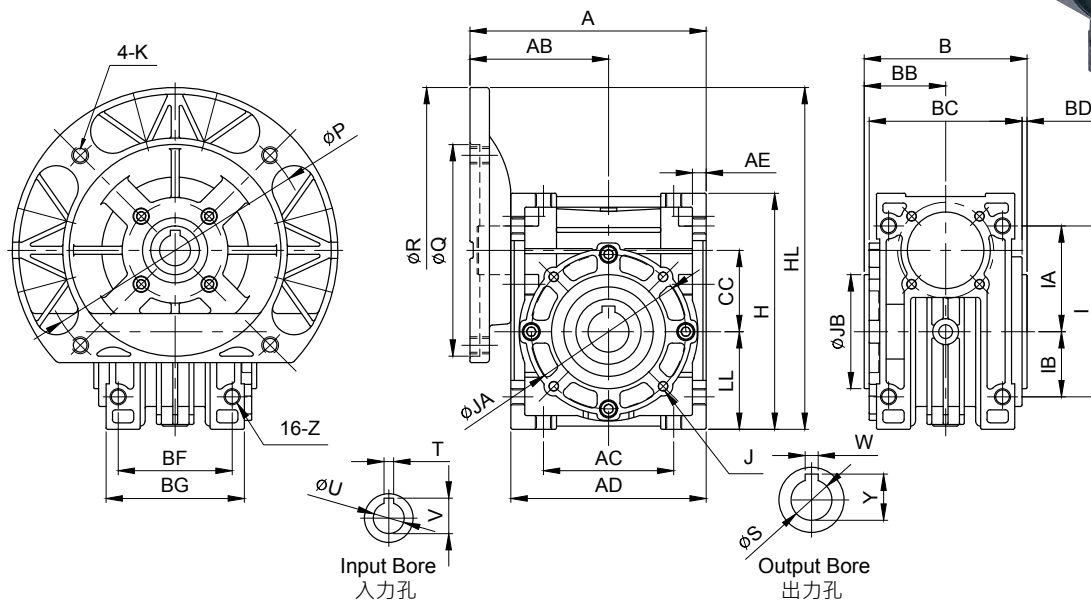
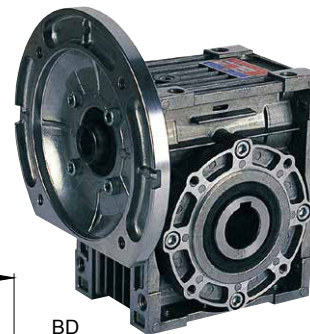

unit: mm

型號 Model	減速比 Ratio	馬力 HP	A	AB	AC	AD	AE	B	BB	BC	BD	BF	BG	CC	LL	H	HL	I	IA	IB	Z
30	5~60	40W·60W	98	58												115					
	5~40	90W	98	58	55	80	6	65	32.5	60	2	45	58	30	40	98	115	72	45	27	M6
	5~30	63B	100	60												140					
40	5~60	63B	125	74	70	102	7.5	88	44	80	2	60	72	40	50	122	170	90	55	35	M8
	5~30	1/2																			
50	5~60	1/4	142	82												190					
	5~50	1/2	142	82	80	120	8.5	98	49	94	3	70	85	50	60	145	190	105	65	40	M10
	5~30	1	148	88												210					
60	5~60	1/2	167	94												215					
	5~50	1	174	101	100	146	10	108	54	102	3	85	102	60	75	180	235	136	83	53	M10
	5~15	2	174	101												235					
70	5~60	1/2	196	111												235					
	5~60	1	198	113	120	170	12	128	64	118	3	90	110	70	85	200	255	150	90	60	M10
	5~40	2	198	113												255					

型號 Model	減速比 Ratio	馬力 HP	馬達盤及入力孔 Motor Flange & Input Bore							出力孔 Output Bore						重量 Weight (kg)						
			P	Q	R	K	V	T	U	W	S	Y	JA	JB	J×牙深 Deep							
30	5~60	40W·60W	104	83	□ 90	M6																
	5~40	90W	104	83	□ 90	M6	12.7	4	11	5	14	16.3	65	55	8-M6-9						1.28	
	5~30	63B	115	95	140	M8																
40	5~60	63B	115	95	140	M8	12.7	4	11													
	5~30	1/2	130	110	160	M8	16.3	5	14	6	20	22.8	77	60	12-M6-9						2.56	
50	5~60	1/4	130	110	160	M8	12.7	4	11													
	5~50	1/2	130	110	160	M8	16.3	5	14	8	25	28.3	95	70	12-M6-9						4.27	
	5~30	1	165	130	200	M10	21.8	6	19													
60	5~60	1/2	130	110	160	M8	16.3	5	14													
	5~50	1	165	130	200	M10	21.8	6	19	8	25	28.3	120	80	12-M8-12						6.41	
	5~15	2	165	130	200	M10	27.3	8	24													
70	5~60	1/2	130	110	160	M8	16.3	5	14													
	5~60	1	165	130	200	M10	21.8	6	19	8	30	33.3	140	90	12-M10-15						9.54	
	5~40	2	165	130	200	M10	27.3	8	24													

選配馬力時，請參考「減速機參數」(第15頁)。 Please refer to page I5 "Reducers Parameter".