

# ALUMINUM ALLOY WORM REDUCER SERIES

## 鋁合金蝸輪減速機系列

MODEL : NEOFM

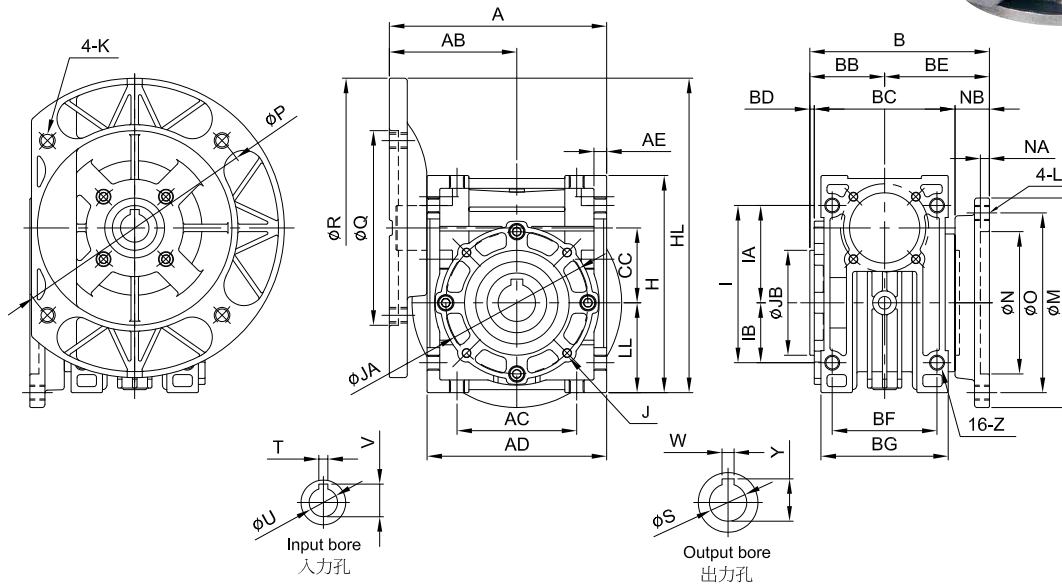

unit: mm

型號 Model	減速比 Ratio	馬力 HP	A	AB	AC	AD	AE	B	BE	NB	BB	BC	BD	BF	BG	CC	LL	H	HL	I	IA	IB	Z
30	5~60	40W·60W	98	58														115					
	5~40	90W	98	58	55	80	6	92.5	60	30	32.5	60	2	45	58	30	40	98	115	72	45	27	M6
	5~30	63B	100	60														140					
40	5~60	63B	125	74	70	102	7.5	114	70	30	44	80	2	60	72	40	50	122	170	90	55	35	M8
	5~30	1/2																190					
50	5~60	1/4	142	82														190					
	5~50	1/2	142	82	80	120	8.5	130	80	33	50	94	3	70	85	50	60	145	190	105	65	40	M10
	5~30	1	148	88														210					
60	5~60	1/2	167	94														215					
	5~50	1	174	101	100	146	10	154	100	49	54	102	3	85	102	60	75	180	235	136	83	53	M10
	5~15	2	174	101														235					
70	5~60	1/2	196	111														235					
	5~60	1	198	113	120	170	12	164	100	41	64	118	3	90	110	70	85	200	255	150	90	60	M10
	5~40	2	198	113														255					

型號 Model	減速比 Ratio	馬力 HP	馬達盤 Motor Flange				入力孔 Input Bore			出力法蘭及出力孔 Output Flange & Output Shaft											重量 Weight (kg)				
			P	Q	R	K	V	T	U	N	NA	O	M	L	W	S	Y	JA	JB	J× 牙深 Deep					
30	5~60	40W·60W	104	83	□ 90	M6																			
	5~40	90W	104	83	□ 90	M6	12.7	4	11	70	5	85	100	M6	5	14	16.3	65	55			4-M6-9	1.58		
	5~30	63B	115	95	140	M8																			
40	5~60	63B	115	95	140	M8	12.7	4	11																
	5~30	1/2	130	110	160	M8	16.3	5	14	80	6	100	120	M8	6	20	22.8	77	60			4-M6-9	2.89		
50	5~60	1/4	130	110	160	M8	12.7	4	11																
	5~50	1/2	130	110	160	M8	16.3	5	14	95	6	120	140	M10	8	25	28.3	95	70			4-M6-9	4.5		
	5~30	1	165	130	200	M10	21.8	6	19																
60	5~60	1/2	130	110	160	M8	16.3	5	14																
	5~50	1	165	130	200	M10	21.8	6	19	130	7	160	180	M10	8	25	28.3	120	80			4-M8-12	7.23		
70	5~15	2	165	130	200	M10	27.3	8	24																
	5~60	1/2	130	110	160	M8	16.3	5	14																
70	5~60	1	165	130	200	M10	21.8	6	19	150	7	185	210	M12	8	30	33.3	140	90			4-M10-15	10.6		
	5~40	2	165	130	200	M10	27.3	8	24																

選配馬力時，請參考「減速機參數」及「馬達規格選配」(第 15 頁)。 Please refer to page I5 "Reducers Parameter" and "Selection of Motor Size".