

# ALUMINUM ALLOY WORM REDUCER SERIES

## 鋁合金蝸輪減速機系列

MODEL : NEO

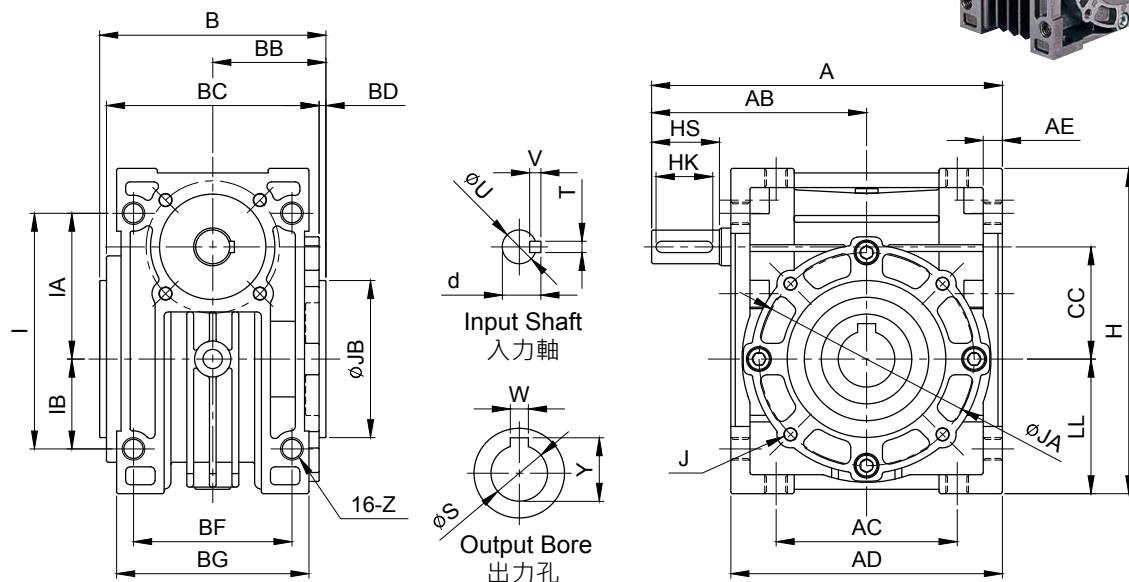

unit: mm

型號 Model	減速比 Ratio	馬力 HP	A	AB	AC	AD	AE	B	BB	BC	BD	BF	BG	CC	LL	H	I	IA	IB	Z
30	5~60	40W·60W	105	65	55	80	6	65	32.5	60	2	45	58	30	40	98	72	45	27	M6
	5~40	90W																		
	5~30	1/4																		
40	5~60	1/4	131	80	70	102	7.5	88	44	80	2	60	72	40	50	122	90	55	35	M8
	5~30	1/2																		
50	5~60	1/4	155	95	80	120	8.5	98	49	94	3	70	85	50	60	145	105	65	40	M10
	5~50	1/2																		
	5~30	1																		
60	5~60	1/2	193	120	100	146	10	108	54	102	3	85	102	60	75	180	136	83	53	M10
	5~50	1																		
	5~15	2																		
70	5~60	1/2	225	140	120	170	12	128	64	118	3	90	110	70	85	200	150	90	60	M10
	5~60	1																		
	5~40	2																		

型號 Model	減速比 Ratio	馬力 HP	入力軸 Input Shaft				出力孔 Output Bore						重量 Weight (kg)
			HS	U	d	TxVxHK	W	S	Y	JA	JB	J×牙深 Deep	
30	5~60	40W·60W	20	11	12.5	4x4x16	5	14	16.3	65	55	8-M6-9	1.16
	5~40	90W											
	5~30	1/4											
40	5~60	1/4	25	12	13.5	4x4x20	6	20	22.8	77	60	12-M6-9	2.2
	5~30	1/2											
50	5~60	1/4	30	15	17	5x5x25	8	25	28.3	95	70	12-M6-9	3.59
	5~50	1/2											
	5~30	1											
60	5~60	1/2	40	18	20.5	6x6x35	8	25	28.3	120	80	12-M8-12	5.8
	5~50	1											
	5~15	2											
70	5~60	1/2	45	22	25	7x7x40	8	30	33.3	140	90	12-M10-15	9.04
	5~60	1											
	5~40	2											

選配馬力時，請參考「減速機參數」(第15頁)。Please refer to page I5 "Reducers Parameter".