

MODEL : NEH

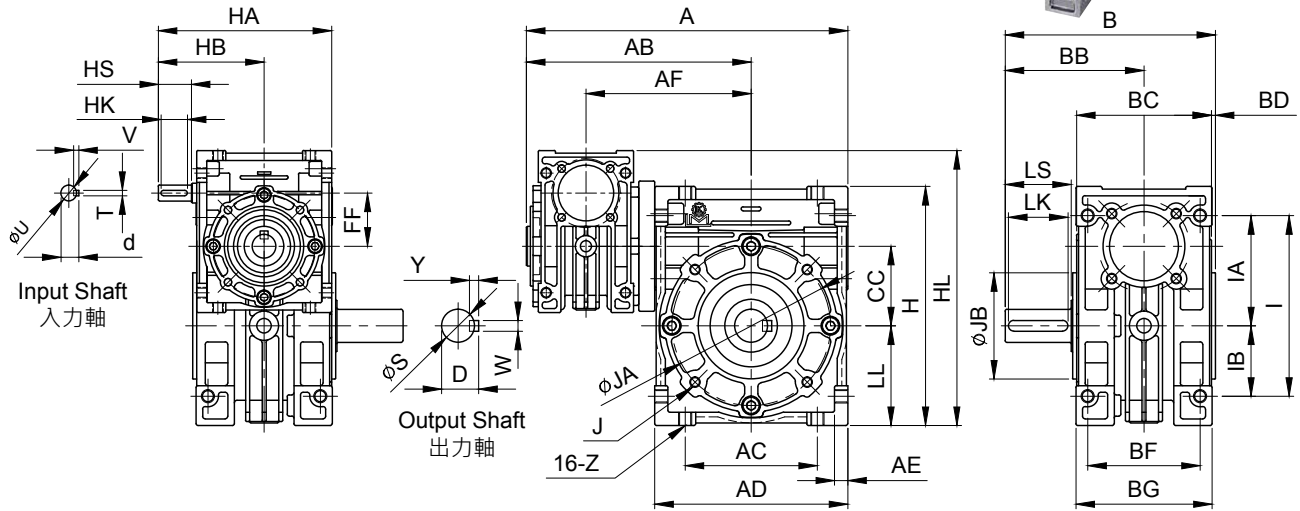
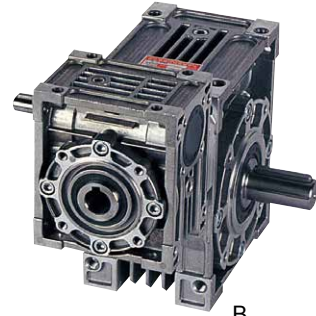

出力段減速機中心距離 (mm) Central distance of output of reducer.	40	50	60	70
入力段減速機中心距離 (mm) Central distance of input of reducer.	30	30	40	50

unit: mm

型號 Model	減速比 Ratio	馬力 HP	CC	FF	A	AB	AC	AD	AE	AF	B	BB	BC	BD	BF	BG	H	HA	HB	HL
40	100~3600	1/8(90W) 63B	40	30	176.5	125.5	70	102	7.5	93	127	85	80	2	60	72	122	105	65	148
50	100~3600	1/8(90W) 63B	50	30	194.5	134.5	80	120	8.5	102	150	100	94	3	70	85	145	105	65	168
60	100~3600	(1/4) 1/2	60	40	243	170	100	146	10	125	159	105	102	3	85	102	180	131	80	207
70	100~3600	(1/4) 1/2 1	70	50	280	195	120	170	12	145	187	125	118	3	90	110	200	155	95	240

型號 Model	減速比 Ratio	馬力 HP	I	IA	IB	LL	Z	入力軸 Input Shaft				出力軸 Output Shaft							重量 Weight (kg)
								HS	U	d	TxVxHK	LS	S	D	WxYxLK	JA	JB	Jx 牙深 Deep	
40	100~3600	1/8(90W) 63B	90	55	35	50	M8	20	11	12.5	4x4x16	40	20	22.5	6x6x35	77	60	12-M6-9	3.86
50	100~3600	1/8(90W) 63B	105	65	40	60	M10	20	11	12.5	4x4x16	50	25	28	8x7x45	95	70	12-M6-9	5.41
60	100~3600	(1/4) 1/2	136	83	53	75	M10	25	12	13.5	4x4x20	50	25	28	8x7x45	120	80	12-M8-12	8.3
70	100~3600	(1/4) 1/2 1	150	90	60	85	M10	30	15	17	5x5x25	60	30	33	8x7x55	140	90	12-M10-15	13.95

雙段減速機以定轉速為設計，最大扭力請參考「減速機參數」(第 15 頁)，( ) 為較安全選配馬力。

This 2-stage worm reducer is designed to rotate at fixed speed. We recommend to choose the HP inside ( ) for safer choice. Please refer to page I5 "Reducers Parameter."