

**MODEL : CADW**



▲ 75#



▲ 75A#

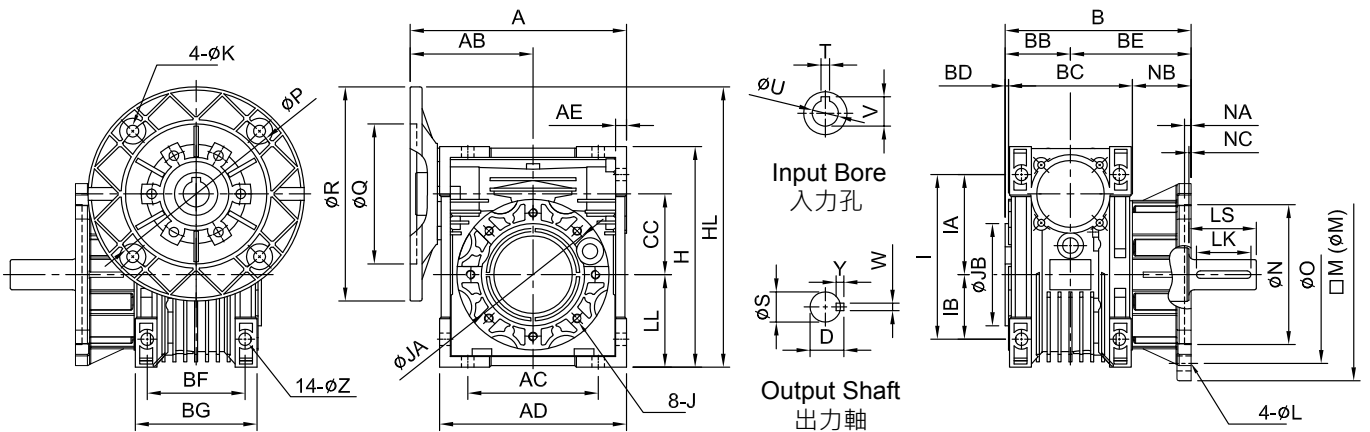

unit: mm

型號 Model	減速比 Ratio	馬力 HP	A	AB	AC	AD	AE	B	BE	NB	NC	BB	BC	BD	BF	BG	CC	LL	H	HL	I	IA	IB	Z
75 75A	7.5~60	1	199	113	120	172	10	171 185	111 125	54 68	2	60	114	3	90	112	75	86	205	261	153	93	60	11.5
75 75A	7.5~60	2	199	113	120	172	10	171 185	111 125	54 68	2	60	114	3	90	112	75	86	205	261	153	93	60	11.5
75 75A	7.5~15	3	200	114	120	172	10	171 185	111 125	54 68	2	60	114	3	90	112	75	86	205	286	153	93	60	11.5

型號 Model	減速比 Ratio	馬力 HP	馬達盤及入力孔 Motor Flange & Input Bore							出力法蘭及出力軸 Output Flange & Output Shaft											重量 Weight (kg)	
			P	Q	R	K	V	T	U	N	NA	O	M	L	LS	S	D	WxYxLK	JA	JB		Jx 牙深 Deep
75 75A	7.5~60	1	165	130	200	11	21.8	6	19	130	6	165 160	169 185	14 11	62	25	28	7x7x50	115	95	M8-12	9.8
75 75A	7.5~60	2	165	130	200	11	27.3	8	24	130	6	165 160	169 185	14 11	62	28	31	7x7x50	115	95	M8-12	9.8
75 75A	7.5~15	3	215	180	250	13	31.3	8	28	130	6	165 160	169 185	14 11	62	28	31	7x7x50	115	95	M8-12	10

選配馬力時，請參考「減速機參數」(第 I24 頁)。 Please refer to page I24 "Reducers Parameter".