

Preview

[2023]



微型齒輪減速機

Compact Gearmotor Series

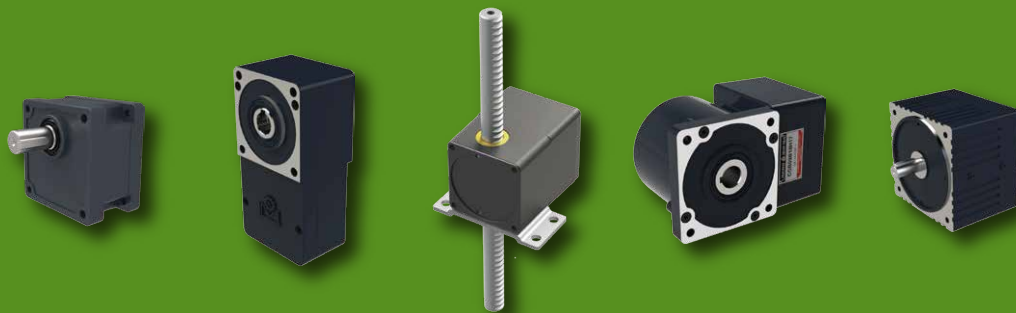

【 傳動裝置的解決方案 / 減速機的領導品牌 】

LI MING MACHINERY CO., LTD.

Compact Gearmotor Series

微 型 齒 輪 減 速 機

前言 時勢造英雄

科技的進步，產品的小型化似乎成為了一種趨勢。利茗機械股份有限公司自 1969 創立以來，一直以生產大型減速機為主，至 1992 年開始生產小型減速機。利茗公司秉持著多年的專業製造經驗，現在推出微型減速機，使得公司產品型號更齊全，提供機械相關產業更完整的服務。

Foreword - The trend makes the hero.

Technical advancement and miniaturized products have become a trend. Since our establishment in 1969, LI MING Machinery CO., LTD. has been dedicated to the production of large speed reducers. From 1992, we started production of small speed reducers. By adhering to professional manufacturing experience for several years, now LI MING Company has introduced compact-size speed reducers, making a more complete range of our products, providing better service to compact gearmotor series related machine industry.

使用

行業別	Application		
輸送機械類 Conveyors	電子儀器類 Electronic Instruments	食品機械類 Food Processing Machines	事務機械類 Business Machines
包裝機械類 Packing Machines	電線電纜類 Wires and Cables	印刷機械類 Printing Machines	金融業設備 Facilities for Financial Institutes
醫療儀器類 Medical Instruments	環保設備類 Environmental Protection Equipment	紡織機械類 Textile Machines	理化儀器類 Physical & Chemical Instruments
工作母機類 Working Center	自動販賣類 Automatic Vending Machines		



目次

微型減速機 Compact Reducer	2	離合剎車器 Clutch Brake	92
微型馬達 Compact Motor	8	DC 有刷馬達 DC Motor	94
● 單相感應式馬達 Single-Phase Induction Motor	15	平行式中空軸減速機 Hollow Shaft Gear Reducer	98
● 三相感應式馬達 3-Phase Induction Motor	27	強力型齒輪減速機 Powerful Reducer	100
● 單相可逆式馬達 Single-Phase Reversible Motor	37	直線減速機 Linear Reducer	103
● 三相可逆式馬達 3-Phase Reversible Motor	49	鋁合金蝸輪減速機 Aluminum Alloy Worm Reducer	112
● 速度控制器 Indication of Model Numbers	58		
● 單相感應調速馬達 Single-Phase Induction Speed Variable Motor	63		
● 單相可逆調速馬達 Single-Phase Reversible Speed Variable Motor	75		
● 電磁剎車馬達 Electromagnetic Brake Motor	86		



品質至上 · 顧客滿意
Quality Supreme & Customer's Satisfaction

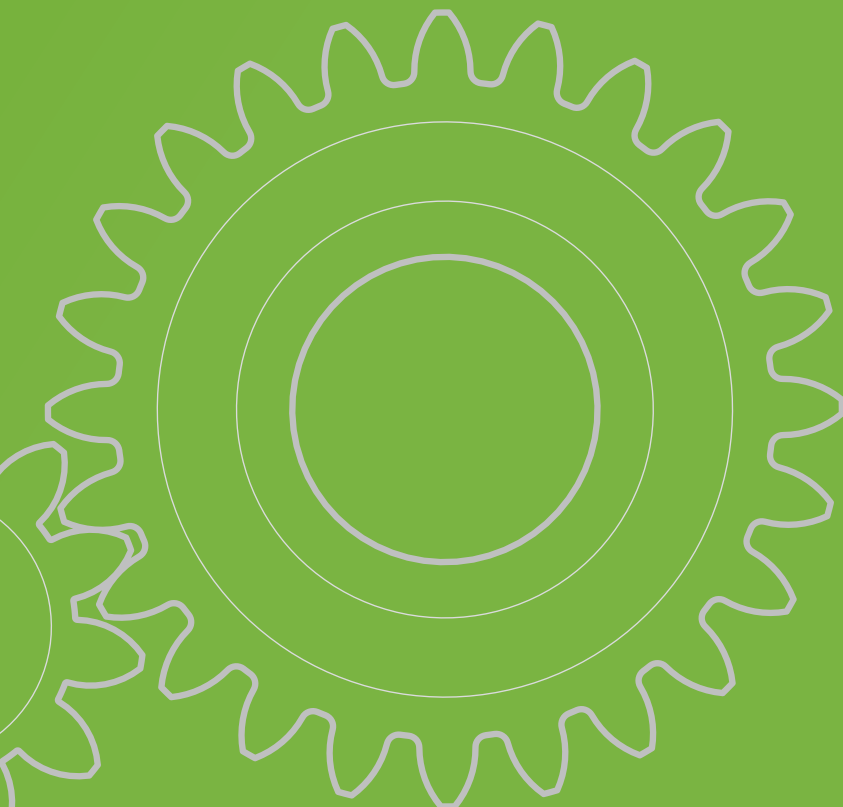

微型減速機 Compact Reducer



Indication of Model Numbers

機種型號表示

CG	09	B	50	S12
機型 Type	型號 Model	軸承型式 Bearing	減速比 Ratio	出力軸 Output Shaft
CGB	06 : 60mm	B : 滾珠軸承 Ball bearing		S : 實心軸 Solid Output Shaft
CGU	07 : 70mm	M : 含油軸承 Metal bearing		H : 中空軸 Hollow Shaft
CGCU	08 : 80mm 09 : 90mm	F : 滾珠 + 含油 Balls only for outputs shaft, rest are metal.		

減速機速比一覽表 List of Reducer Ratio

機種 Model	減速機速比 Reducer Ratio
CG06 □ S8	3、5、6、7.5、9、12.5、15、18、25、30、36、50、60、75、90、100、120、150、180、200、240、300
CG07 □ S10	3、5、6、7.5、9、12.5、15、18、25、30、36、50、60、75、90、100、120、150、180、200、240
CG08 □ S10	3、5、6、7.5、9、12.5、15、18、25、30、36、50、60、75、90、100、120、150、180、200、240、300
CG08 □ X	10、15
CG09 □ S12	3、5、6、7.5、9、12.5、15、18、25、30、36、50、60、75、90、100、120、150、180、200、240
CG09 □ X	10、15
CG09 □ S15	3、5、6、7.5、9、12.5、15、18、25、30、36、50、60、75、90、100、120、150、180、200、240
CGB09B □ H17	9、15、18、22.5、27、37.5、45、54、75、90、108、150、180、225
CGB09B □ H18	9、15、18、22.5、27、37.5、45、54、75、90、108、150、180、225

容許懸吊荷重及容許推力荷重 Permissible Overhung Load and Permissible Thrust Load

- ◆ 與減速機出力軸呈直角方向且在出力軸 1/2 處，施以最大荷重時，稱為容許懸吊荷重。(如下圖示)
- ◆ 與減速機出力軸呈平行方向施以荷重，稱為推力荷重。(如下圖示)
- ◆ When a maximum load is applied vertical at the point of 1/2 output shaft and gear reducer; it is called permissible overhung load. (See diagram below)
- ◆ When a load is applied in parallel direction to the output shaft of speed reducer, it is called thrust load. (See diagram below)

型號 Model	容許懸掛荷重 Permissible Overhung load (kg)	容許推力荷重 Permissible Thrust Load (kg)
CG06B CG06M	15 8	3
CG07B CG07M	25 15	4
CG08B CG08M	35 25	5
CG09B CG09M	45 35	10

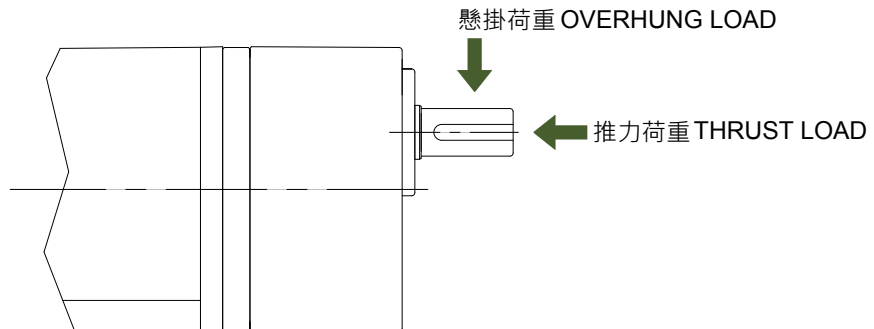

減速機傳動效率 Gear Reducer Transmission Efficiency

型號 Model	3	5	6	7.5	9	12.5	15	18	25	30	36	50	60	75	90	100	120	150	180	200	240	300
CG06B □	81%				73%				66%													
CG07B □	81%				73%				66%													
CG08B □	81%				73%				66%													
CG09B □	81%				73%				66%													

減速機之選定 Selection of Gear Reducer

減速比計算公式

客戶依減速機輸出迴轉速和配合之機械迴轉速而選擇最適合的減速比。(定轉速)

$$i = Nm \div Ng \text{ or } 1 \div i = Ng \div Nm$$

i: 減速比

Ng: 減速機轉速 (RPM)

Nm: 馬達轉速 (RPM)

直接連結減速機之轉矩計算公式

客戶依減速機輸出轉矩和配合之機械轉矩而選擇最合適的型號。(定轉矩)

$$Tg = Tm \times i \times \eta$$

Tg: 減速機輸出轉矩

Tm: 馬達輸出轉矩

i: 減速比

η : 減速機傳動效率

最大容許轉矩

減速機輸出轉矩是右上述之轉矩計算公式算出，當減速比較大時受到齒輪材質、齒箱材質及減速機本身的設計結構等限制下，所能承受的負載轉矩有限，因此各個型號皆有最大容許轉矩的限制。(如下圖)

General Introduction of Speed Reducer Series Calculation of Reduction Gear Ratio

Customers choose the most appropriate reduction gear ratio according to their requirement to match output rpm of gear reducer with the rpm of operating machines. (AAC)

$$i = Nm \div Ng \text{ or } 1 \div i = Ng \div Nm$$

i: Gear ratio

Ng: Output speed of gear reducer (RPM)

Nm: Motor running speed (RPM)

Torque Calculation Formula of Direct Link Speed Reducer

Customer chooses the most appropriate model to suit the machine's output torque of the speed reducer. (Constant torque)

$$Tg = Tm \times i \times \eta$$

Tg: Reducer output torque

Tm: Motor output torque

i: Gear ratio

η : Speed reducer transmission efficiency

Maximum permissible torque

Output torque of speed reducer is calculated according to the formula described above.

When reduction ratio is larger, its withstanding load torque is limited, due to restrictions of the gearbox quality and the structural design of the speed reducer itself. Therefore, all models have the restriction of their maximum permissible torque. (See diagram below.)

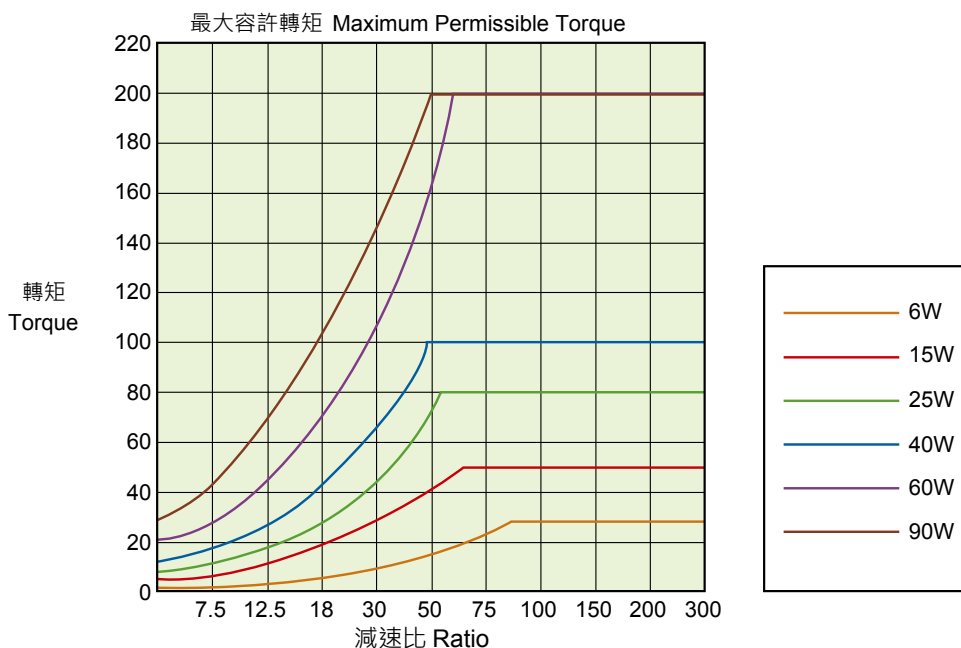

■ 微型減速機分解系統圖 Compact Reducer System Drawing

MODEL : CG

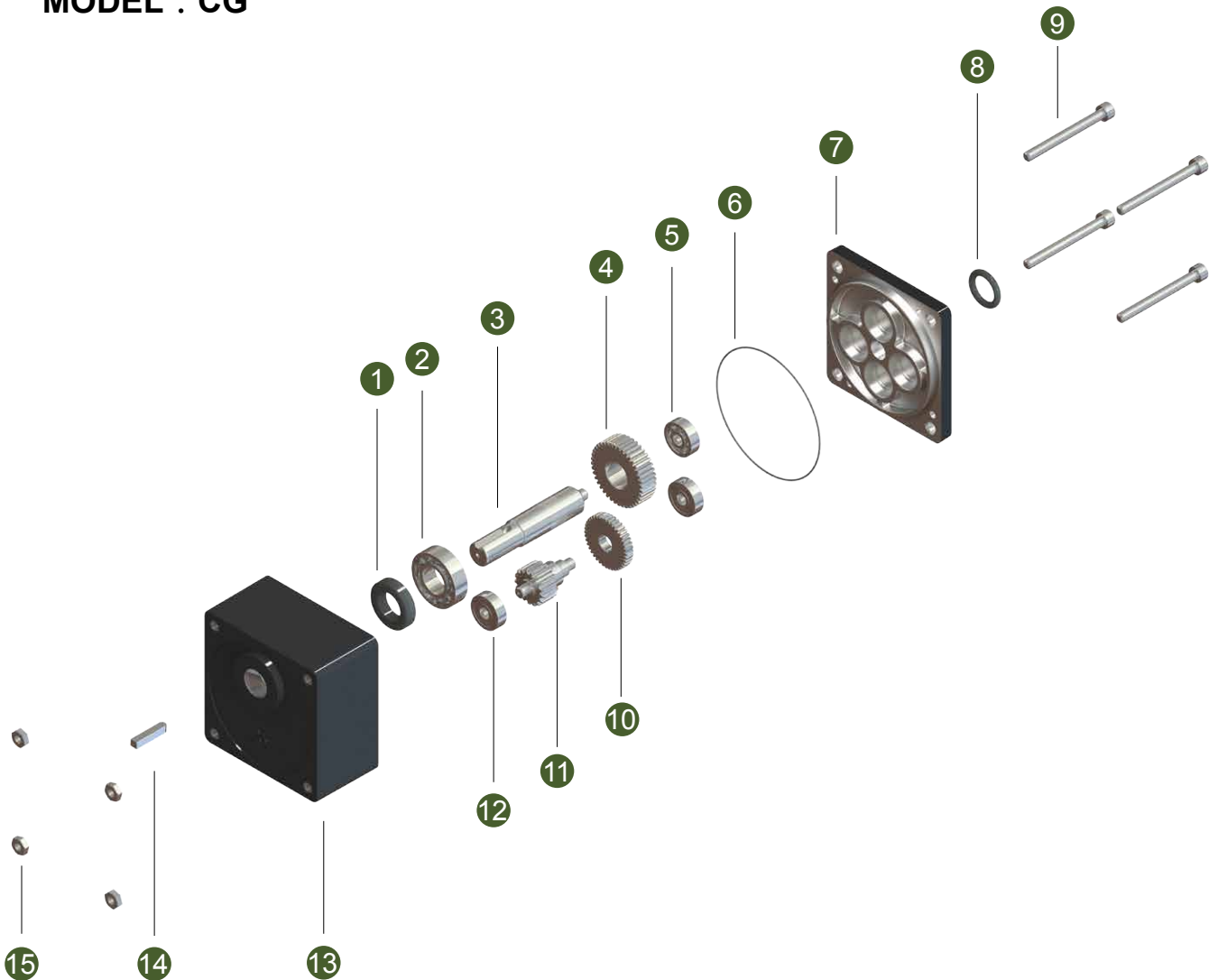

No.	名稱	Name of Part	No.	名稱	Name of Part
1	油封	Oil Seal	9	六角承窩頭螺絲	Hex. Screw
2	滾珠軸承	Ball Bearing	10	B 齒輪	B Gear
3	出力軸	Output Shaft	11	C 齒輪	C Gear
4	D 齒輪	D Gear	12	滾珠軸承	Ball Bearing
5	滾珠軸承	Ball Bearing	13	齒輪箱	Gearbox
6	O 型環	O-Ring	14	單圓鍵	Key
7	後蓋	Rear Cover	15	外六角螺帽	HEX. Nut
8	O 型環	O-Ring			

■ 微型減速機分解系統圖 Compact Reducer System Drawing

MODEL : CGB

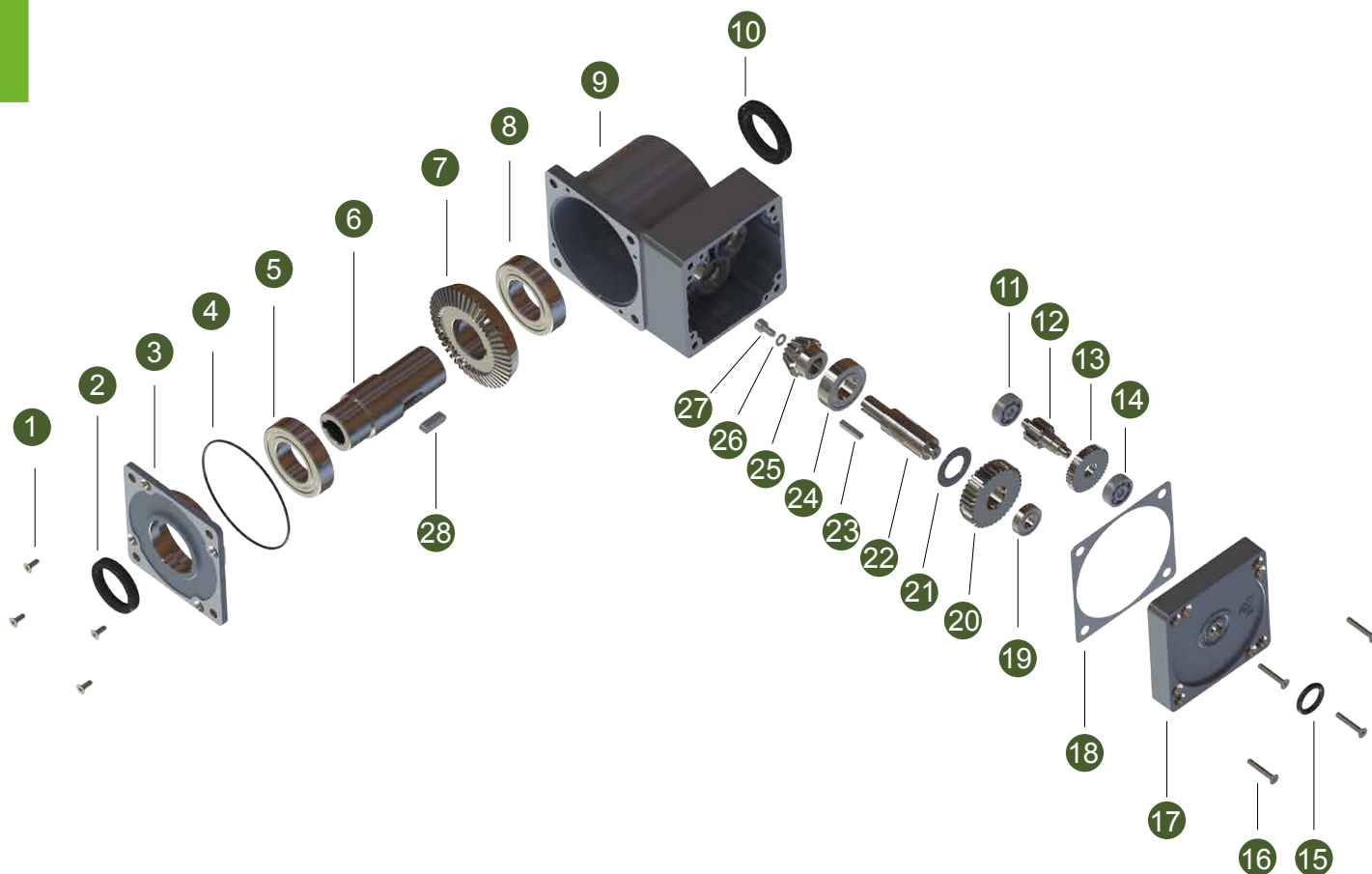

No.	名稱	Name of Part	No.	名稱	Name of Part
1	皿頭螺絲	Pan Head Screws	15	O 型環	O Ring
2	油封	Oil Seal	16	皿頭螺絲	Pan Head Screws
3	上蓋	Top Cover	17	後蓋	Rear Cover
4	O 型環	O Ring	18	非石棉墊片	Asbestos Free Gasket
5	滾珠軸承	Ball Bearing	19	滾珠軸承	Ball Bearing
6	出力軸	Output Shaft	20	D 齒輪	D Gear
7	傘齒輪	Bevel Gear	21	平面滑司	Flat Washer
8	滾珠軸承	Ball Bearing	22	連接軸	
9	齒輪箱	Gear Shell	23	鍵	Key
10	油封	Oil Seal	24	滾珠軸承	Ball Bearing
11	滾珠軸承	Ball Bearing	25	傘齒輪	Bevel Gear
12	C 齒輪	C Gear	26	平面滑司	Flat Washer
13	B 齒輪	B Gear	27	六角承窩頭螺絲	HEX. Screw
14	滾珠軸承	Ball Bearing	28	鍵	Key

MODEL : CG

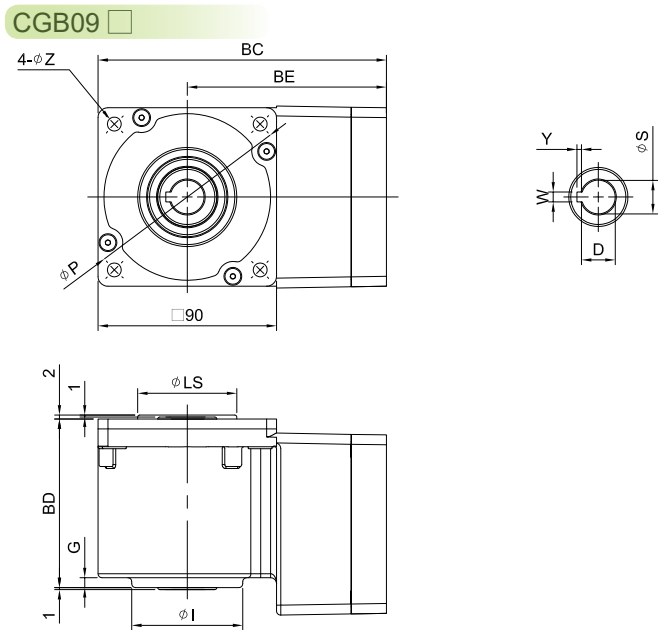
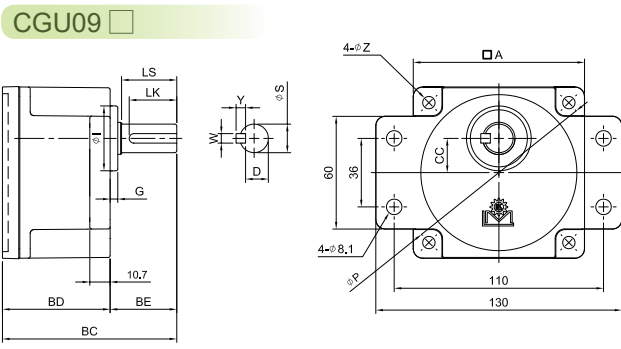
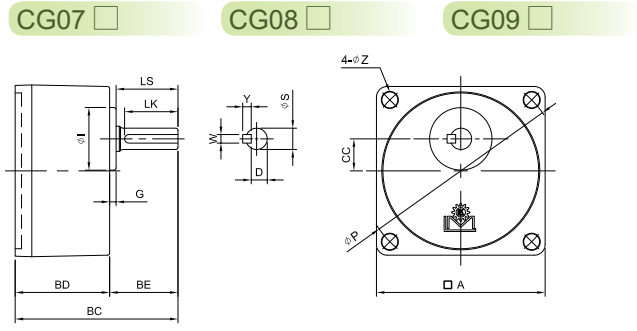
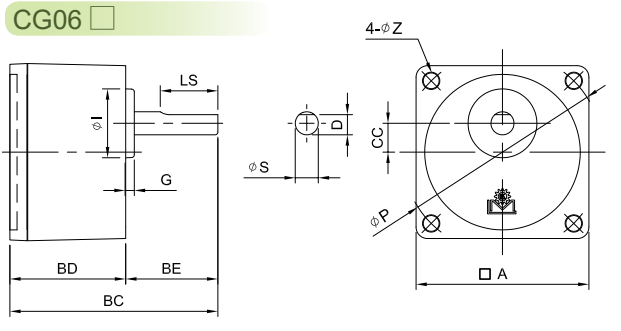

unit: mm

型號 Model	動力 Power	減速比 Ratio	A	CC	BC	BD	BE	I	G	P	Z	出力軸 Output Shaft				重量 Weight (kg)
												LS	S	D	WxYxLK	
06	6W	5~75 90~300	60	10	72.2	40.2	32	24	3	70	M4	20	8	7	-	0.34
					78.2	46.2										0.39
07	15W	5~75 90~240	70	15	74	42	32	27	3	82	M5	29	10	7.5	4x4x25	0.52
					80	47										0.58
08	25W	5~75 90~300	80	15	76.3	44.3	32	29	3	94	M5	27	10	7.5	4x4x25	0.66
					83.3	51.3										0.81
09	40W~90W	5~75 91.57~240	90	18	91.6	56.6	35	36	4	104	M6	29	12	8.5	4x4x25	1.2
					100.6	65.6										1.4
GU09	90W	5~75 91.57~240	90	18	91.6	56.6	35	34	4	104	M6	29	12	8.5	4x4x25	1.2
					100.6	65.6							15	12	5x5x25	1.4
GB09	90W	9~225	90	18	145.4	85	100.4	56	5	104	M6	50	17	13.3	5x5x25	1.5
														14.3		

微型馬達 Compact Motor



Indication of Model Numbers

機種型號表示

CM	09	I	G	40	SA	T
機型 Type	型號 Model	馬達型式 Motor Type	出力軸 Output Shaft	輸出功率 Output Power	電壓級數 Voltage	附件 Accessory
CM	06 : 60mm 07 : 70mm 08 : 80mm 09 : 90mm	I : 感應式 Induction R : 可逆式 Reversible	A : 圓柱軸 Cylindrical Shaft G : 螺旋齒 Helical Gear Shaft	06 : 6W 15 : 15W 25 : 25W 40 : 40W 60 : 60W 90 : 90W	SA:1 Ø 110V 4P SB:1 Ø 220V 4P SD:1 Ø 240V 4P TB:3 Ø 220V 4P TD:3 Ø 240V 4P TC:3 Ø 380V 4P TJ: 3 Ø 220V/380V 4P TH: 3 Ø 415V 4P TN: 3 Ø 440V 4P TK: 3 Ø 480V 4P TM:3 Ø 220V/440V 4P	T: 鋁端子盒 Aluminum Terninal Box T1: 大端子盒 Big Terninal box B: 電磁剎車 Electromagnetic Brake F: 風扇 Fan CF: 強制風扇 Compulsory Fan V: 調速型 Speed Variable W: 溫控開關 Tem perature Control Switch

馬達機種一覽表 List of Motor Model

馬達種類 Motor Type	輸出功率 Output Power	安裝尺寸 Installation Measurement	導線型 Conductive Wire Type	端子盒 Terminal Box	單相 Single Phase 50/60Hz 100V/110V	單相 Single Phase 50/60Hz 220V/230V	三相 50/60Hz 200V/220V/380V Three Phase
感應馬達 Induction motor	6W	<input type="checkbox"/> 60mm	●	-	●	●	-
	15W	<input type="checkbox"/> 70mm	●	-	●	●	●
	25W	<input type="checkbox"/> 80mm	●	●	●	●	●
	40W	<input type="checkbox"/> 90mm	●	●	●	●	●
	60W	<input type="checkbox"/> 90mm	●	●	●	●	●
	90W	<input type="checkbox"/> 90mm	●	●	●	●	●
可逆馬達 Reversible motor	6W	<input type="checkbox"/> 60mm	●	-	●	●	-
	15W	<input type="checkbox"/> 70mm	●	-	●	●	●
	25W	<input type="checkbox"/> 80mm	●	●	●	●	●
	40W	<input type="checkbox"/> 90mm	●	●	●	●	●
	60W	<input type="checkbox"/> 90mm	●	●	●	●	●
	90W	<input type="checkbox"/> 90mm	●	●	●	●	●
電磁煞車 馬達 Electromagnetic brake motor	6W	<input type="checkbox"/> 60mm	●	-	●	●	-
	15W	<input type="checkbox"/> 70mm	●	-	●	●	-
	25W	<input type="checkbox"/> 80mm	●	-	●	●	●
	40W	<input type="checkbox"/> 90mm	●	-	●	●	●
	60W	<input type="checkbox"/> 90mm	●	-	●	●	●
	90W	<input type="checkbox"/> 90mm	●	-	●	●	●
組合型 調速馬達 Combinated speed uaridde motor	6W	<input type="checkbox"/> 60mm	●	-	●	●	-
	15W	<input type="checkbox"/> 70mm	●	-	●	●	-
	25W	<input type="checkbox"/> 80mm	●	-	●	●	-
	40W	<input type="checkbox"/> 90mm	●	-	●	●	-
	60W	<input type="checkbox"/> 90mm	●	-	●	●	-
	90W	<input type="checkbox"/> 90mm	●	-	●	●	-
分離型 調速馬達 Separated variable motor	6W	<input type="checkbox"/> 60mm	●	-	●	●	-
	15W	<input type="checkbox"/> 70mm	●	-	●	●	-
	25W	<input type="checkbox"/> 80mm	●	-	●	●	-
	40W	<input type="checkbox"/> 90mm	●	-	●	●	-
	60W	<input type="checkbox"/> 90mm	●	-	●	●	-
	90W	<input type="checkbox"/> 90mm	●	-	●	●	-

註：其他機型陸續開發中。 Note: New models will be available soon.

選配件一覽表 List of Optional Accessory

輸出功率 Output Power	安裝尺寸 Installation Measurement	電壓相數 Phase Voltage	附端子盒 (T) With Terminal Box	電磁煞車 (B) Electromagnetic Brake	調速 (V) Speed Adjustment	溫控開關 (W) Temperature Control Switch	強制風扇 (CF) Compulsory Fan	一般風扇 (F) Regular Fan
6W	<input type="checkbox"/> 60mm	1Ø 單相 110V、220V	-	●	●	●	-	-
15W	<input type="checkbox"/> 70mm	1Ø 單相 110V、220V	-	●	●	●	-	-
25W	<input type="checkbox"/> 80mm	1Ø 單相 110V、220V	●	●	●	●	-	●
		3Ø 三相 220V、380V	●	●	-	●	●	
40W	<input type="checkbox"/> 90mm	1Ø 單相 110V、220V	●	●	●	●	●	●
		3Ø 三相 220V、380V	●	●	-	●	●	
60W	<input type="checkbox"/> 90mm	1Ø 單相 110V、220V	●	●	●	●	●	●
		3Ø 三相 220V、380V	●	●	-	●	●	
90W	<input type="checkbox"/> 90mm	1Ø 單相 110V、220V	●	●	●	●	●	●
		3Ø 三相 220V、380V	●	●	-	●	●	

註 1：電磁刹車器的輸入電源為單相 110V 及單相 220V 兩種。

註 2：60W 馬達與 90W 馬達之標準品已附一般風扇。

註 3：強制風扇的輸入電源為單相 110V 及單相 220V 兩種。

註 4：其他機型陸續開發中。

Note1: The input power of electromagnetic brake has 2 choices ; single phase 110V and single phase 220V.

Note2: The regular fan has attached to 60W and 90W motor as standard product.

Note3: The input power of forced fan has 2 choices; single phase 110V and single phase 220V.

Note4: New models will be available soon.

馬達箱分解系統圖 Motor System Drawing

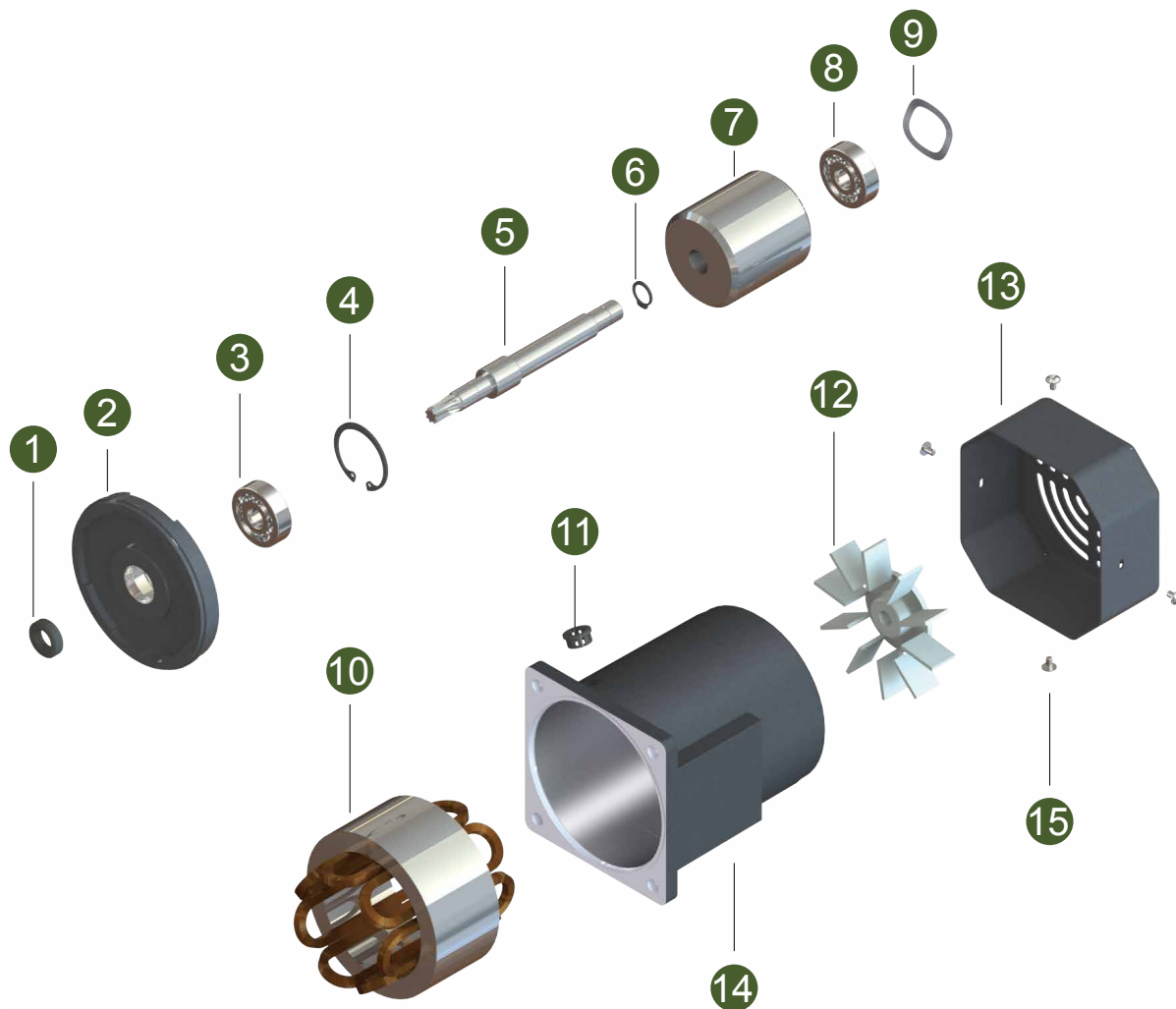

No.	名稱	Name of Part	No.	名稱	Name of Part
1	油封	Oil Seal	9	波型華司	Wave-Washer
2	馬達前蓋	Motor Bracket	10	定子線圈	Stator
3	滾珠軸承	Ball Bearing	11	護線扣環	Cable Retaing Ring
4	R 扣環	R-Ring	12	風扇	Fan
5	馬達齒軸	Motor Gear shaft	13	風罩	Fan Guard
6	S 扣環	S-Ring	14	馬達機殼	Motor Housing
7	轉子	Rotor	15	華司面螺絲	Wusi Screws
8	滾珠軸承	Ball Bearing			

馬達用詞解釋 Motor Terminology

額定

額定是規定馬達的使用限度，包括馬達的輸出功率、電壓、電流、頻率、轉矩及轉速等。
若以溫度上升情況來說，又分成連續額定和短時間額定二種。

連續額定和短時間額定

連續額定是指在馬達在額定輸出情況下連續運轉；而短時間額定是指在規定時間內馬達以額定輸出運轉。

輸出功率

表示馬達在一個單位時間內所能做的功，馬達所做的功是由轉速及轉矩來決定。參考公式如下：

$$\text{輸出 (kW)} = (T \times N) \div 97400$$

T: 轉矩 (kgf·cm) N: 轉速 (RPM)

$$1\text{HP} = 0.746\text{kW}$$

97400: 常數

啟動轉矩

馬達啟動時瞬間發出的轉矩，當負載大於這項轉矩時，馬達將無法啟動。

最大轉矩

於規定的電壓及頻率下能發揮的最大轉矩，馬達運轉時當負載大於這項轉矩時，馬達將立即停止。

額定轉矩

於額定轉速時的轉矩為額定轉矩。

同步轉速

馬達的頻率、極數可以決定馬達的轉速。

參考公式如下：

$$N_s = (120 \times f) \div P$$

N_s : 同步轉速 (RPM)

120: 常數

f: 頻率 (Hz)

P: 極數

例如：4 極的馬達、頻率 60Hz 的同步轉速

$$N_s = (120 \times 60) \div 4 = 1800\text{RPM}$$

無載轉速

馬達在無負載情況下的轉速。

轉差率

屬轉速表示方法之一，參考公式如下：

$$S = (N_s - N) \div N_s$$

S: 轉差率

N_s : 同步轉速 (RPM)

N: 任意負載下的轉速 (RPM)

P: 極數

Rating

Rating is specification of the operating limit of motor, including motor's output power, voltage, current, frequency, torque and RPM, etc. In terms of temperature rise, there are two types, continuous rating and short period rating.

Continuous Rating And Short-Period Rating

Continuous rating refers to continuous operation of the motor under rated output; short-period rating refers to motor running at rated output within a specified period of time.

Output Power

Indicates the power that can be performed by a motor within a unit time. The power performed by the motor is determined by RPM and torque. Reference formula is as below:

$$\text{Output (kW)} = (T \times N) \div 97400$$

T: Torque(kgf·cm) N: RPM

$$1\text{HP} = 0.746\text{kW}$$

97400: Constant

Starting Torque

The torque is produced instantly when motor is started. The motor will not start in case a load is larger than such a torque.

Maximum Torque

The maximum torque performed under the specified voltage frequency. The motor will stop operating immediately when the load is larger than this torque.

Rated Torque

The torque at rated RPM is the rated torque.

Synchronous RPM

Motor frequency and poles can decide motor RPM. Reference formula is as follows:

$$N_s = (120 \times f) \div P$$

N_s : Synchronous RPM

120: Constant

f: Frequency (Hz)

P: Poles

For example:

Synchronous RPM if 4-pole motor, frequency 60Hz

$$N_s = (120 \times 60) \div 4 = 1800\text{RPM}$$

No-load RPM

Motor RPM without load.

Slip

One of the methods to indicate RPM, reference formula as below:

$$S = (N_s - N) \div N_s$$

S: Slip

N_s : Synchronous RPM

N: RPM under and load

P: Poles

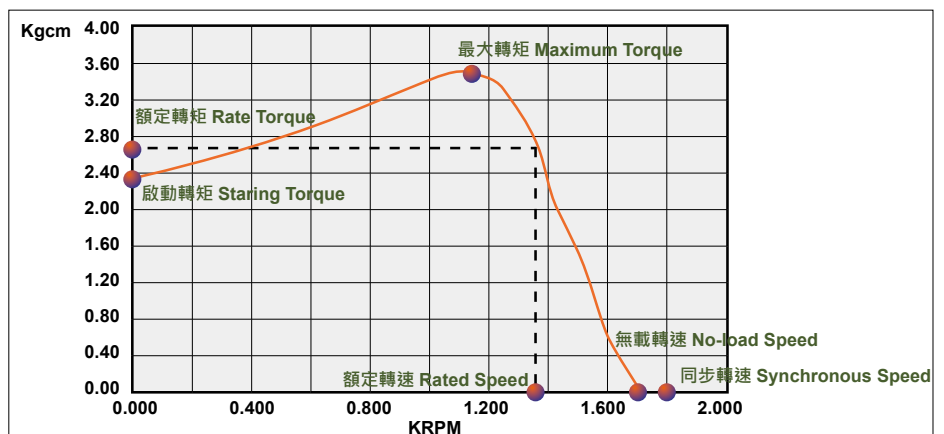

馬達容量基本計算 Basic Calculation of Motor Capacity

皮帶傳送機 Belt Conveyor

空轉動力 Idling Power

$$P_1 = 9.8\mu\omega v l n [W]$$

$$P_g = (P_1 + P_2 + P_3) \frac{100}{n} [W]$$

水平動力 Horizontal Power

$$P_2 = \frac{\mu Q l}{367} [W]$$

垂直動力 Vertical Power

$$P_3 = \pm \frac{QH}{367} [W]$$

P_g : 所需動力 (W)

l : 傳送機之機長 (軸間距離) (m)

ω : 皮帶單位長之重量 (Kg-m)

μ : 摩擦係數

v : 皮帶速度 (m/sec)

Q : 輸送量 (kg/h)

n : 效率 (%)

H : 傾斜傳送機兩端之高低差 (m)

P_g : Required power (W)

l : Length of conveyor (Distance between shafts) (m)

ω : Weight of unit length of belt (Kg/m)

μ : Friction coefficient

v : Belt speed (m/sec)

Q : Conveyance volume (Kg/h)

n : Efficiency (%)

H : Difference in height between two ends of conveyor (m)

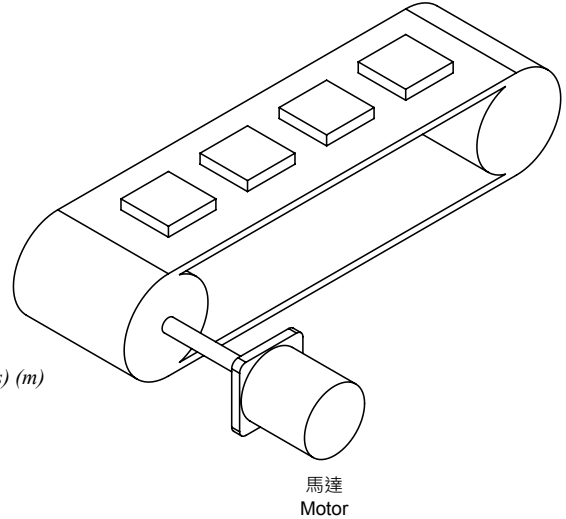

將荷重捲上的場合

Field of Lifting Up The Loading

$$P_g = \frac{\omega v}{6.12} \times \frac{100}{n} [W]$$

P_g : 所需動力 (W)

ω : 荷重 (Kg)

v : 速度 (m/sec)

n : 效率 (%)

P_g : Required power (W)

ω : Load (kg)

v : Speed (m/sec)

n : Efficiency (%)

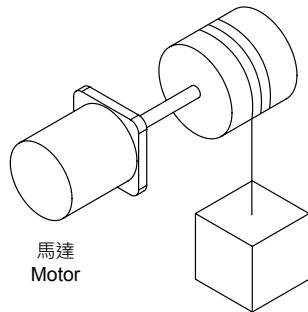

驅動慣性體の場合

Field of Driving Inertia Body

$$P_g = 1.027 N T [W]$$

$$T = \frac{GD^2}{375} \times \frac{N}{t} (Kg-m)$$

P_g : 所需動力 (W)

N : 每分鐘回轉數 (RPM)

T : 轉矩 (Kg-m)

GD^2 : 飛輪效應 (Kg-m²)

(含轉子的飛輪效應)

t : 起動時間 (sec)

P_g : Required power (W)

N : Revolutions per minute (RPM)

T : Torque (Kg-m)

GD^2 : Flywheel effect (including flywheel effect of rotor) (Kg-m²)

t : Starting time (sec)

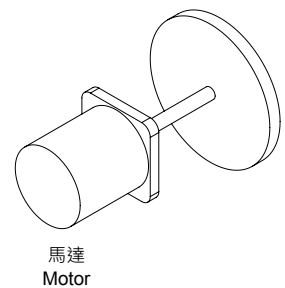

接觸面上做水平移動の場合

Field of Level Movement on Contact Surface

$$P_g = \frac{\mu\omega v}{6.12} [W]$$

P_g : 所需動力 (W)

ω : 荷重 (Kg)

v : 速度 (m/min)

μ : 摩擦係數

P_g : Required power (W)

ω : Load (kg)

v : Speed (m/min)

μ : Friction coefficient

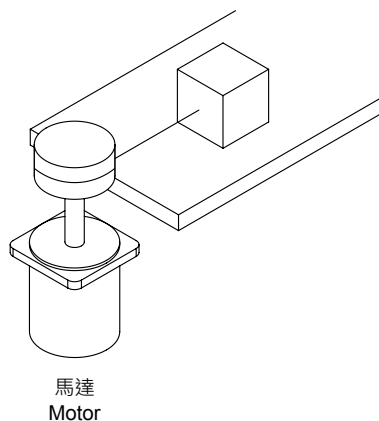

註：以上為常態的基本公式，在實際運用上請依設計物件的安全度、電源的變動及實際的起動加速、負荷大小的影響程度加以選擇。

Note: The above is the basic formula under normal circumstances. In actual application, please make your choice in consideration of the safety of design article, fluctuation of power source, and actual starting acceleration, and loading.

馬達安裝須知 Instructions for Motor Installation

因馬達出力軸的不同，安裝亦有所不同。

Different installation methods result from different output shafts of motor.

◆ 圓軸型 Cylindrical shaft type

在安裝板上開孔後用螺絲、螺帽將馬達固定在安裝板上 (此產品不附螺絲、螺帽)。請注意馬達的安裝面與安裝板之間不要留有縫隙。

After drilling holes on the installation board, use nuts and screws to fasten the motor onto the installation board (screws and nuts are not offered with this motor). Please make sure there is no clearance between the motor's installation surface and installation board.

安裝用螺絲 Screws Used for Installation

型號 Model	螺絲尺寸 Screw Size	安裝力矩 Installation Torque
CM06、CG06	M4	20 kgfcm
CM07、CG07	M5	25 kgfcm
CM08、CG08	M5	25 kgfcm
CM09、CG09	M6	30 kgfcm

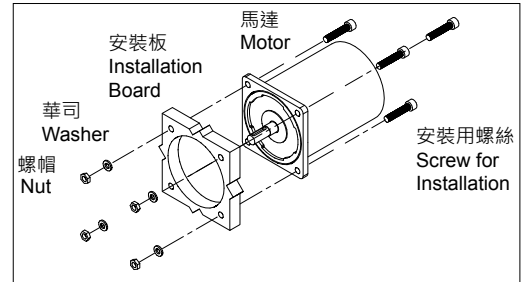

注意 Note :

請勿將馬達斜插入安裝孔或強行安裝、否則有可能會造成內緣部份受傷、馬達破損。

Please do not insert the motor obliquely into the installation hole or use force. It may cause damage to the interior or breakage of motor.

◆ 螺旋齒輪 (與減速機組合) Helical gear shaft (in combination with speed reducer)

在安裝板上開孔後，用另售的減速機所附屬的 4 根螺絲、螺帽將馬達和減速機固定在安裝板上。請注意安裝時不要使馬達的凸緣與減速機的內緣留有縫隙。請注意：馬達齒軸與減速機組合時應小心的左右旋轉減速機即可裝入，避免強行安裝導致齒輪碰傷，而造成齒輪受損減速機出現異常運轉聲，產品壽命將縮短亦可能造成事故。

After drilling holes on the installation plate, use the 4 screws and nuts supplied with the speed reducer, to fasten gear head and motor on the installation plate. Make sure there is no clearance between the flange of motor and the inside of speed reducer. (Caution: Please revolve the gearhead carefully to combine motor and gearhead. Please avoid using force for assembly. It will hurt gears. There will be noise at running. The life of gear motor will shorten or even cause an accident)

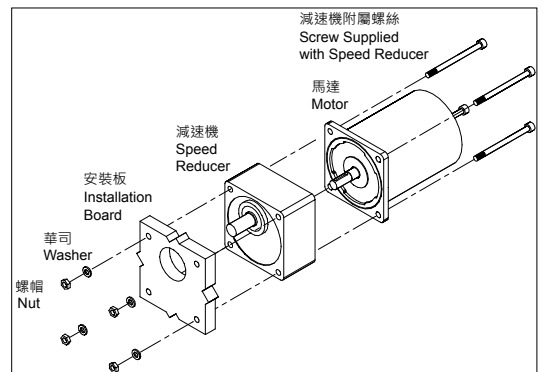

◆ 附散熱風扇的馬達附散熱風扇時，為了避免堵塞馬達後部的散熱孔，安裝時請在風扇外框後部空出 10mm 以上或開換氣孔。

Please leave the rear of motor unoccupied at least 10mm distance or open the breather while using the motor with fan.

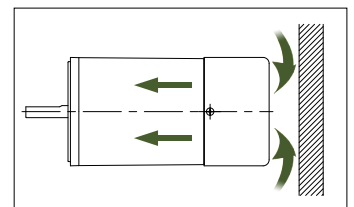

電容器安裝須知 Instructions for Capacitor Installation

※ 僅單相馬達有附 Only for Single Phase Motor

安裝前請先確認電容器規格是否與馬達銘牌上的規格相同。安裝電容器時，請使用 M4 螺絲 (此產品不附固定螺絲)。請注意：電容器固定時，螺絲的安裝力矩請控制在 10kgfcm 以下，以防止安裝腳損壞。電容器安裝地點應距離馬達 10cm 以上，以防止電容器因熱而縮短使用壽命。

Before installation, please make sure the capacitor specification is the same as that on the motor nameplate. To install the capacitor, please use M4 screws (Fixing screws are not offered).

Caution: Please adjust the install torque to mounting foot. The capacitor should be located at least 10cm faraway the motor, otherwise excessive head will shorten service life of capacitor.

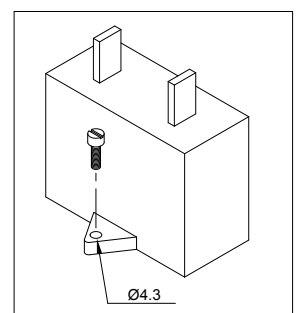

■ 附屬螺絲 Supplied Screws

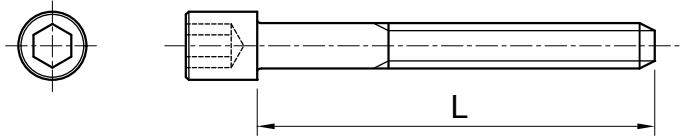

型號 Model	螺絲長度 Screw Length L(mm)	規格 Specification
CG06 □ 3~75S8	65	M4 P0.7
CG06 □ 90~300S8	70	M4 P0.7
CG07 □ 3~75S10	65	M5 P0.8
CG07 □ 90~240S10	70	M5 P0.8
CG08 □ 3~75S10	70	M5 P0.8
CG08 □ 90~300S10	80	M5 P0.8
CG09 □ 3~75S12	85	M6 P1.0
CG09 □ 90~240S12	95	M6 P1.0
CG09 □ 3~75S15	85	M6 P1.0
CG09 □ 90~240S15	95	M6 P1.0

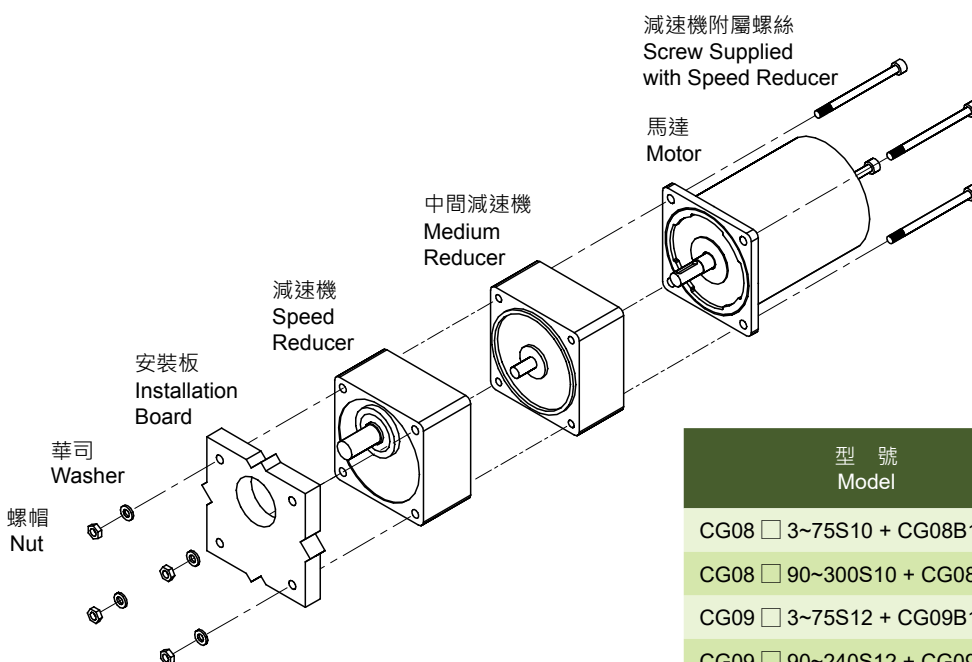
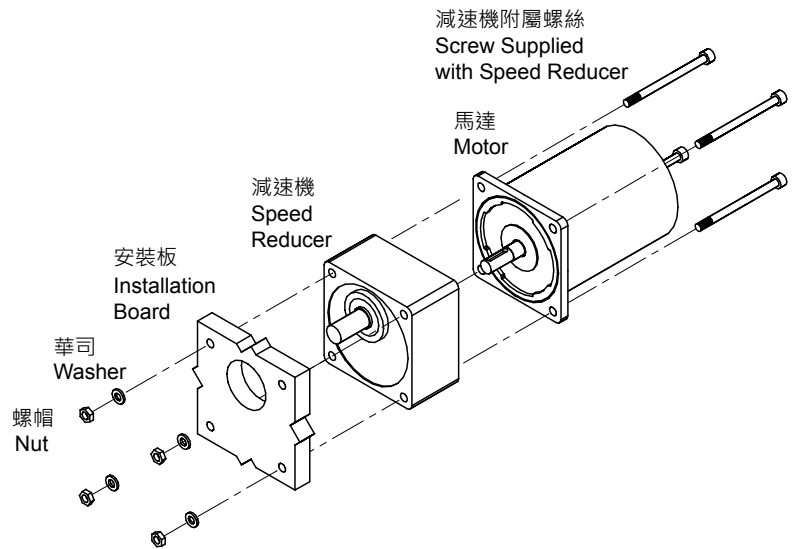

型號 Model	螺絲長度 Screw Length L(mm)	規格 Specification
CG08 □ 3~75S10 + CG08B10X	110	M5 P0.8
CG08 □ 90~300S10 + CG08B10X	120	M5 P0.8
CG09 □ 3~75S12 + CG09B10X	140	M6 P1.0
CG09 □ 90~240S12 + CG09B10X	150	M6 P1.0
CG09 □ 3~75S15 + CG09B10X	140	M6 P1.0
CG09 □ 90~240S15 + CG09B10X	150	M6 P1.0

單相感應式馬達 Single-Phase Induction Motor

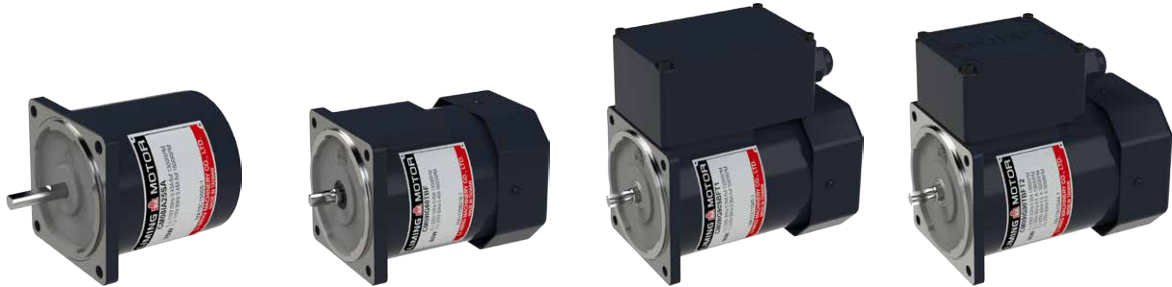

單相感應式馬達 Single-Phase Induction Motor

感應式馬達特徵：適用於單相馬達單方向連續連轉。

Characteristics of induction motor: Applicable to single-phase motor in single direction continuous operation.

馬達一般規格 Motor General Specification

絕緣阻抗：在馬達的線圈與外殼間以 DC500V 高阻計測定，其數值在 100MΩ 以上。

絕緣耐壓：在馬達的線圈與外殼間施加 50Hz 或 60Hz、1.5KV、1 分鐘無發生異常現象。

溫度上升：於馬達額定運轉後以電阻法測定，溫度上升值在 80°C 以下。

絕緣等級：B 種 (130°C)

保護等級：導線型 IP20，端子盒型 IP54。

使用溫度：-10°C ~+50°C (電容連續運轉馬達 -10°C ~+40°C) (不結凍狀態)。

使用濕度：85% 以下 (不結露狀態)。

Insulation impedance: Measure with DC500V high resistance gauge between the coil and casing of motor, the reading is 100M or higher.

Insulation resistance to pressure: Apply 50Hz or 60Hz, 1.5V between the coil and casing of motor for one minute without irregularity resulted.

Temperature rise: To specify by resistance method after motor reaches rated operation, temperature is less than 80°C.

Insulation: B (130°C)

Protection: Motor with conductive wire is IP20; motor with terminal box is IP54.

Operating temperature: -10°C ~+50°C (Capacitor operation motor -10°C ~+40°C) (No freezing)

Operating humidity: 85% or less (No condensation)

馬達接線圖 Motor Wiring Diagram

◆單相馬達 Single-Phase Motor

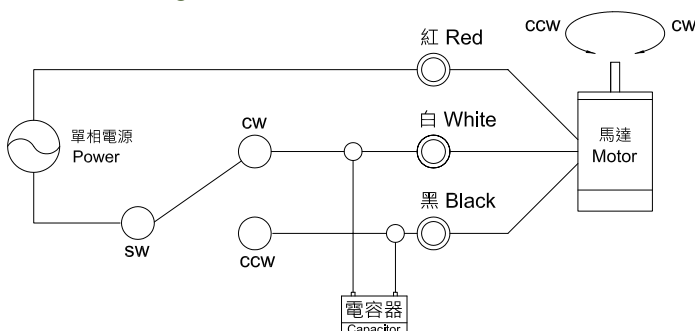

感應馬達機構 Induction Motor Machinery

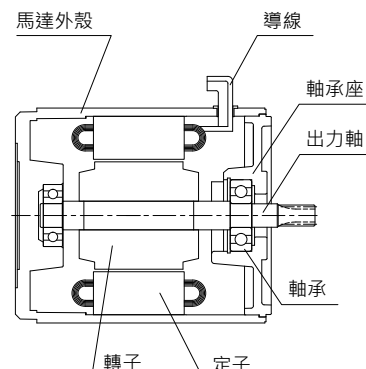

馬達線圖 Motor

CM06 □ 6

註：IA (*) 為 IA 型相關尺寸

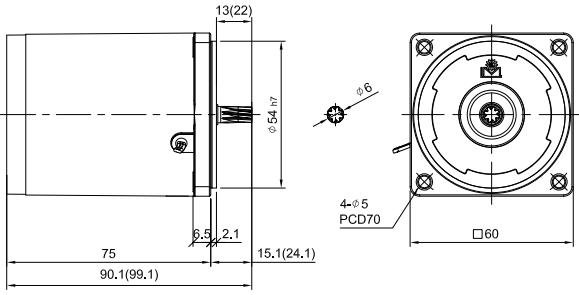

重量 Weight : 0.9kg ±5%

減速機線圖 Gear Head

CG06B □ S □

註：(*) 為 1/90~1/300 之尺寸

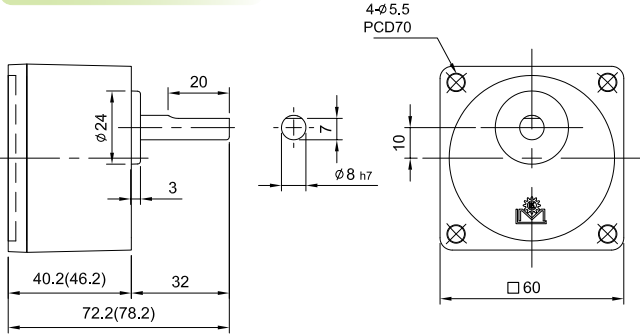

直接連結減速馬達時之容許轉矩 Permissible Torque of Direct Link Gearmotor

輸出功率 Output Power	馬達型號 Motor Model	減速機型號 Reducer Model	減速比 Ratio	轉速 Speed (RPM)		容許 Permissible (kgf-cm)		減速機出力軸旋轉方向 Rotating direction of output shaft of speed reducer
				50Hz	60Hz	50Hz	60Hz	
6W	CM06IG06	CG06 □	3	500	600	1.2	1.0	(A) 與馬達同一方向旋轉 Rotating in the same direction as the motor
			5	300	360	1.9	1.5	
			6	250	300	2.3	1.8	
			7.5	200	240	2.9	2.3	
			9	166	200	3.4	2.8	
			12.5	120	144	4.7	3.9	
			15	100	120	5.7	4.7	(B) 與馬達相反方向旋轉 Rotating in the opposite direction to the motor
			18	83	100	6.8	5.6	
			25	60	72	9.3	7.0	
			30	50	60	11	8.3	
			36	42	50	13	10	
			50	30	36	16	13.8	
			60	25	30	20	16	(C) 與馬達同一方向旋轉 Rotating in the same direction as the motor
			75	20	24	24	20	
			90	17	20	30	24	
			100	15	18	30	30	
			120	12.5	15	30	30	
			150	10	12	30	30	
180	8.3	10	30	30				
200	7.5	9	30	30				
240	6.25	7.5	30	30				
300	5	6	30	30				

6W 馬達規格表

框號尺寸 SIZE (mm)	極數 Poles (P)	輸出功率 Output (W)	規格 Type	電壓 Voltage (V)	頻率 Frequency (Hz)	負荷 Duty (min)	額定 Rated Load				電容器 Capacitor (μ f/V)	啟動電流 Starting Current (A)	啟動轉矩 Starting Torque (kgf-cm)
							輸入功率 Input (W)	電流 Current (A)	轉速 Speed (RPM/min)	轉矩 Torque (kgf-cm)			
60	4	6	CM06IG6SA CM06IA6SA	100	50	CONT.	20	0.2	1300	0.4	2.5 / 250	0.3	0.3
				100	60	CONT.	18	0.19	1600	0.37	2.5 / 250	0.29	0.33
				110	50	CONT.	24	0.24	1300	0.45	2.5 / 250	0.32	0.4
				110	60	CONT.	22	0.21	1600	0.35	2.5 / 250	0.32	0.4
				120	50	CONT.	30	0.27	1300	0.54	2.5 / 250	0.36	0.46
				120	60	CONT.	27	0.23	1600	0.34	2.5 / 250	0.35	0.48
			CM06IG6SB CM06IA6SB	200	50	CONT.	18	0.09	1300	0.38	0.8 / 450	0.12	0.6
				200	60	CONT.	22	0.1	1600	0.35	0.8 / 450	0.13	0.6
				220	50	CONT.	21	0.09	1330	0.44	0.8 / 450	0.13	0.69
				220	60	CONT.	26	0.1	1600	0.41	0.8 / 450	0.14	0.72
				230	50	CONT.	24	0.1	1300	0.53	0.8 / 450	0.14	0.76
				230	60	CONT.	28	0.12	1600	0.45	0.8 / 450	0.15	0.84
240	50	CONT.	24	0.1	1350	0.43	0.8 / 450	0.14	0.83				
240	60	CONT.	30	0.12	1650	0.3	0.8 / 450	0.15	0.85				

如馬達特性變更，恕不另行通知，以馬達銘牌為準。

In case of change of motor characteristics, no further notice shall be given. The information shown on the nameplate of motor is taken as standard.

馬達線圖 Motor

CM07 □ 15

註：IA (*) 為 IA 型相關尺寸

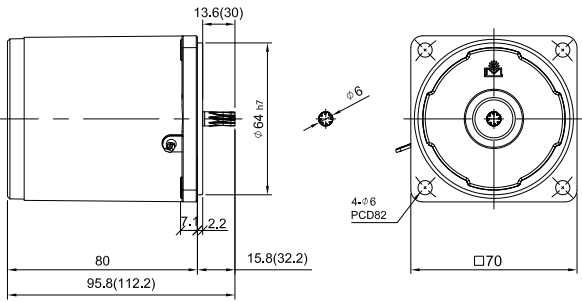

重量 Weight : 1.5kg ±5%

減速機線圖 Gear Head

CG07B □ S □

註：(*) 為 1/90~1/240 之尺寸

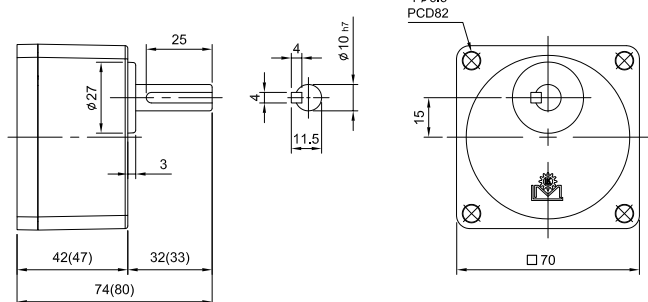

單相感應馬達

70 mm
15W

直接連結減速馬達時之容許轉矩 Permissible Torque of Direct Link Gearmotor

輸出功率 Output Power	馬達型號 Motor Model	減速機型號 Reducer Model	減速比 Ratio	轉速 Speed (RPM)		容許 Permissible (kgf-cm)		減速機出力軸旋轉方向 Rotating direction of output shaft of speed reducer
				50Hz	60Hz	50Hz	60Hz	
15W	CM07IG15	CG07 □	3	500	600	3.0	2.6	(A) 與馬達同一方向旋轉 Rotating in the same direction as the motor
			5	300	360	4.7	3.9	
			6	250	300	5.7	4.7	
			7.5	200	240	7.1	5.8	
			9	166	200	8.5	7.0	
			12.5	120	144	11.8	9.8	
			15	100	120	14.2	11.8	
			18	83	100	18	15	(B) 與馬達相反方向旋轉 Rotating in the opposite direction to the motor
			25	60	72	23	19	
			30	50	60	28	23	
			36	42	50	33	27.6	
			50	30	36	46	38.4	
			60	25	30	50	46	
			75	20	24	50	50	
			90	17	20	50	50	(C) 與馬達同一方向旋轉 Rotating in the same direction as the motor
			100	15	18	50	50	
			120	12.5	15	50	50	
150	10	12	50	50				
180	8.3	10	50	50				
200	7.5	9	50	50				
240	6.25	7.5	50	50				
	300	5	6	-	-			

15W 馬達規格表

框號尺寸 SIZE (mm)	極數 Poles (P)	輸出功率 Output (W)	規格 Type	電壓 Voltage (V)	頻率 Frequency (Hz)	負荷 Duty (min)	額定 Rated Load				電容器 Capacitor (µf/V)	啟動電流 Starting Current (A)	啟動轉矩 Starting Torque (kgf-cm)
							輸入功率 Input (W)	電流 Current (A)	轉速 Speed (RPM/min)	轉矩 Torque (kgf-cm)			
70	4	15	CM07IG15SA CM07IA15SA	100	50	CONT.	34	0.36	1300	1	6 / 250	0.6	1
				100	60	CONT.	36	0.35	1600	1	6 / 250	0.57	1
				110	50	CONT.	39	0.4	1300	1.1	5 / 250	0.66	0.96
				110	60	CONT.	37	0.35	1600	1	5 / 250	0.61	1
				120	50	CONT.	45	0.47	1300	1.1	5 / 250	0.71	1.1
				120	60	CONT.	37	0.43	1600	1	5 / 250	0.66	1
			CM07IG15SB CM07IA15SB	200	50	CONT.	40	0.22	1250	1.1	1.5 / 450	0.34	0.89
				200	60	CONT.	38	0.19	1560	0.97	1.5 / 450	0.32	0.89
				220	50	CONT.	24	0.25	1200	1.2	1 / 450	0.36	0.89
				220	60	CONT.	41	0.2	1550	0.95	1 / 450	0.33	0.87
				230	50	CONT.	51	0.26	1250	1.16	1 / 450	0.38	0.95
				230	60	CONT.	43	0.2	1600	0.9	1 / 450	0.35	0.95
				240	50	CONT.	55	0.27	1300	1.13	1 / 450	0.4	1
				240	60	CONT.	46	0.21	1600	1	1 / 450	0.37	1

如馬達特性變更，恕不另行通知，以馬達銘牌為準。
In case of change of motor characteristics, no further notice shall be given. The information shown on the nameplate of motor is taken as standard.

馬達線圖 Motor

CM08 □ 25

註：IA (*) 為 IA 型相關尺寸

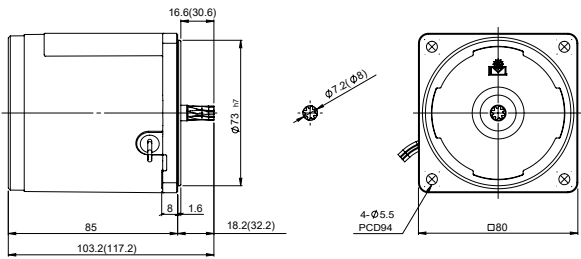

重量 Weight : 1.5kg ±5%

CM08 □ 25F

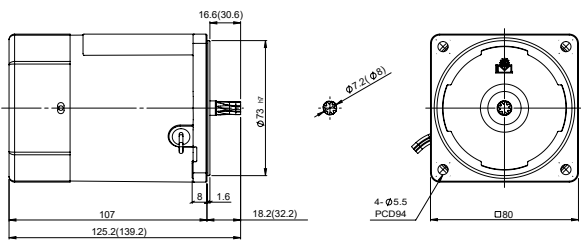

重量 Weight : 1.6kg ±5%

CM08 □ 25T

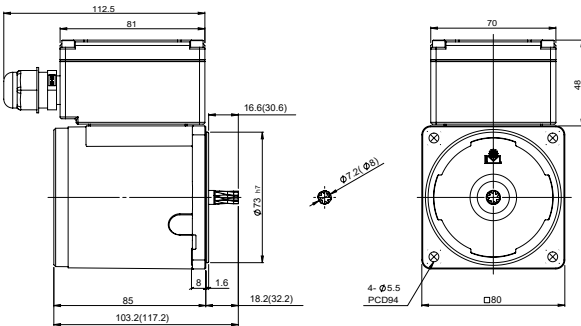

重量 Weight : 2kg ±5%

CM08 □ 25T1

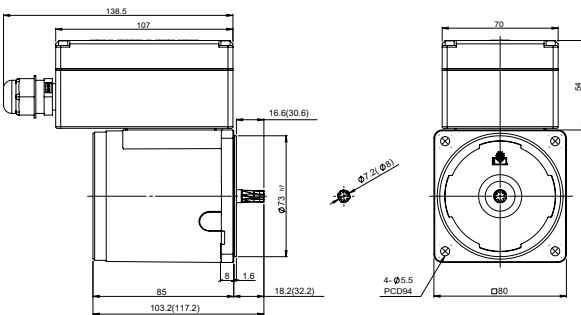

重量 Weight : 1.7kg ±5%

減速機線圖 Gear Head

CG08B □ S □

註：(*) 為 1/90~1/300 之尺寸

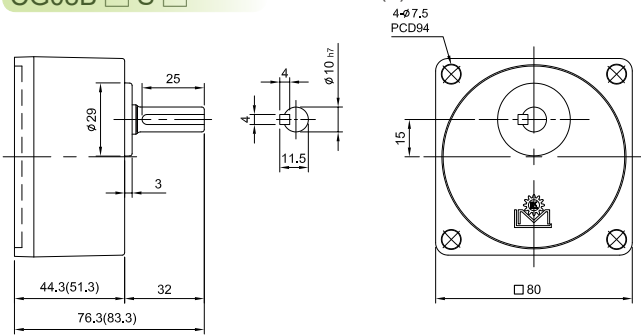

CG08B □ X

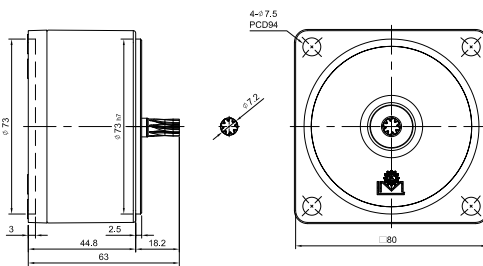

直接連結減速馬達時之容許轉矩 Permissible Torque of Direct Link Gearmotor

輸出功率 Output Power	馬達型號 Motor Model	減速機型號 Reducer Model	減速比 Ratio	轉速 Speed (RPM)		容許 Permissible (kgf·cm)		減速機出力軸旋轉方向 Rotating direction of output shaft of speed reducer
				50Hz	60Hz	50Hz	60Hz	
25W	CM08IG25	CG08 □	3	500	600	5.0	4.1	(A) 與馬達同一方向旋轉 Rotating in the same direction as the motor
			5	300	360	7.8	6.3	
			6	250	300	9.4	7.6	
			7.5	200	240	11.8	9.5	
			9	166	200	14.1	11.4	
			12.5	120	144	19.6	16	
			15	100	120	23	19	
			18	83	100	28	23	
			25	60	72	38	31	(B) 與馬達相反方向旋轉 Rotating in the opposite direction to the motor
			30	50	60	46	37	
			36	42	50	55	45	
			50	30	36	76	62	
			60	25	30	80	75	
			75	20	24	80	80	
			90	17	20	80	80	
			100	15	18	80	80	
			120	12.5	15	80	80	(C) 與馬達同一方向旋轉 Rotating in the same direction as the motor
			150	10	12	80	80	
			180	8.3	10	80	80	
			200	7.5	9	80	80	
240	6.25	7.5	80	80				
300	5	6	80	80				

25W 馬達規格表

框號尺寸 SIZE (mm)	極數 Poles (P)	輸出功率 Output (W)	規格 Type	電壓 Voltage (V)	頻率 Frequency (Hz)	負荷 Duty (min)	額定 Rated Load				電容器 Capacitor (μ f/V)	啟動電流 Starting Current (A)	啟動轉矩 Starting Torque (kgf·cm)
							輸入功率 Input (W)	電流 Current (A)	轉速 Speed (RPM/min)	轉矩 Torque (kgf·cm)			
80	4	25	CM08IG25SA CM08IA25SA	100	50	CONT.	46	0.5	1250	1.9	6 / 250	0.89	1.1
				100	60	CONT.	41	0.42	1550	1.5	6 / 250	0.84	1.1
				110	50	CONT.	49	0.5	1300	1.9	6 / 250	1	1.4
				110	60	CONT.	43	0.4	1640	1.4	6 / 250	0.9	1.5
				120	50	CONT.	55	0.5	1350	1.8	6 / 250	1	1.7
				120	60	CONT.	49	0.42	1650	1.4	6 / 250	1	1.6
			CM08IG25SB CM08IA25SB	220	50	CONT.	50	0.25	1300	1.8	1.5 / 450	0.48	1.4
				220	60	CONT.	45	0.21	1600	1.5	1.5 / 450	0.46	1.4
				230	50	CONT.	53	0.26	1300	1.9	1.5 / 450	0.46	1.5
				230	60	CONT.	47	0.21	1600	1.5	1.5 / 450	0.43	1.6
				240	50	CONT.	26	0.26	1300	1.8	1.5 / 450	0.48	1.6
				240	60	CONT.	49	0.21	1600	1.5	1.5 / 450	0.46	1.6

如馬達特性變更，恕不另行通知，以馬達銘牌為準。

In case of change of motor characteristics, no further notice shall be given. The information shown on the nameplate of motor is taken as standard.

馬達線圖 Motor

CM09 □ 40

註：IA (*) 為 IA 型相關尺寸

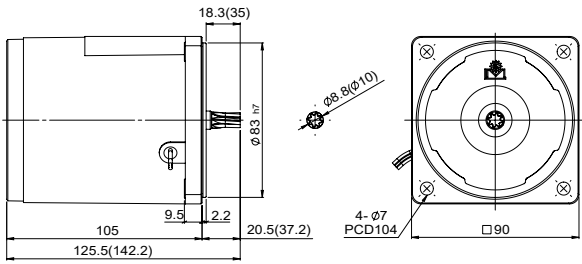

重量 Weight : 2.3kg ±5%

CM09 □ 40T

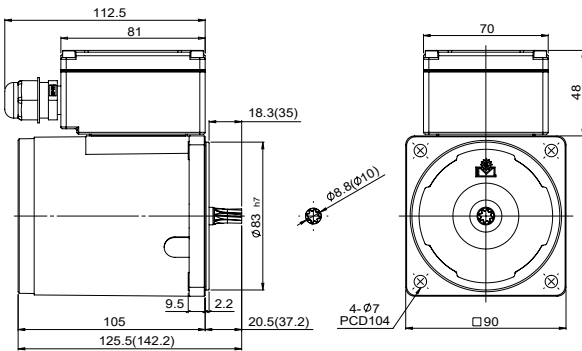

重量 Weight : 2.7kg ±5%

CM09 □ 40T1

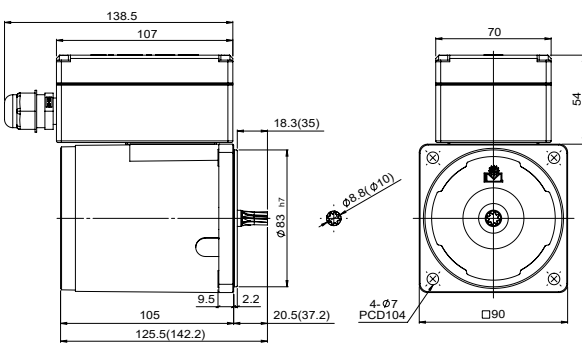

重量 Weight : 2.5kg ±5%

減速機線圖 Gear Head

CG09B □ S □

註：(*) 為 1/90~1/240 之尺寸

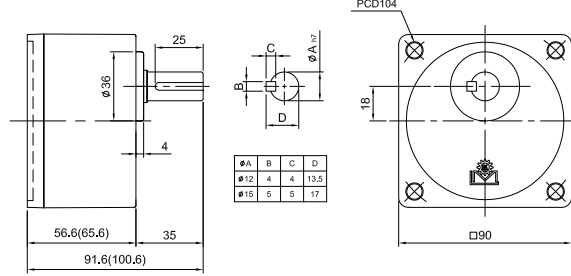

CG09B □ X

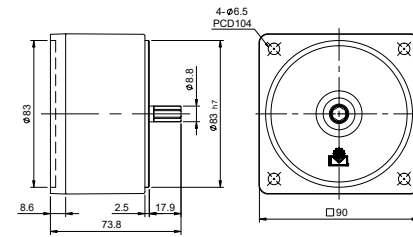

CGCU09B □ S □

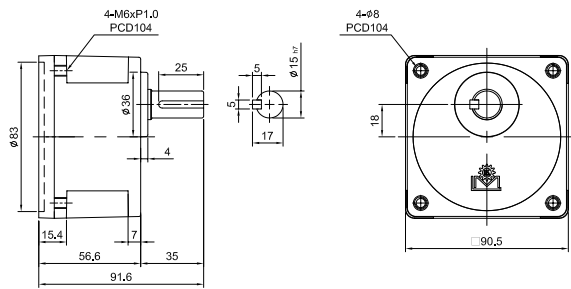

CGU09B □ S □

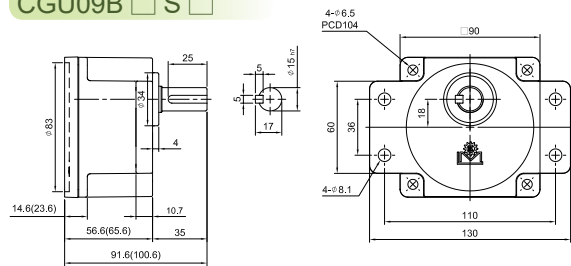

CGB09B □ H □

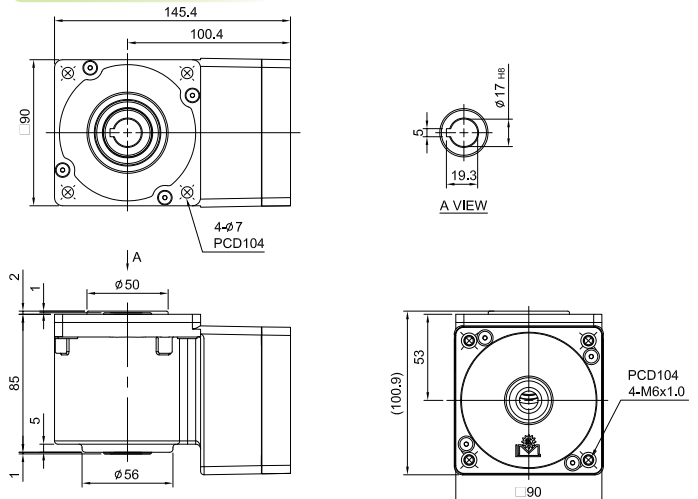

直接連結減速馬達時之容許轉矩 Permissible Torque of Direct Link Gearmotor

輸出功率 Output Power	馬達型號 Motor Model	減速機型號 Reducer Model	減速比 Ratio	轉速 Speed (RPM)		容許 Permissible (kgf·cm)		減速機出力軸旋轉方向 Rotating direction of output shaft of speed reducer
				50Hz	60Hz	50Hz	60Hz	
40W	CM09IG40	CG09 □	3	500	600	7.3	6.3	(A) 與馬達同一方向旋轉 Rotating in the same direction as the motor
			5	300	360	12	10	
			6	250	300	14.7	12	
			7.5	200	240	18	15	
			9	166	200	22	19	
			12.5	120	144	30	26	
			15	100	120	36	30	
			18	83	100	43	37	(B) 與馬達相反方向旋轉 Rotating in the opposite direction to the motor
			25	60	72	54	45	
			30	50	60	65	54	
			36	42	50	77	65	
			50	30	36	100	90	
			60	25	30	100	100	
			75	20	24	100	100	
			90	17	20	100	100	(C) 與馬達同一方向旋轉 Rotating in the same direction as the motor
			100	15	18	100	100	
			120	12.5	15	100	100	
			150	10	12	100	100	
180	8.3	10	100	100				
200	7.5	9	100	100				
240	6.25	7.5	100	100				

直接連結減速馬達時之容許轉矩 (中空軸) Permissible Torque of Direct Link Gearmotor (Hollow Output Shaft)

輸出功率 Output Power	馬達型號 Motor Model	減速機型號 Reducer Model	減速比 Ratio / 頻率 (Hz)	轉速 (RPM)														
				9	15	18	22.5	27	37.5	45	54	75	90	108	150	180		
40W	CM09IG40	CGB09 □	50Hz	轉速 RPM	166	100	83	66	55	40	33	27	20	16	13	10	8.3	
				容許 Nm	2.4	4.1	4.9	6.1	7.4	10.3	12.3	14.8	14.8	14.8	14.8	14.8	14.8	14.8
			60Hz	轉速 RPM	200	120	100	80	66	48	40	33	24	20	16	12	10	
				容許 Nm	2.3	3.8	4.6	5.8	6.9	9.7	11.6	13.9	13.9	13.9	13.9	13.9	13.9	13.9
減速機出力軸旋轉方向 Rotating direction of output shaft of speed reducer				(A) 與馬達相反方向旋轉 Rotating in the opposite direction to the motor							(B) 與馬達同一方向旋轉 Rotating in the same direction as the motor							

40W 馬達規格表

框號尺寸 SIZE (mm)	極數 Poles (P)	輸出功率 Output (W)	規格 Type	電壓 Voltage (V)	頻率 Frequency (Hz)	負荷 Duty (min)	額定 Rated Load				電容器 Capacitor (μf/V)	啟動電流 Starting Current (A)	啟動轉矩 Starting Torque (kgf·cm)
							輸入功率 Input (W)	電流 Current (A)	轉速 Speed (RPM/min)	轉矩 Torque (kgf·cm)			
90	4	40	CM09IG40SA CM09IA40SA	100	50	CONT.	77	0.83	1350	3.2	10 / 250	1.9	1.8
				100	60	CONT.	99	0.65	1650	2.3	10 / 250	1.7	1.8
				110	50	CONT.	87	0.88	1350	3.4	10 / 250	2	2.1
				110	60	CONT.	86	0.79	1650	3.2	10 / 250	1.84	2.3
			CM09IG40SB CM09IA40SB	200	50	CONT.	78	0.4	1300	3	3.5 / 450	0.57	2.9
				200	60	CONT.	99	0.52	1550	2.5	3.5 / 450	0.58	3.2
				220	50	CONT.	72	0.32	1300	3	2.5 / 450	0.58	2.6
				220	60	CONT.	78	0.37	1600	2.5	2.5 / 450	0.55	2.6
				230	50	CONT.	74	0.32	1300	3	2.5 / 450	0.6	2.6
				230	60	CONT.	82	0.38	1600	2.5	2.5 / 450	0.58	2.8
				240	50	CONT.	72	0.3	1350	2.9	2.5 / 450	0.63	2.8
				240	60	CONT.	83	0.37	1650	2.3	2.5 / 450	0.6	2.8

如馬達特性變更，恕不另行通知，以馬達銘牌為準。

In case of change of motor characteristics, no further notice shall be given. The information shown on the nameplate of motor is taken as standard.

馬達線圖 Motor

CM09 □ 60F

註：IA (*) 為 IA 型相關尺寸

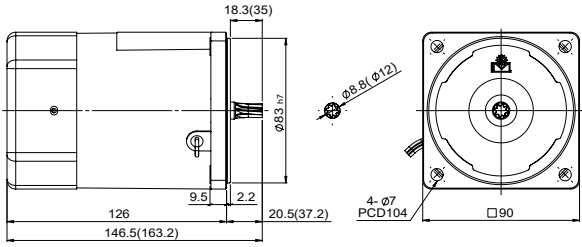

重量 Weight : 2.5kg ±5%

CM09 □ 60 □ FT

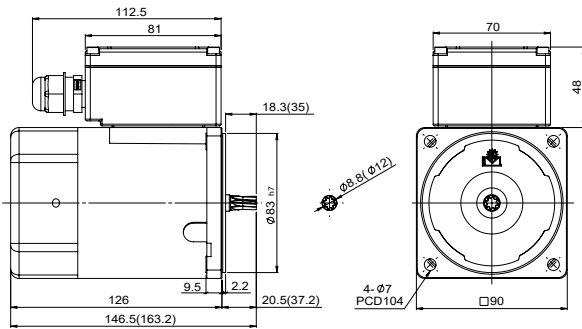

重量 Weight : 2.8kg ±5%

CM09 □ 60 □ FT1

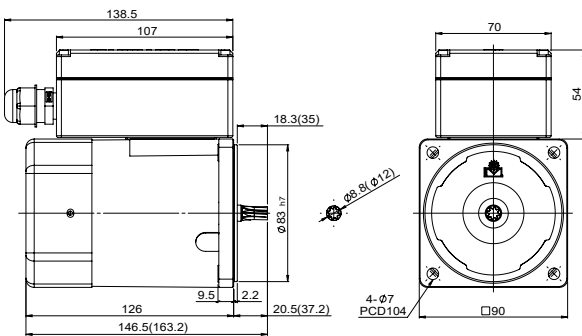

重量 Weight : 2.7kg ±5%

減速機線圖 Gear Head

CG09B □ S □

註：(*) 為 1/90~1/240 之尺寸

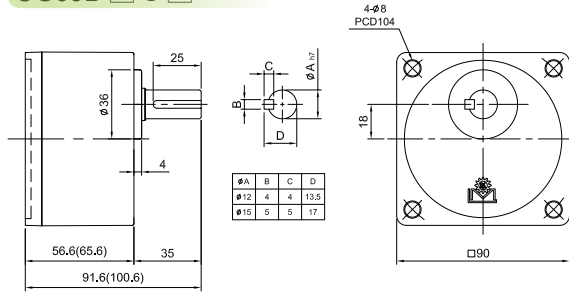

CG09B □ X

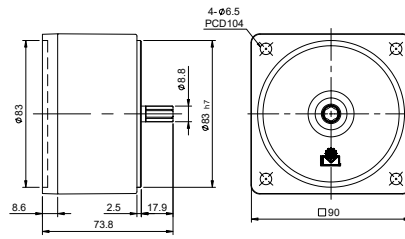

CGCU09B □ S □

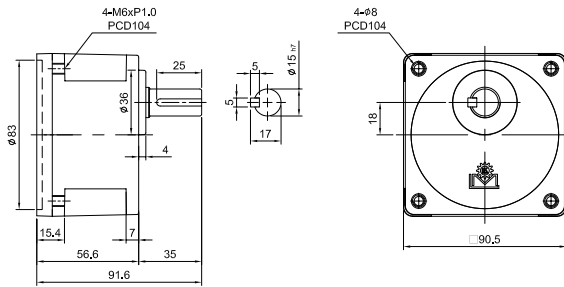

CGU09B □ S □

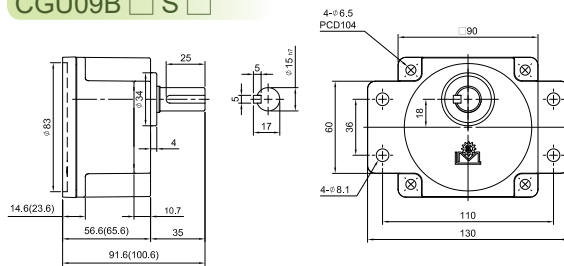

CGB09B □ H □

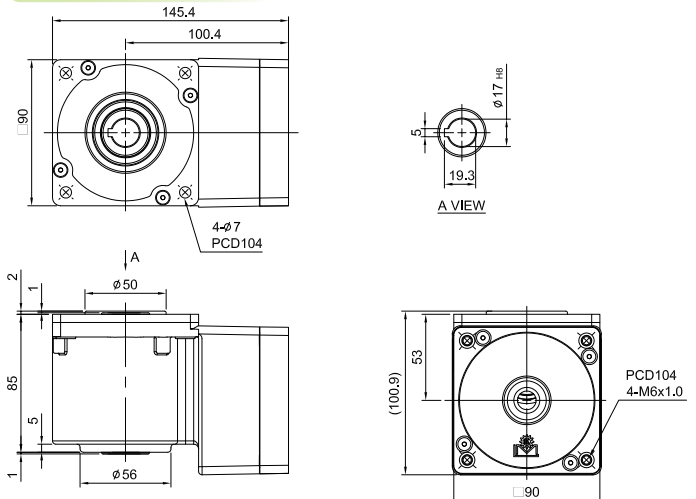

直接連結減速馬達時之容許轉矩 Permissible Torque of Direct Link Gearmotor

輸出功率 Output Power	馬達型號 Motor Model	減速機型號 Reducer Model	減速比 Ratio	轉速 Speed (RPM)		容許 Permissible (kgf·cm)		減速機出力軸旋轉方向 Rotating direction of output shaft of speed reducer
				50Hz	60Hz	50Hz	60Hz	
60W	CM09IG60	CG09 □	3	500	600	12	9.8	(A) 與馬達同一方向旋轉 Rotating in the same direction as the motor
			5	300	360	19	16	
			6	250	300	22	19	
			7.5	200	240	28	24	
			9	166	200	34	28	
			12.5	120	144	48	40	
			15	100	120	55	47	
			18	83	100	62	55	(B) 與馬達相反方向旋轉 Rotating in the opposite direction to the motor
			25	60	72	82	69	
			30	50	60	98	83	
			36	42	50	118	100	
			50	30	36	164	138	
			60	25	30	196	160	
			75	20	24	200	175	
			90	17	20	200	200	(C) 與馬達同一方向旋轉 Rotating in the same direction as the motor
			100	15	18	200	200	
			120	12.5	15	200	200	
			150	10	12	200	200	
180	8.3	10	200	200				
200	7.5	9	200	200				
240	6.25	7.5	200	200				

直接連結減速馬達時之容許轉矩 (中空軸) Permissible Torque of Direct Link Gearmotor (Hollow Output Shaft)

輸出功率 Output Power	馬達型號 Motor Model	減速機型號 Reducer Model	減速比 Ratio / 頻率 (Hz)	9	15	18	22.5	27	37.5	45	54	75	90	108	150	180	減速機出力軸旋轉方向 Rotating direction of output shaft of speed reducer		
				60W	CM09IG60	CGB09 □	50Hz	轉速 RPM	166	100	83	66	55	40	33	27		20	16
			50Hz	容許 Nm	2.4	4.1	4.9	6.1	7.4	10.3	12.3	14.8	14.8	14.8	14.8	14.8	14.8	(B) 與馬達同一方向旋轉 Rotating in the same direction as the motor	
			60Hz	轉速 RPM	200	120	100	80	66	48	40	33	24	20	16	12	10		(B) 與馬達同一方向旋轉 Rotating in the same direction as the motor
			60Hz	容許 Nm	2.3	3.8	4.6	5.8	6.9	9.7	11.6	13.9	13.9	13.9	13.9	13.9	13.9		

60W 馬達規格表

框號尺寸 SIZE (mm)	極數 Poles (P)	輸出功率 Output (W)	規格 Type	電壓 Voltage (V)	頻率 Frequency (Hz)	負荷 Duty (min)	額定 Rated Load				電容器 Capacitor (μf / V)	啟動電流 Starting Current (A)	啟動轉矩 Starting Torque (kgf·cm)			
							輸入功率 Input (W)	電流 Current (A)	轉速 Speed (RPM/min)	轉矩 Torque (kgf·cm)						
90	4	60	CM09IG60SAF CM09IA60SAF	100	50	CONT.	99	1	1250	4.3	16 / 250	1.4	3			
				100	60	CONT.	127	1.3	1600	4.5	16 / 250	1.5	3			
				110	50	CONT.	110	1	1300	4.6	16 / 250	1.6	3.5			
				110	60	CONT.	119	1.1	1600	3.7	16 / 250	1.6	3.6			
				120	50	CONT.	118	1	1350	4.4	16 / 250	1.8	4.2			
				120	60	CONT.	130	1.1	1650	3.5	16 / 250	1.8	4.4			
						CM09IG60SBF CM09IA60SBF	200	50	CONT.	99	0.5	1300	4.4	4 / 450	0.9	3
							200	60	CONT.	100	0.5	1600	3.6	4 / 450	0.9	3.3
							220	50	CONT.	110	0.5	1350	4.4	4 / 450	1	3.7
							220	60	CONT.	113	0.5	1650	3.7	4 / 450	1	3.7
							230	50	CONT.	118	0.5	1350	4.6	4 / 450	1	4
							230	60	CONT.	116	0.5	1650	3.6	4 / 450	1	4.2
							240	50	CONT.	125	0.5	1350	4.5	4 / 450	1	4.5
							240	60	CONT.	125	0.5	1350	4.5	4 / 450	1	4.7

如馬達特性變更，恕不另行通知，以馬達銘牌為準。

In case of change of motor characteristics, no further notice shall be given. The information shown on the nameplate of motor is taken as standard.

馬達線圖 Motor

CM09 □ 90F

註：IA (*) 為 IA 型相關尺寸

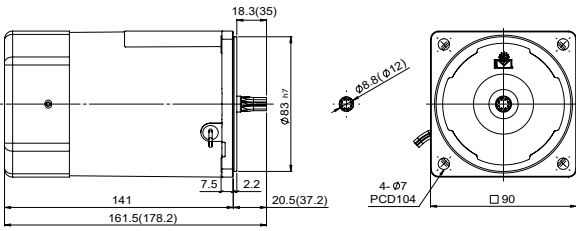

重量 Weight : 3.1kg ±5%

CM09 □ 90FT

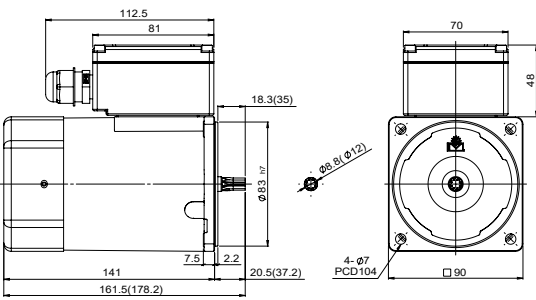

重量 Weight : 3.5kg ±5%

CM09 □ 90FT1

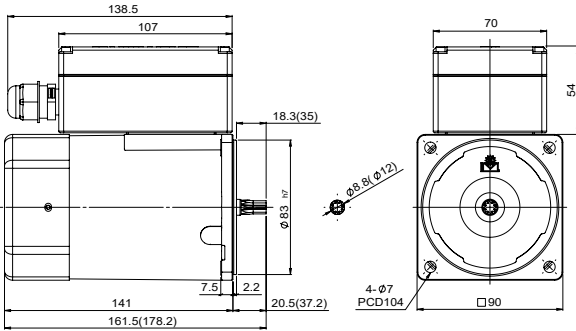

重量 Weight : 3.3kg ±5%

減速機線圖 Gear Head

CG09B □ S □

註：(*) 為 1/90~1/240 之尺寸

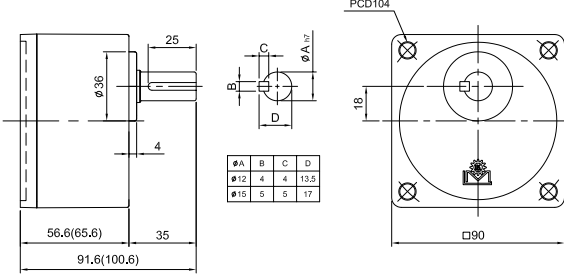

CG09B □ X

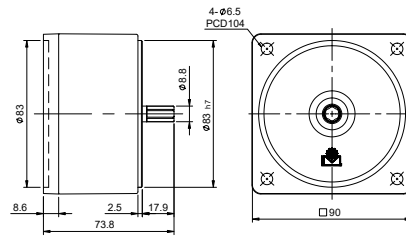

CGCU09B □ S □

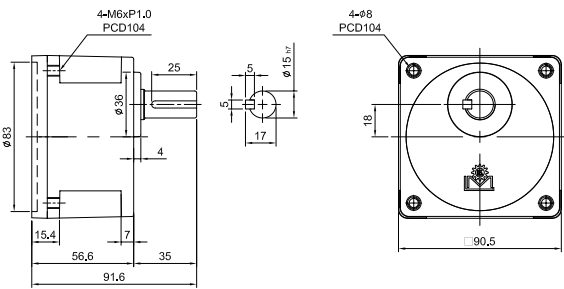

CGU09B □ S □

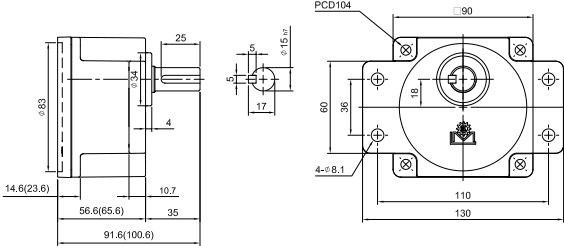

CGB09B □ H □

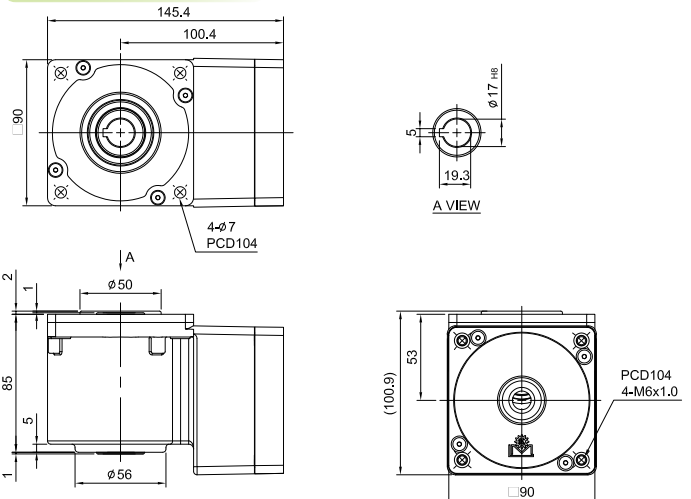

直接連結減速馬達時之容許轉矩 Permissible Torque of Direct Link Gearmotor

輸出功率 Output Power	馬達型號 Motor Model	減速機型號 Reducer Model	減速比 Ratio	轉速 Speed (RPM)		容許 Permissible (kgf·cm)		減速機出力軸旋轉方向 Rotating direction of output shaft of speed reducer
				50Hz	60Hz	50Hz	60Hz	
90W	CM09IG90	CG09 □	3	500	600	18	14	(A) 與馬達同一方向旋轉 Rotating in the same direction as the motor
			5	300	360	28	24	
			6	250	300	34	28	
			7.5	200	240	43	35	
			9	166	200	51	42	
			12.5	120	144	71	60	
			15	100	120	85	70	
			18	83	100	96	80	
			25	60	72	125	103	
			30	50	60	150	124	
			36	42	50	178	149	
			50	30	36	200	200	
			60	25	30	200	200	
			75	20	24	200	200	
			90	17	20	200	200	(C) 與馬達同一方向旋轉 Rotating in the same direction as the motor
			100	15	18	200	200	
			120	12.5	15	200	200	
			150	10	12	200	200	
180	8.3	10	200	200				
200	7.5	9	200	200				
			240	6.25	7.5	200	200	

直接連結減速馬達時之容許轉矩 (中空軸) Permissible Torque of Direct Link Gearmotor (Hollow Output Shaft)

輸出功率 Output Power	馬達型號 Motor Model	減速機型號 Reducer Model	減速比 Ratio / 頻率 (Hz)	轉速 RPM															
				9	15	18	22.5	27	37.5	45	54	75	90	108	150	180			
90W	CM09IG90	CGB09 □	50Hz	轉速 RPM	166	100	83	66	55	40	33	27	20	16	13	10	8.3		
				容許 Nm	2.4	4.1	4.9	6.1	7.4	10.3	12.3	14.8	14.8	14.8	14.8	14.8	14.8	14.8	
			60Hz	轉速 RPM	200	120	100	80	66	48	40	33	24	20	16	12	10		
				容許 Nm	2.3	3.8	4.6	5.8	6.9	9.7	11.6	13.9	13.9	13.9	13.9	13.9	13.9	13.9	
減速機出力軸旋轉方向 Rotating direction of output shaft of speed reducer				(A) 與馬達相反方向旋轉 Rotating in the opposite direction to the motor								(B) 與馬達同一方向旋轉 Rotating in the same direction as the motor							

90W 馬達規格表

框號尺寸 SIZE (mm)	極數 Poles (P)	輸出功率 Output (W)	規格 Type	電壓 Voltage (V)	頻率 Frequency (Hz)	負荷 Duty (min)	額定 Rated Load				電容器 Capacitor (μf/V)	啟動電流 Starting Current (A)	啟動轉矩 Starting Torque (kgf·cm)
							輸入功率 Input (W)	電流 Current (A)	轉速 Speed (RPM/min)	轉矩 Torque (kgf·cm)			
90	4	90	CM09IG90SAF CM09IA90SAF	100	50	CONT.	142	1.4	1250	6.7	20 / 250	2.4	3.7
				100	60	CONT.	142	1.4	1250	6.7	20 / 250	2.2	4
				110	50	CONT.	152	1.3	1300	6.8	20 / 250	2.6	4.5
				110	60	CONT.	148	1.4	1600	5.6	20 / 250	2.5	5
				120	50	CONT.	161	1.4	1350	6.4	20 / 250	3	5
				120	60	CONT.	163	1.3	1650	5.6	20 / 250	2.8	5.8
			CM09IG90SBF CM09IA90SBF	200	50	CONT.	135	0.7	1250	6.8	5 / 450	1.2	4.2
				200	60	CONT.	138	0.7	1550	5.6	5 / 450	1	4.2
				220	50	CONT.	147	0.68	1300	7.1	5 / 450	1.3	5.1
				220	60	CONT.	145	0.7	1600	5.4	5 / 450	1.2	5.1
				230	50	CONT.	144	0.6	1350	6.6	5 / 450	1.4	5.3
				230	60	CONT.	150	0.67	1650	5.3	5 / 450	1.3	5.6
				240	50	CONT.	150	0.6	1350	6.6	5 / 450	1.4	5.9
				240	60	CONT.	155	0.6	1650	5.3	5 / 450	1.4	6

如馬達特性變更，恕不另行通知，以馬達銘牌為準。

In case of change of motor characteristics, no further notice shall be given. The information shown on the nameplate of motor is taken as standard.

MEMO

三相感應式馬達 3-Phase Induction Motor

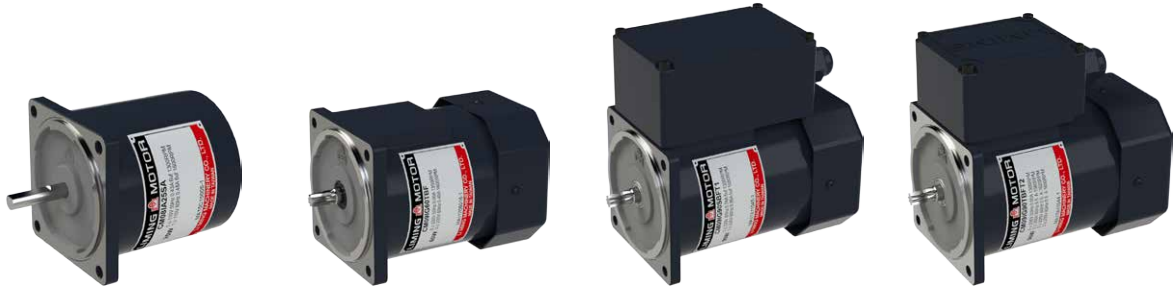

■ 三相感應式馬達 3-Phase Induction Motor

感應式馬達特徵：適用於單相馬達單方向連續連轉。

Characteristics of induction motor: Applicable to 3-phase motor in single direction continuous operation.

■ 馬達一般規格 Motor General Specification

絕緣阻抗：在馬達的線圈與外殼間以 DC500V 高阻計測定，其數值在 100MΩ 以上。

絕緣耐壓：在馬達的線圈與外殼間施加 50Hz 或 60Hz、1.5KV、1 分鐘無發生異常現象。

溫度上升：於馬達額定運轉後以電阻法測定，溫度上升值在 80°C 以下。

絕緣等級：B 種 (130°C)

保護等級：導線型 IP20，端子盒型 IP54。

使用溫度：-10°C ~+50°C (電容連續運轉馬達 -10°C ~+40°C) (不結凍狀態)。

使用濕度：85% 以下 (不結露狀態)。

Insulation impedance: Measure with DC500V high resistance gauge between the coil and casing of motor, the reading is 100M or higher.

Insulation resistance to pressure: Apply 50Hz or 60Hz, 1.5V between the coil and casing of motor for one minute without irregularity resulted.

Temperature rise: To specify by resistance method after motor reaches rated operation, temperature is less than 80°C.

Insulation: B (130°C)

Protection: Motor with conductive wire is IP20; motor with terminal box is IP54.

Operating temperature: -10°C ~+50°C (Capacitor operation motor -10°C ~+40°C) (No freezing)

Operating humidity: 85% or less (No condensation)

■ 馬達接線圖 Motor Wiring Diagram

◆ 三相馬達 3-Phase Motor

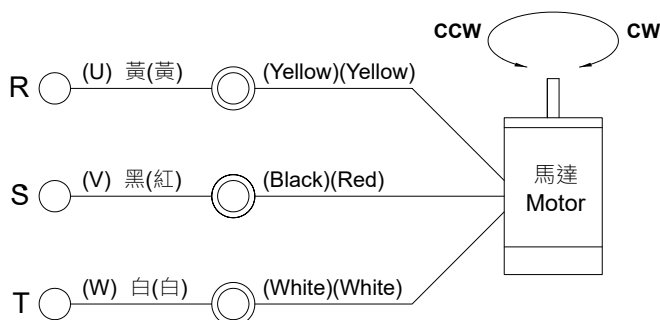

■ 感應馬達機構 Induction Motor Machinery

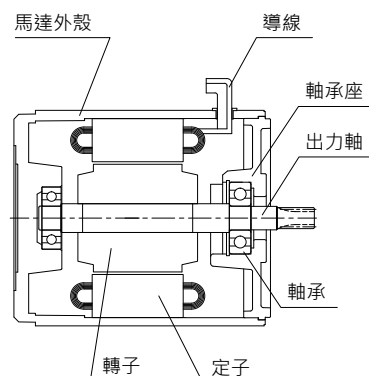

馬達線圖 Motor

CM08 □ 25

註：IA (*) 為 IA 型相關尺寸

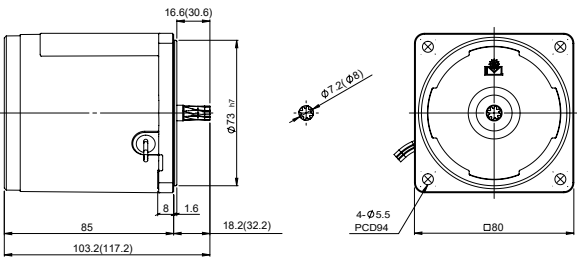

重量 Weight : 1.5kg ±5%

CM08 □ 25F

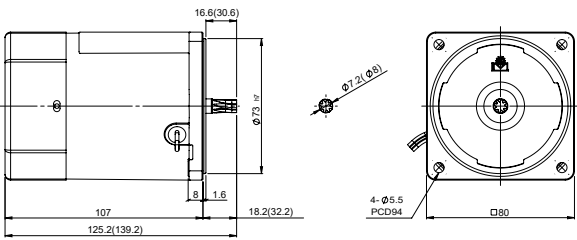

重量 Weight : 1.6kg ±5%

CM08 □ 25T

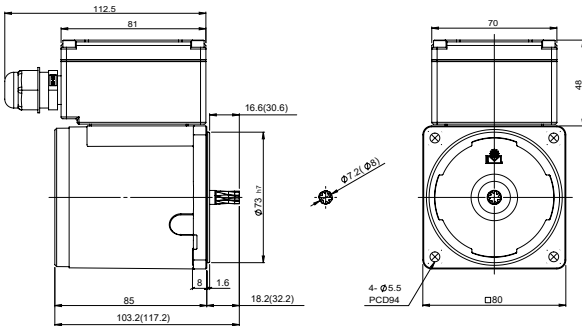

重量 Weight : 2kg ±5%

CM08 □ 25T1

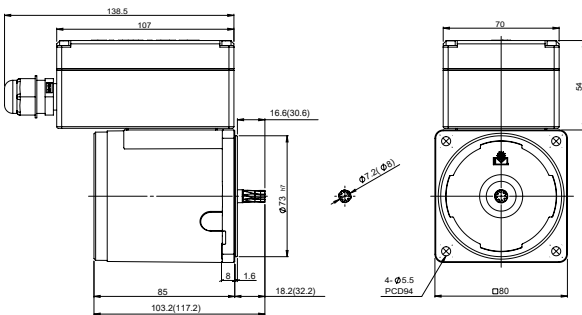

重量 Weight : 1.7kg ±5%

減速機線圖 Gear Head

CG08B □ S □

註：(*) 為 1/90~1/300 之尺寸

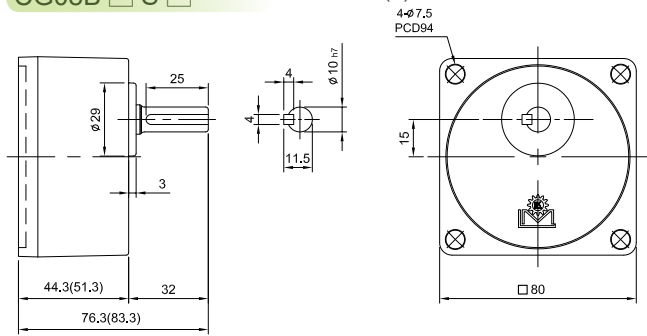

CG08B □ X

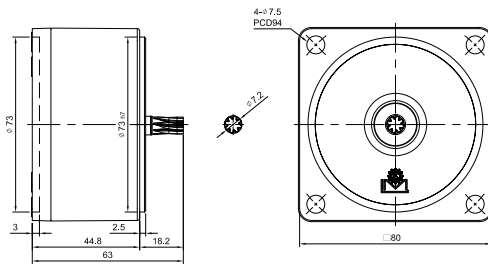

直接連結減速馬達時之容許轉矩 Permissible Torque of Direct Link Gearmotor

輸出功率 Output Power	馬達型號 Motor Model	減速機型號 Reducer Model	減速比 Ratio	轉速 Speed (RPM)		容許 Permissible (kgf·cm)		減速機出力軸旋轉方向 Rotating direction of output shaft of speed reducer
				50Hz	60Hz	50Hz	60Hz	
25W	CM08IG25	CG08 □	3	500	600	5.0	4.1	(A) 與馬達同一方向旋轉 Rotating in the same direction as the motor
			5	300	360	7.8	6.3	
			6	250	300	9.4	7.6	
			7.5	200	240	11.8	9.5	
			9	166	200	14.1	11.4	
			12.5	120	144	19.6	16	
			15	100	120	23	19	(B) 與馬達相反方向旋轉 Rotating in the opposite direction to the motor
			18	83	100	28	23	
			25	60	72	38	31	
			30	50	60	46	37	
			36	42	50	55	45	
			50	30	36	76	62	
			60	25	30	80	75	(C) 與馬達同一方向旋轉 Rotating in the same direction as the motor
			75	20	24	80	80	
			90	17	20	80	80	
			100	15	18	80	80	
			120	12.5	15	80	80	
			150	10	12	80	80	
180	8.3	10	80	80				
200	7.5	9	80	80				
240	6.25	7.5	80	80				
			300	5	6	80	80	

25W 馬達規格表

框號尺寸 SIZE (mm)	極數 Poles (P)	輸出功率 Output (W)	規格 Type	電壓 Voltage (V)	頻率 Frequency (Hz)	負荷 Duty (min)	額定 Rated Load				啟動電流 Starting Current (A)	啟動轉矩 Starting Torque (kgf·cm)
							輸入功率 Input (W)	電流 Current (A)	轉速 Speed (RPM/min)	轉矩 Torque (kgf·cm)		
80	4	25	CM08IG25TB CM08IA25TB	200	50	CONT.	44	0.21	1250	1.9	0.4	4.8
				200	60	CONT.	41	0.18	1500	1.6	0.4	3.6
				220	50	CONT.	49	0.23	1300	1.9	0.49	5.8
				220	60	CONT.	41	0.19	1550	1.5	0.46	4.6
				230	50	CONT.	50	0.24	1300	1.9	0.51	6.3
				230	60	CONT.	43	0.2	1600	1.5	0.48	4.9
			CM08IG25TC CM08IA25TC	380	50	CONT.	47	0.13	1300	1.8	0.27	5.6
				380	60	CONT.	42	0.11	1550	1.5	0.26	4.3
			CM08IG25TJ CM08IA25TJ	200	50	CONT.	45	0.21	1250	1.9	0.42	4.5
				200	60	CONT.	41	0.18	1500	1.5	0.4	3.5
				220	50	CONT.	48	0.23	1250	1.9	0.47	5.5
				220	60	CONT.	43	0.19	1550	1.5	0.44	4.3
				230	50	CONT.	48	0.23	1300	1.9	0.47	5.5
				230	60	CONT.	42	0.19	1550	1.5	0.44	4.3
380	50	CONT.	47	0.13	1300	1.8	0.27	5.5				
380	60	CONT.	41	0.11	1550	1.5	0.26	4.3				

如馬達特性變更，恕不另行通知，以馬達銘牌為準。

In case of change of motor characteristics, no further notice shall be given. The information shown on the nameplate of motor is taken as standard.

馬達線圖 Motor

CM09 □ 40

註：IA (*) 為 IA 型相關尺寸

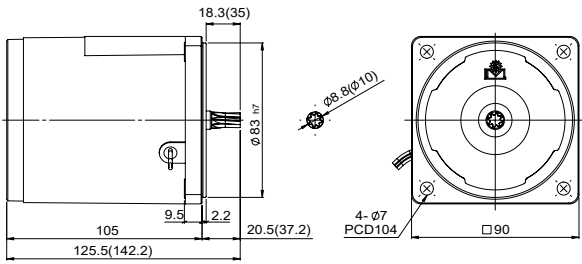

重量 Weight : 2.3kg ±5%

CM09 □ 40T

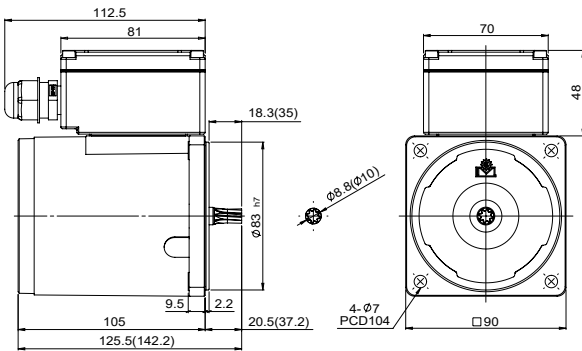

重量 Weight : 2.7kg ±5%

CM09 □ 40T1

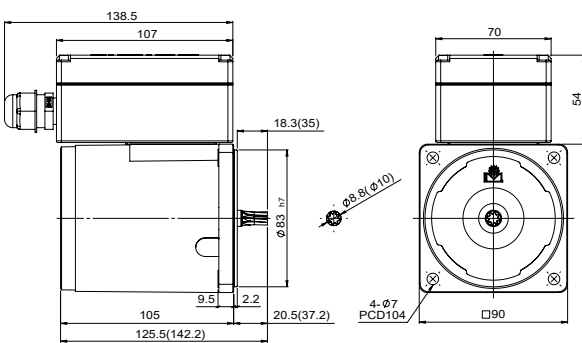

重量 Weight : 2.5kg ±5%

減速機線圖 Gear Head

CG09B □ S □

註：(*) 為 1/90~1/240 之尺寸

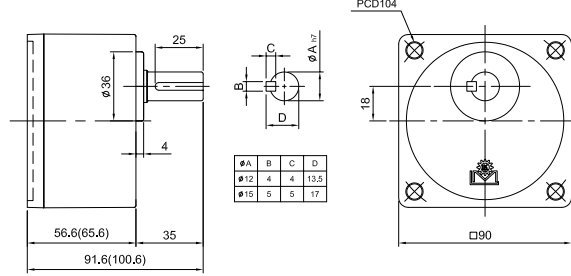

CG09B □ X

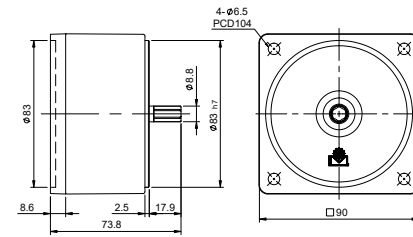

CGCU09B □ S □

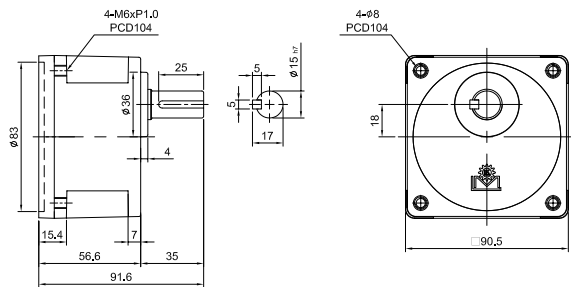

CGU09B □ S □

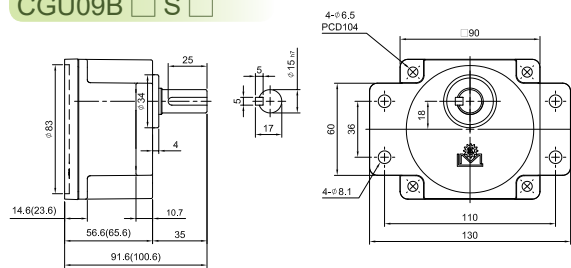

CGB09B □ H □

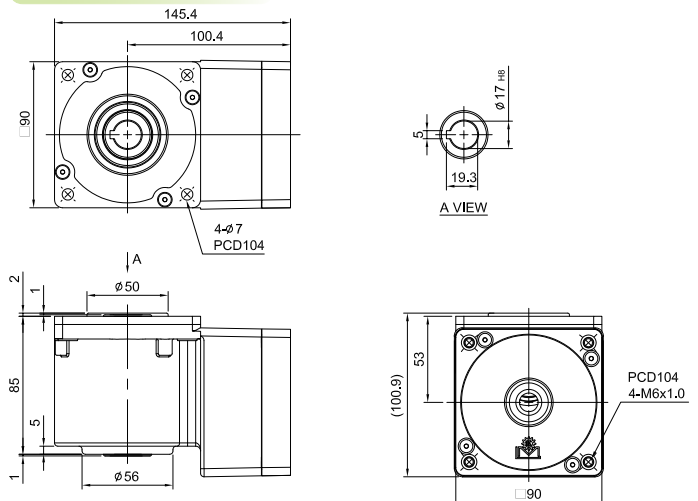

直接連結減速馬達時之容許轉矩 Permissible Torque of Direct Link Gearmotor

輸出功率 Output Power	馬達型號 Motor Model	減速機型號 Reducer Model	減速比 Ratio	轉速 Speed (RPM)		容許 Permissible (kgf·cm)		減速機出力軸旋轉方向 Rotating direction of output shaft of speed reducer
				50Hz	60Hz	50Hz	60Hz	
40W	CM09IG40	CG09 □	3	500	600	7.3	6.3	(A) 與馬達同一方向旋轉 Rotating in the same direction as the motor
			5	300	360	12	10	
			6	250	300	14.7	12	
			7.5	200	240	18	15	
			9	166	200	22	19	
			12.5	120	144	30	26	
			15	100	120	36	30	(B) 與馬達相反方向旋轉 Rotating in the opposite direction to the motor
			18	83	100	43	37	
			25	60	72	54	45	
			30	50	60	65	54	
			36	42	50	77	65	
			50	30	36	100	90	
			60	25	30	100	100	(C) 與馬達同一方向旋轉 Rotating in the same direction as the motor
			75	20	24	100	100	
			90	17	20	100	100	
			100	15	18	100	100	
			120	12.5	15	100	100	
			150	10	12	100	100	
180	8.3	10	100	100				
200	7.5	9	100	100				
240	6.25	7.5	100	100				

直接連結減速馬達時之容許轉矩 (中空軸) Permissible Torque of Direct Link Gearmotor (Hollow Output Shaft)

輸出功率 Output Power	馬達型號 Motor Model	減速機型號 Reducer Model	減速比 Ratio / 頻率 (Hz)	轉速 RPM															
				9	15	18	22.5	27	37.5	45	54	75	90	108	150	180			
40W	CM09IG40	CGB09 □	50Hz	轉速 RPM	166	100	83	66	55	40	33	27	20	16	13	10	8.3		
				容許 Nm	2.4	4.1	4.9	6.1	7.4	10.3	12.3	14.8	14.8	14.8	14.8	14.8	14.8	14.8	
			60Hz	轉速 RPM	200	120	100	80	66	48	40	33	24	20	16	12	10		
				容許 Nm	2.3	3.8	4.6	5.8	6.9	9.7	11.6	13.9	13.9	13.9	13.9	13.9	13.9	13.9	
減速機出力軸旋轉方向 Rotating direction of output shaft of speed reducer				(A) 與馬達相反方向旋轉 Rotating in the opposite direction to the motor								(B) 與馬達同一方向旋轉 Rotating in the same direction as the motor							

40W 馬達規格表

框號尺寸 SIZE (mm)	極數 Poles (P)	輸出功率 Output (W)	規格 Type	電壓 Voltage (V)	頻率 Frequency (Hz)	負荷 Duty (min)	額定 Rated Load				啟動電流 Starting Current (A)	啟動轉矩 Starting Torque (kgf·cm)
							輸入功率 Input (W)	電流 Current (A)	轉速 Speed (RPM/min)	轉矩 Torque (kgf·cm)		
90	4	40	CM09IG40TB CM09IA40TB	200	50	CONT.	72.8	0.29	1300	3.17	0.78	7.3
				200	60	CONT.	64	0.25	1600	2.42	0.73	5.5
				220	50	CONT.	69	0.29	1300	2.92	0.86	8.9
				220	60	CONT.	58	0.26	1600	2.52	0.8	6.8
				230	50	CONT.	73	0.3	1350	3	0.9	9.8
				230	60	CONT.	65	0.25	1650	2.4	0.83	7.5
			CM09IG40TC CM09IA40TC	380	50	CONT.	66	0.16	1350	2.8	0.48	9.1
				380	60	CONT.	64	0.14	1600	2.5	0.44	6.7
			CM09IG40TJ CM09IA40TJ	200	50	CONT.	62	0.26	1300	3	0.76	7.7
				200	60	CONT.	58	0.23	1600	2.4	0.7	5.8
				220	50	CONT.	62	0.27	1350	2.9	0.83	9.1
				220	60	CONT.	59	0.23	1600	2.4	0.77	6.9
				230	50	CONT.	62	0.28	1350	2.8	0.87	10
				230	60	CONT.	60	0.24	1650	2.4	0.81	7.5
380	50	CONT.	62	0.15	1350	2.9	0.47	9.2				
380	60	CONT.	61	0.13	1600	2.5	0.44	6.8				

如馬達特性變更，恕不另行通知，以馬達銘牌為準。

In case of change of motor characteristics, no further notice shall be given. The information shown on the nameplate of motor is taken as standard.

馬達線圖 Motor

CM09 □ 60F

註：IA (*) 為 IA 型相關尺寸

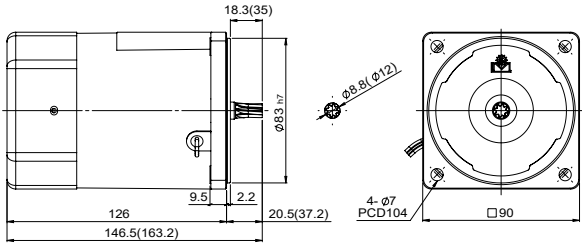

重量 Weight : 2.5kg ±5%

CM09 □ 60 □ FT

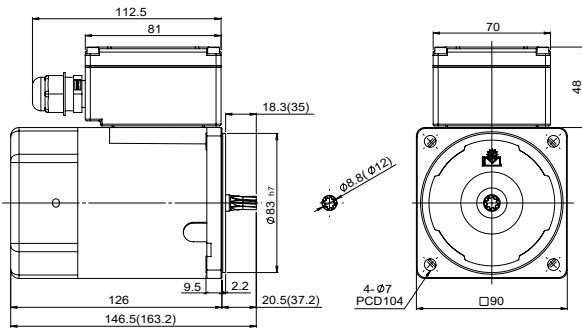

重量 Weight : 2.8kg ±5%

CM09 □ 60 □ FT1

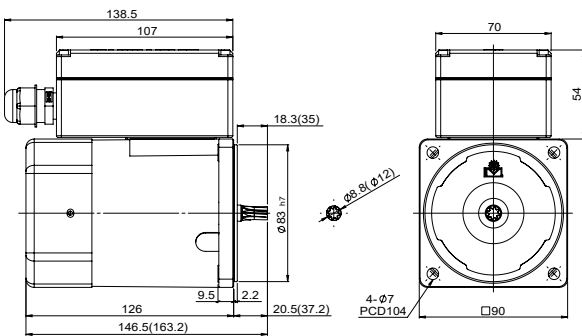

重量 Weight : 2.7kg ±5%

減速機線圖 Gear Head

CG09B □ S □

註：(*) 為 1/90~1/240 之尺寸

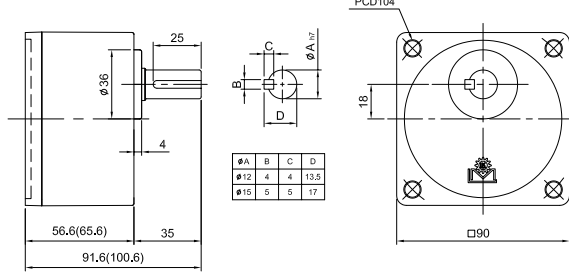

CG09B □ X

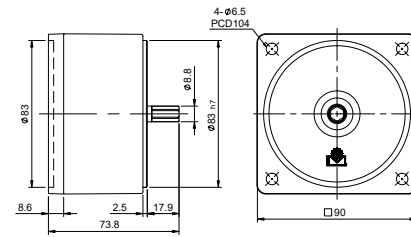

CGCU09B □ S □

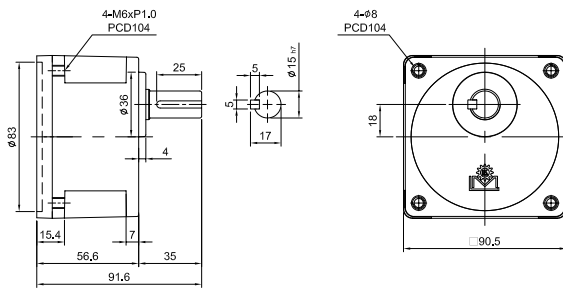

CGU09B □ S □

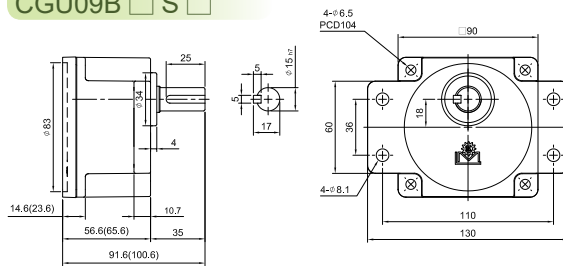

CGB09B □ H □

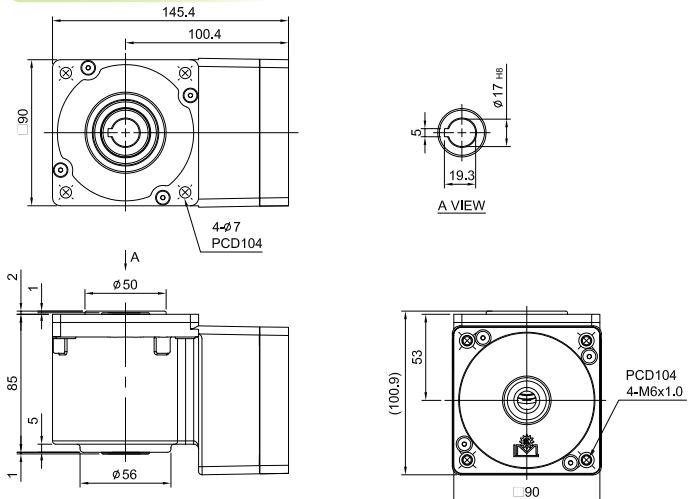

直接連結減速馬達時之容許轉矩 Permissible Torque of Direct Link Gearmotor

輸出功率 Output Power	馬達型號 Motor Model	減速機型號 Reducer Model	減速比 Ratio	轉速 Speed (RPM)		容許 Permissible (kgf-cm)		減速機出力軸旋轉方向 Rotating direction of output shaft of speed reducer
				50Hz	60Hz	50Hz	60Hz	
60W	CM09IG60	CG09 □	3	500	600	12	9.8	(A) 與馬達同一方向旋轉 Rotating in the same direction as the motor
			5	300	360	19	16	
			6	250	300	22	19	
			7.5	200	240	28	24	
			9	166	200	34	28	
			12.5	120	144	48	40	
			15	100	120	55	47	(B) 與馬達相反方向旋轉 Rotating in the opposite direction to the motor
			18	83	100	62	55	
			25	60	72	82	69	
			30	50	60	98	83	
			36	42	50	118	100	
			50	30	36	164	138	
			60	25	30	196	160	(C) 與馬達同一方向旋轉 Rotating in the same direction as the motor
			75	20	24	200	175	
			90	17	20	200	200	
			100	15	18	200	200	
			120	12.5	15	200	200	
			150	10	12	200	200	
180	8.3	10	200	200				
200	7.5	9	200	200				
240	6.25	7.5	200	200				

直接連結減速馬達時之容許轉矩 (中空軸) Permissible Torque of Direct Link Gearmotor (Hollow Output Shaft)

輸出功率 Output Power	馬達型號 Motor Model	減速機型號 Reducer Model	減速比 Ratio / 頻率 (Hz)	轉速 Speed (RPM)															
				9	15	18	22.5	27	37.5	45	54	75	90	108	150	180			
60W	CM09IG60	CGB09 □	50Hz	轉速 RPM	166	100	83	66	55	40	33	27	20	16	13	10	8.3		
				容許 Nm	3.3	5.5	6.7	8.3	10	13.9	16.7	20	20	20	20	20	20	20	
			60Hz	轉速 RPM	200	120	100	80	66	48	40	33	24	20	16	12	10		
				容許 Nm	2.6	4.4	5.3	6.7	8	11.2	13.4	16.1	16.1	16.1	16.1	16.1	16.1	16.1	
減速機出力軸旋轉方向 Rotating direction of output shaft of speed reducer				(A) 與馬達相反方向旋轉 Rotating in the opposite direction to the motor								(B) 與馬達同一方向旋轉 Rotating in the same direction as the motor							

60W 馬達規格表

框號尺寸 SIZE (mm)	極數 Poles (P)	輸出功率 Output (W)	規格 Type	電壓 Voltage (V)	頻率 Frequency (Hz)	負荷 Duty (min)	額定 Rated Load				啟動電流 Starting Current (A)	啟動轉矩 Starting Torque (kgf-cm)	
							輸入功率 Input (W)	電流 Current (A)	轉速 Speed (RPM/min)	轉矩 Torque (kgf-cm)			
90	4	60	CM09IG60TBF CM09IA60TBF	200	50	CONT.	94	0.4	1300	4.3	1	10.5	
				200	60	CONT.	92	0.36	1550	3.8	0.9	8	
				220	50	CONT.	99	0.43	1300	4.4	1.1	13	
				220	60	CONT.	91	0.36	1600	3.6	1.1	10	
				230	50	CONT.	100	0.46	1350	4.3	1.2	14.6	
			CM09IG60TCF CM09IA60TCF	230	60	CONT.	87	0.36	1650	3.5	1.1	11	
				380	50	CONT.	96	0.24	1350	4.3	0.69	13	
				380	60	CONT.	89	0.2	1600	3.6	0.65	10	
				CM09IG60TJF CM09IA60TJF	200	50	CONT.	96	0.4	1300	4.4	1	10.4
					200	60	CONT.	93	0.36	1550	3.7	1	8
					220	50	CONT.	100	0.43	1300	4.3	1.1	12.6
					220	60	CONT.	93	0.36	1600	3.6	1.1	9.7
					230	50	CONT.	104	0.46	1350	4.3	1.2	13.6
				230	60	CONT.	93	0.37	1600	3.6	1.1	10.5	
380	50	CONT.	102	0.25	1300	4.4	0.66	12.2					
380	60	CONT.	93	0.21	1600	3.6	0.62	9.4					

如馬達特性變更，恕不另行通知，以馬達銘牌為準。

In case of change of motor characteristics, no further notice shall be given. The information shown on the nameplate of motor is taken as standard.

馬達線圖 Motor

CM09 □ 90F

註：IA (*) 為 IA 型相關尺寸

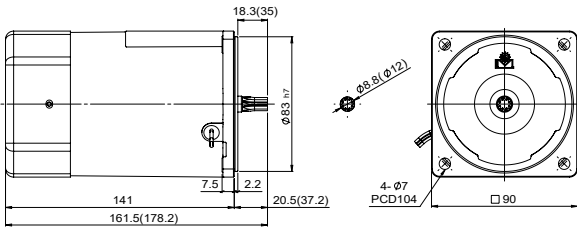

重量 Weight : 3.1kg ±5%

CM09 □ 90FT

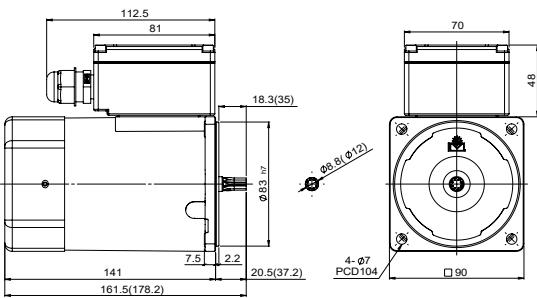

重量 Weight : 3.5kg ±5%

CM09 □ 90FT1

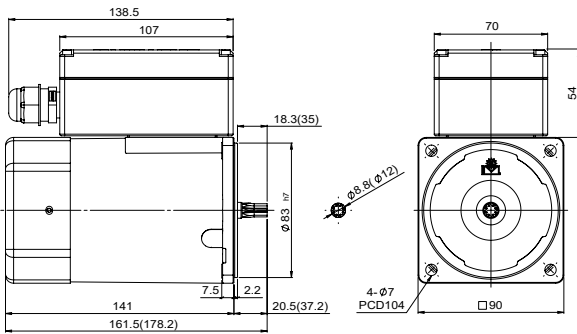

重量 Weight : 3.3kg ±5%

減速機線圖 Gear Head

CG09B □ S □

註：(*) 為 1/90~1/240 之尺寸

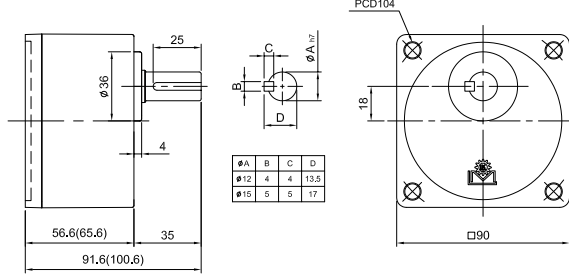

CG09B □ X

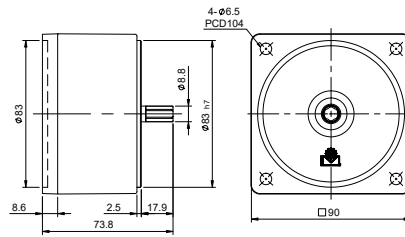

CGCU09B □ S □

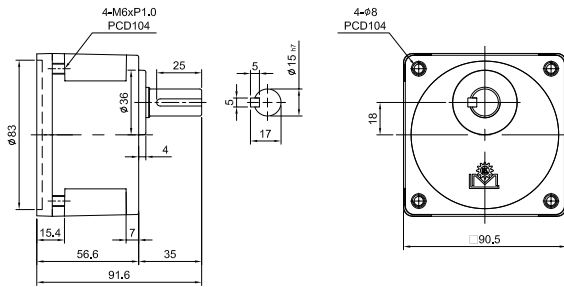

CGU09B □ S □

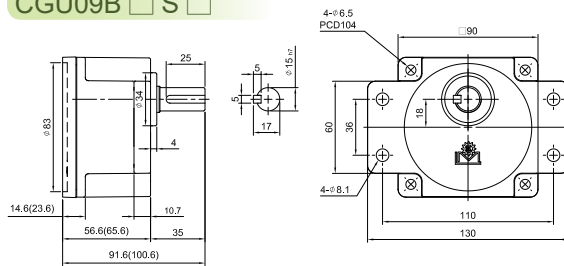

CGB09B □ H □

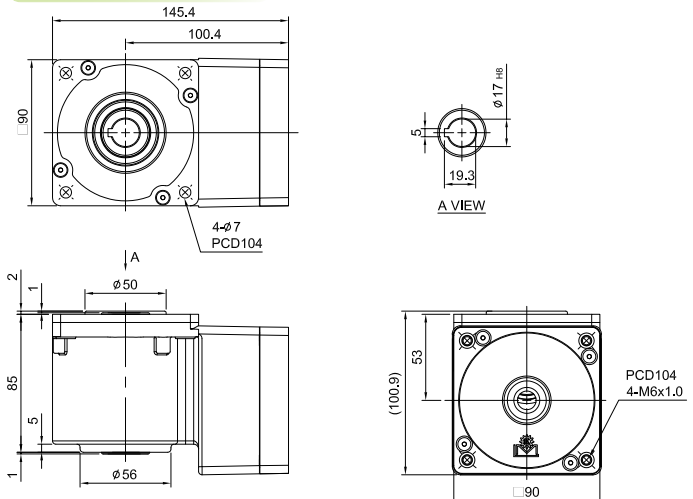

直接連結減速馬達時之容許轉矩 Permissible Torque of Direct Link Gearmotor

輸出功率 Output Power	馬達型號 Motor Model	減速機型號 Reducer Model	減速比 Ratio	轉速 Speed (RPM)		容許 Permissible (kgf·cm)		減速機出力軸旋轉方向 Rotating direction of output shaft of speed reducer
				50Hz	60Hz	50Hz	60Hz	
90W	CM09IG90	CG09 □	3	500	600	18	14	(A) 與馬達同一方向旋轉 Rotating in the same direction as the motor
			5	300	360	28	24	
			6	250	300	34	28	
			7.5	200	240	43	35	
			9	166	200	51	42	
			12.5	120	144	71	60	
			15	100	120	85	70	(B) 與馬達相反方向旋轉 Rotating in the opposite direction to the motor
			18	83	100	96	80	
			25	60	72	125	103	
			30	50	60	150	124	
			36	42	50	178	149	
			50	30	36	200	200	
			60	25	30	200	200	(C) 與馬達同一方向旋轉 Rotating in the same direction as the motor
			75	20	24	200	200	
			90	17	20	200	200	
			100	15	18	200	200	
			120	12.5	15	200	200	
			150	10	12	200	200	
180	8.3	10	200	200				
200	7.5	9	200	200				
240	6.25	7.5	200	200				

直接連結減速馬達時之容許轉矩 (中空軸) Permissible Torque of Direct Link Gearmotor (Hollow Output Shaft)

輸出功率 Output Power	馬達型號 Motor Model	減速機型號 Reducer Model	減速比 Ratio / 頻率 (Hz)	容許轉矩 (kgf·cm)														
				9	15	18	22.5	27	37.5	45	54	75	90	108	150	180		
90W	CM09IG90	CGB09 □	50Hz	轉速 RPM	166	100	83	66	55	40	33	27	20	16	13	10	8.3	
				容許 Nm	4.9	8.2	9.9	12.3	14.8	20.6	24.7	29.7	29.7	29.7	29.7	29.7	29.7	29.7
			60Hz	轉速 RPM	200	120	100	80	66	48	40	33	24	20	16	12	10	
				容許 Nm	4	6.8	8.1	10.2	12.2	17	20.4	24.4	24.4	24.4	24.4	24.4	24.4	24.4
減速機出力軸旋轉方向 Rotating direction of output shaft of speed reducer				(A) 與馬達相反方向旋轉 Rotating in the opposite direction to the motor							(B) 與馬達同一方向旋轉 Rotating in the same direction as the motor							

90W 馬達規格表

框號尺寸 SIZE (mm)	極數 Poles (P)	輸出功率 Output (W)	規格 Type	電壓 Voltage (V)	頻率 Frequency (Hz)	負荷 Duty (min)	額定 Rated Load				啟動電流 Starting Current (A)	啟動轉矩 Starting Torque (kgf·cm)
							輸入功率 Input (W)	電流 Current (A)	轉速 Speed (RPM/min)	轉矩 Torque (kgf·cm)		
90	4	90	CM09IG90TBF CM09IA90TBF	200	50	CONT.	129	0.54	1300	6.7	1.6	18.5
				200	60	CONT.	127	0.49	1550	5.6	1.5	13.6
				220	50	CONT.	126	0.56	1350	6.4	1.8	22.4
				220	60	CONT.	124	0.48	1600	5.6	1.7	16.9
				230	50	CONT.	139	0.6	1350	6.9	1.98	22.2
				230	60	CONT.	121	0.48	1650	5.3	1.8	19
			CM09IG90TCF CM09IA90TCF	380	50	CONT.	138	0.37	1350	6.4	1.1	21
				380	60	CONT.	131	0.3	1600	5.4	1	16
			CM09IG90TJF CM09IA90TJF	200	50	CONT.	149	0.62	1300	7	1.7	16.8
				200	60	CONT.	145	0.56	1550	6	1.5	12.6
				220	50	CONT.	148	0.67	1350	6.4	1.86	20.1
				220	60	CONT.	135	0.54	1600	5.4	1.76	15.4
				230	50	CONT.	159	0.73	1350	6.6	1.9	21.8
				230	60	CONT.	137	0.56	1600	5.4	1.8	16.6
380	50	CONT.	147	0.38	1350	6.5	1	19.4				
380	60	CONT.	130	0.31	1600	5.4	1	16				

如馬達特性變更，恕不另行通知，以馬達銘牌為準。

In case of change of motor characteristics, no further notice shall be given. The information shown on the nameplate of motor is taken as standard.

單相可逆式馬達 Single-Phase Reversible Motor

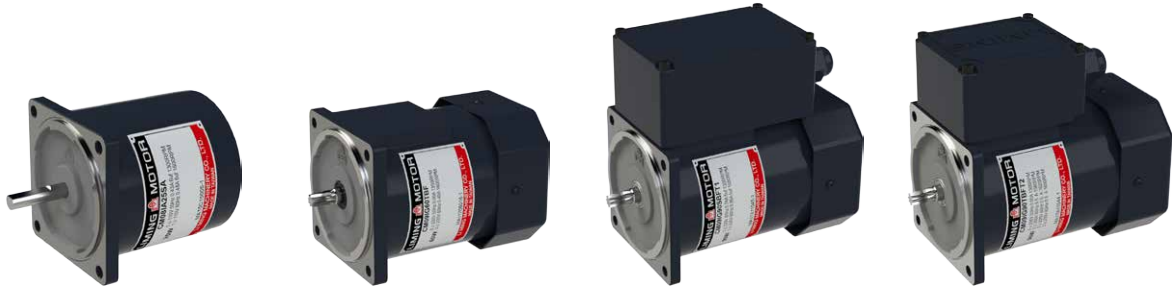

單相可逆式馬達 Single-Phase Reversible Motor

可逆式馬達特徵：適用於單相馬達頻繁正逆轉操作 (30 分鐘額定)。

Characteristics of reversible motor: Applicable to single-phase motor frequently cw / ccw operation (30 minutes rating).

馬達一般規格 Motor General Specification

絕緣阻抗：在馬達的線圈與外殼間以 DC500V 高阻計測定，其數值在 100MΩ 以上。

絕緣耐壓：在馬達的線圈與外殼間施加 50Hz 或 60Hz、1.5KV、1 分鐘無發生異常現象。

溫度上升：於馬達額定運轉後以電阻法測定，溫度上升值在 80°C 以下。

絕緣等級：B 種 (130°C)

保護等級：導線型 IP20，端子盒型 IP54。

使用溫度：-10°C ~+50°C (電容連續運轉馬達 -10°C ~+40°C) (不結凍狀態)。

使用濕度：85% 以下 (不結露狀態)。

Insulation impedance: Measure with DC500V high resistance gauge between the coil and casing of motor, the reading is 100M or higher.

Insulation resistance to pressure: Apply 50Hz or 60Hz, 1.5V between the coil and casing of motor for one minute without irregularity resulted.

Temperature rise: To specify by resistance method after motor reaches rated operation, temperature is less than 80°C .

Insulation: B (130°C)

Protection: Motor with conductive wire is IP20; motor with terminal box is IP54.

Operating temperature: -10°C ~+50°C (Capacitor operation motor -10°C ~+40°C) (No freezing)

Operating humidity: 85% or less (No condensation)

馬達接線圖 Motor Wiring Diagram

◆單相馬達 Single-Phase Motor

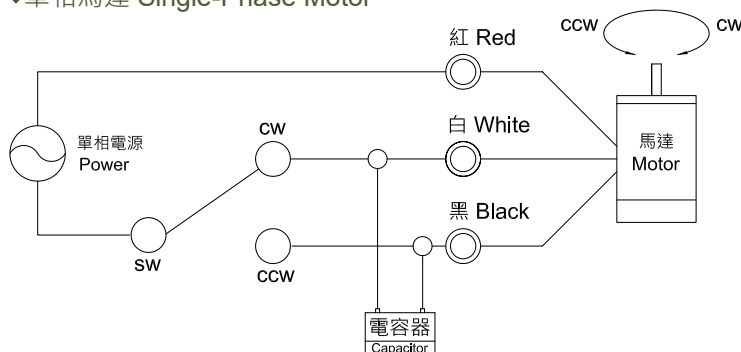

可逆馬達機構 Reversible Motor Machinery

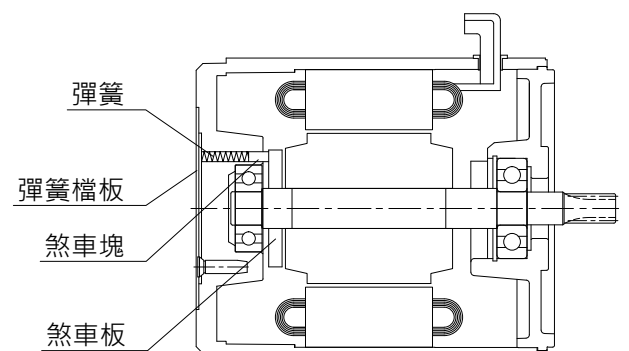

單相可逆馬達 Single Phase Reversible Motor

單相可逆馬達

60 mm
6W

馬達線圖 Motor

CM06 □ 6

註：IA (*) 為 IA 型相關尺寸

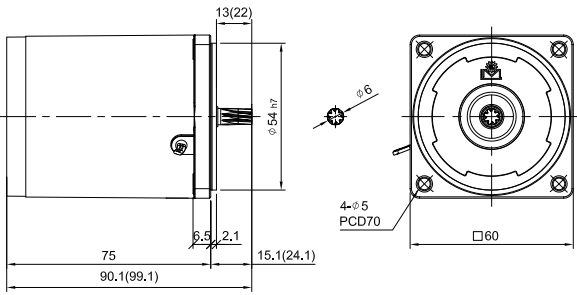

重量 Weight : 0.9kg ±5%

減速機線圖 Gear Head

CG06B □ S □

註：(*) 為 1/90~1/300 之尺寸

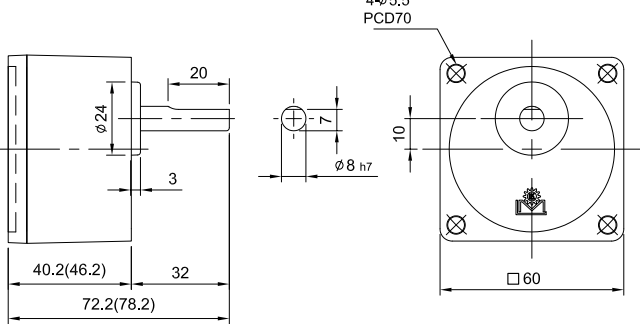

直接連結減速馬達時之容許轉矩 Permissible Torque of Direct Link Gearmotor

輸出功率 Output Power	馬達型號 Motor Model	減速機型號 Reducer Model	減速比 Ratio	轉速 Speed (RPM)		容許 Permissible (kgf·cm)		減速機出力軸旋轉方向 Rotating direction of output shaft of speed reducer
				50Hz	60Hz	50Hz	60Hz	
6W	CM06RG06	CG06 □	3	500	600	1.2	1.0	(A) 與馬達同一方向旋轉 Rotating in the same direction as the motor
			5	300	360	1.9	1.5	
			6	250	300	2.3	1.8	
			7.5	200	240	2.9	2.3	
			9	166	200	3.4	2.8	
			12.5	120	144	4.7	3.9	
			15	100	120	5.7	4.7	(B) 與馬達相反方向旋轉 Rotating in the opposite direction to the motor
			18	83	100	6.8	5.6	
			25	60	72	9.3	7.0	
			30	50	60	11	8.3	
			36	42	50	13	10	
			50	30	36	16	13.8	
			60	25	30	20	16	(C) 與馬達同一方向旋轉 Rotating in the same direction as the motor
			75	20	24	24	20	
			90	17	20	30	24	
			100	15	18	30	30	
			120	12.5	15	30	30	
			150	10	12	30	30	
180	8.3	10	30	30				
200	7.5	9	30	30				
240	6.25	7.5	30	30				
300	5	6	30	30				

6W 可逆馬達規格表

框號尺寸 SIZE (mm)	極數 Poles (P)	輸出功率 Output (W)	規格 Type	電壓 Voltage (V)	頻率 Frequency (Hz)	負荷 Duty (min)	額定 Rated Load				電容器 Capacitor (μ f/V)	啟動電流 Starting Current (A)	啟動轉矩 Starting Torque (kgf·cm)
							輸入功率 Input (W)	電流 Current (A)	轉速 Speed (RPM/min)	轉矩 Torque (kgf·cm)			
60	4	6	CM06RG6SA CM06RA6SA	100	50	30	25	0.25	1300	0.44	4 / 250	0.34	0.54
				100	60	30	26	0.26	1600	0.43	4 / 250	0.35	0.55
				110	50	30	27	0.26	1300	0.42	3 / 250	0.35	0.46
				110	60	30	26	0.24	1600	0.41	3 / 250	0.34	0.48
				120	50	30	33	0.29	1300	0.5	3 / 250	0.38	0.57
				120	60	30	30	0.26	1650	0.35	3 / 250	0.37	0.6
			CM06RG6SB CM06RA6SB	200	50	30	27	0.13	1300	0.4	1.2 / 450	0.15	0.85
				200	60	30	33	0.16	1500	0.39	1.2 / 450	0.17	0.7
				220	50	30	32	0.15	1300	0.4	1.2 / 450	0.12	0.48
				220	60	30	40	0.18	1550	0.37	1.2 / 450	0.17	1
				230	50	30	23	0.1	1300	0.45	0.8 / 450	0.13	0.73
				230	60	30	28	0.12	1600	0.36	0.8 / 450	0.15	0.75
				240	50	30	25	0.1	1300	0.4	0.8 / 450	0.14	0.8
				240	60	30	30	0.12	1600	0.4	0.8 / 450	0.15	0.84

如馬達特性變更，恕不另行通知，以馬達銘牌為準。

In case of change of motor characteristics, no further notice shall be given. The information shown on the nameplate of motor is taken as standard.

馬達線圖 Motor

CM07 □ 15

註：IA (*) 為 IA 型相關尺寸

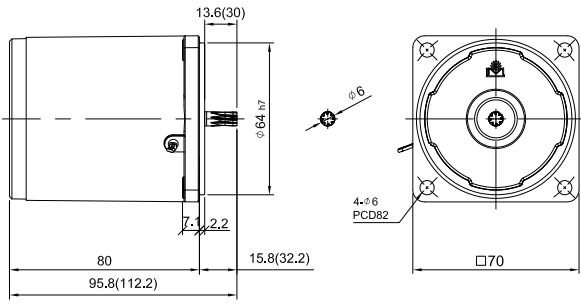

重量 Weight : 1.5kg ±5%

減速機線圖 Gear Head

CG07B □ S □

註：(*) 為 1/90~1/240 之尺寸

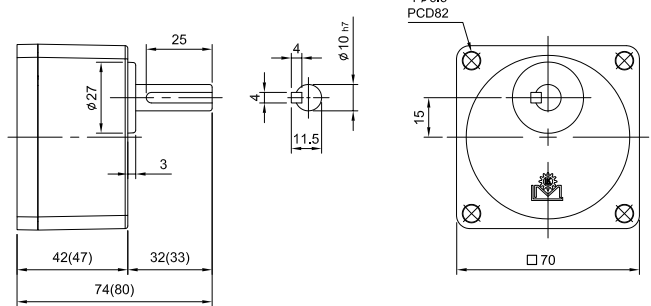

直接連結減速馬達時之容許轉矩 Permissible Torque of Direct Link Gearmotor

輸出功率 Output Power	馬達型號 Motor Model	減速機型號 Reducer Model	減速比 Ratio	轉速 Speed (RPM)		容許 Permissible (kgf·cm)		減速機出力軸旋轉方向 Rotating direction of output shaft of speed reducer
				50Hz	60Hz	50Hz	60Hz	
15W	CM07RG15	CG07 □	3	500	600	3.0	2.6	(A) 與馬達同一方向旋轉 Rotating in the same direction as the motor
			5	300	360	4.7	3.9	
			6	250	300	5.7	4.7	
			7.5	200	240	7.1	5.8	
			9	166	200	8.5	7.0	
			12.5	120	144	11.8	9.8	
			15	100	120	14.2	11.8	(B) 與馬達相反方向旋轉 Rotating in the opposite direction to the motor
			18	83	100	18	15	
			25	60	72	23	19	
			30	50	60	28	23	
			36	42	50	33	27.6	
			50	30	36	46	38.4	
			60	25	30	50	46	(C) 與馬達同一方向旋轉 Rotating in the same direction as the motor
			75	20	24	50	50	
			90	17	20	50	50	
			100	15	18	50	50	
			120	12.5	15	50	50	
			150	10	12	50	50	
180	8.3	10	50	50				
200	7.5	9	50	50				
240	6.25	7.5	50	50				
300	5	6	-	-				

15W 可逆馬達規格表

框號尺寸 SIZE (mm)	極數 Poles (P)	輸出功率 Output (W)	規格 Type	電壓 Voltage (V)	頻率 Frequency (Hz)	負荷 Duty (min)	額定 Rated Load				電容器 Capacitor (μf/V)	啟動電流 Starting Current (A)	啟動轉矩 Starting Torque (kgf·cm)
							輸入功率 Input (W)	電流 Current (A)	轉速 Speed (RPM/min)	轉矩 Torque (kgf·cm)			
70	4	15	CM07RG15SA CM07RA15SA	100	50	30	37	0.39	1250	1.1	6 / 250	0.6	0.98
				100	60	30	36	0.36	1600	0.91	6 / 250	0.57	0.99
				110	50	30	42	0.41	1300	1.1	6 / 250	0.66	1.1
				110	60	30	43	0.39	1600	1	6 / 250	0.63	1.2
				120	50	30	47	0.46	1300	1.12	5 / 250	0.71	1.1
				120	60	30	44	0.38	1600	1	5 / 250	0.66	1.1
			CM07RG15SB CM07RA15SB	200	50	30	44	0.23	1300	1	2 / 450	0.35	1.35
				200	60	30	48	0.24	1600	0.96	2 / 450	0.35	1.35
				220	50	30	50	0.24	1250	1	1.5 / 450	0.37	1
				220	60	30	47	0.22	1550	1	1.5 / 450	0.35	1
				230	50	30	54	0.26	1250	1.1	1.5 / 450	0.39	1.23
				230	60	30	49	0.21	1600	0.92	1.5 / 450	0.36	1.12
				240	50	30	58	0.28	1300	1.1	1.5 / 450	0.4	1.3
				240	60	30	51	0.23	1600	0.9	1.5 / 450	0.38	1.3

如馬達特性變更，恕不另行通知，以馬達銘牌為準。

In case of change of motor characteristics, no further notice shall be given. The information shown on the nameplate of motor is taken as standard.

馬達線圖 Motor

CM08 □ 25

註：IA (*) 為 IA 型相關尺寸

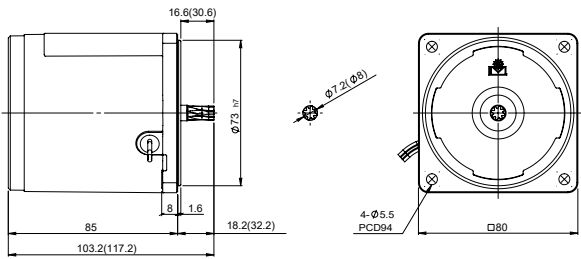

重量 Weight : 1.5kg ±5%

CM08 □ 25F

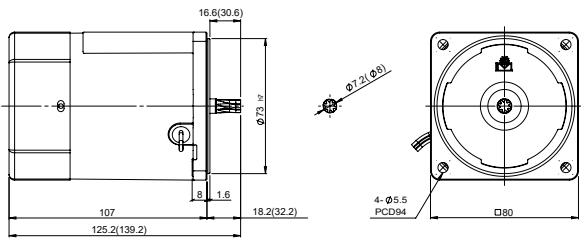

重量 Weight : 1.6kg ±5%

CM08 □ 25T

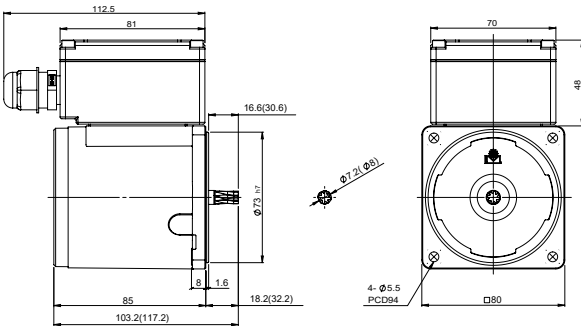

重量 Weight : 2kg ±5%

CM08 □ 25T1

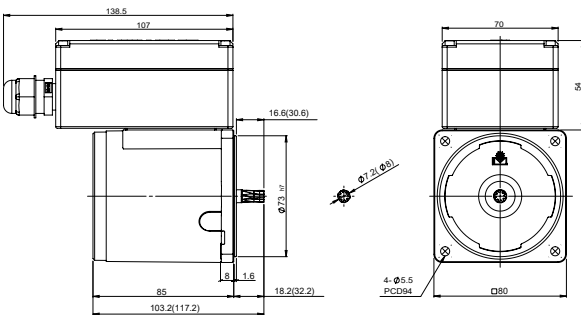

重量 Weight : 1.7kg ±5%

減速機線圖 Gear Head

CG08B □ S □

註：(*) 為 1/90~1/300 之尺寸

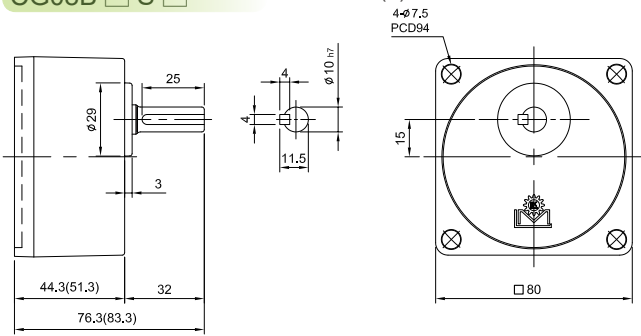

CG08B □ X

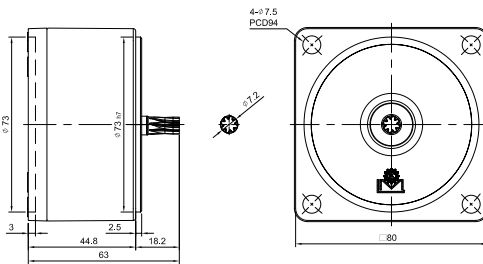

直接連結減速馬達時之容許轉矩 Permissible Torque of Direct Link Gearmotor

輸出功率 Output Power	馬達型號 Motor Model	減速機型號 Reducer Model	減速比 Ratio	轉速 Speed (RPM)		容許 Permissible (kgf·cm)		減速機出力軸旋轉方向 Rotating direction of output shaft of speed reducer
				50Hz	60Hz	50Hz	60Hz	
25W	CM08RG25	CG08 □	3	500	600	5.0	4.1	(A) 與馬達同一方向旋轉 Rotating in the same direction as the motor
			5	300	360	7.8	6.3	
			6	250	300	9.4	7.6	
			7.5	200	240	11.8	9.5	
			9	166	200	14.1	11.4	
			12.5	120	144	19.6	16	
			15	100	120	23	19	
			18	83	100	28	23	(B) 與馬達相反方向旋轉 Rotating in the opposite direction to the motor
			25	60	72	38	31	
			30	50	60	46	37	
			36	42	50	55	45	
			50	30	36	76	62	
			60	25	30	80	75	
			75	20	24	80	80	
			90	17	20	80	80	(C) 與馬達同一方向旋轉 Rotating in the same direction as the motor
			100	15	18	80	80	
			120	12.5	15	80	80	
			150	10	12	80	80	
			180	8.3	10	80	80	
200	7.5	9	80	80				
240	6.25	7.5	80	80				
300	5	6	80	80				

25W 可逆馬達規格表

框號尺寸 SIZE (mm)	極數 Poles (P)	輸出功率 Output (W)	規格 Type	電壓 Voltage (V)	頻率 Frequency (Hz)	負荷 Duty (min)	額定 Rated Load				電容器 Capacitor (μ f / V)	啟動電流 Starting Current (A)	啟動轉矩 Starting Torque (kgf·cm)
							輸入功率 Input (W)	電流 Current (A)	轉速 Speed (RPM/min)	轉矩 Torque (kgf·cm)			
80	4	25	CM08RG25SA CM08RA25SA	110	50	30	59	0.5	1300	1.9	8 / 250	0.92	1.9
				110	60	30	58	0.53	1550	1.5	8 / 250	0.89	1.9
				120	50	30	68	0.59	1250	2	8 / 250	1	2.2
				120	60	30	68	0.57	1600	1.5	8 / 250	0.96	2.4
			CM08RG25SB CM08RA25SB	220	50	30	59	0.27	1250	1.9	2 / 450	0.46	1.9
				220	60	30	58	0.26	1550	1.5	2 / 450	0.44	2
				230	50	30	60	0.27	1250	1.9	2 / 450	0.48	1.9
				230	60	30	61	0.26	1600	1.5	2 / 450	0.46	2.1
				240	50	30	63	0.27	1300	1.8	2 / 450	0.49	2.2
				240	60	30	65	0.27	1600	1.5	2 / 450	0.48	2.2

如馬達特性變更，恕不另行通知，以馬達銘牌為準。

In case of change of motor characteristics, no further notice shall be given. The information shown on the nameplate of motor is taken as standard.

馬達線圖 Motor

CM09 □ 40

註：IA (*) 為 IA 型相關尺寸

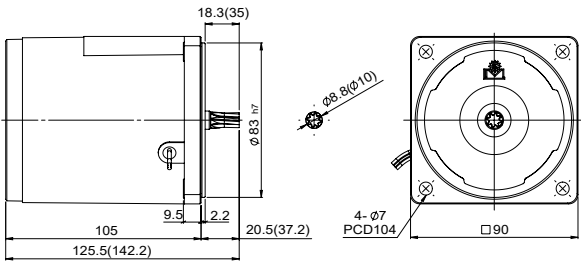

重量 Weight : 2.3kg ±5%

CM09 □ 40T

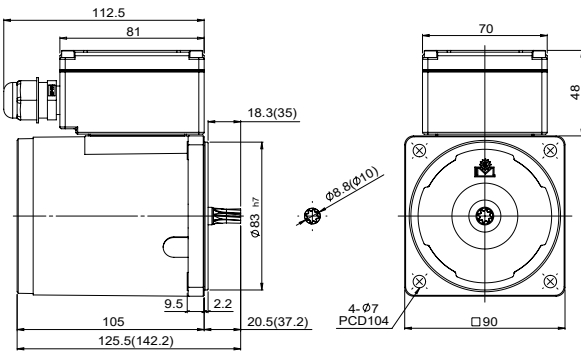

重量 Weight : 2.7kg ±5%

CM09 □ 40T1

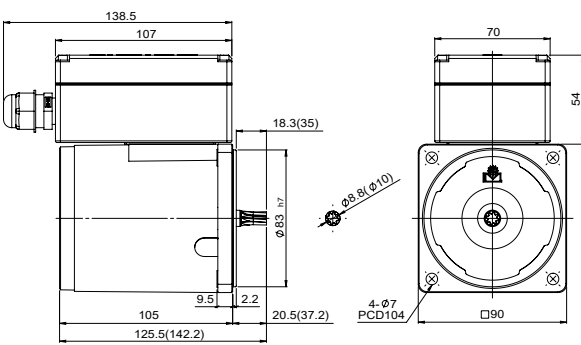

重量 Weight : 2.5kg ±5%

減速機線圖 Gear Head

CG09B □ S □

註：(*) 為 1/90~1/240 之尺寸

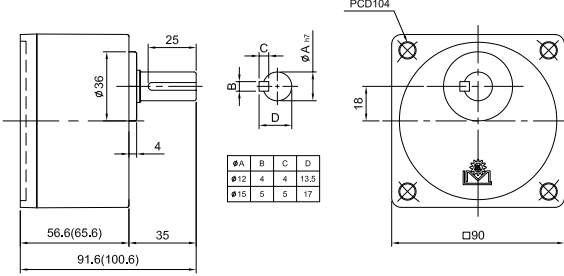

CG09B □ X

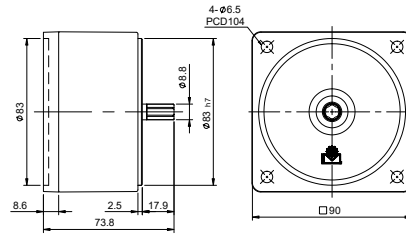

CGCU09B □ S □

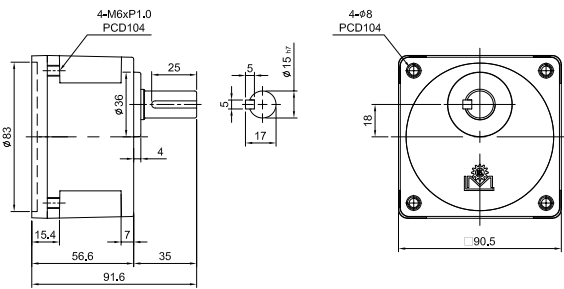

CGU09B □ S □

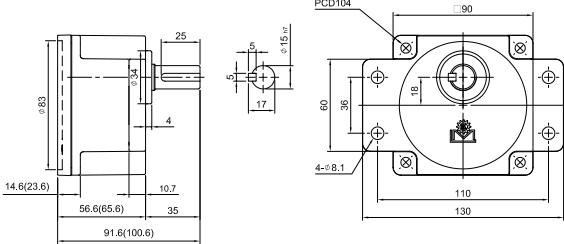

CGB09B □ H □

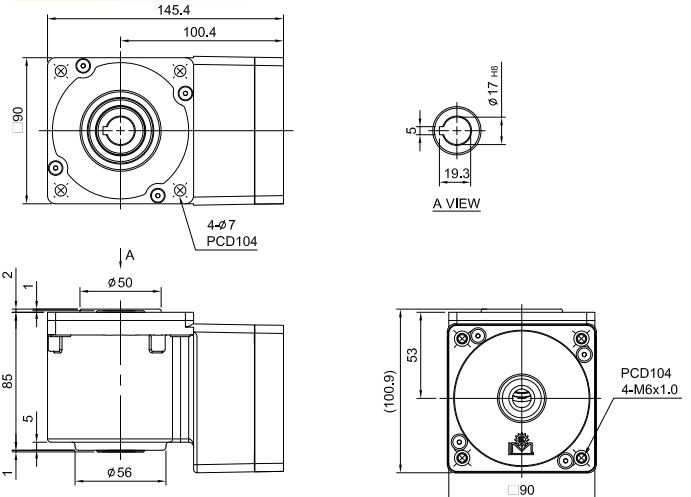

直接連結減速馬達時之容許轉矩 Permissible Torque of Direct Link Gearmotor

輸出功率 Output Power	馬達型號 Motor Model	減速機型號 Reducer Model	減速比 Ratio	轉速 Speed (RPM)		容許 Permissible (kgf-cm)		減速機出力軸旋轉方向 Rotating direction of output shaft of speed reducer
				50Hz	60Hz	50Hz	60Hz	
40W	CM09RG40	CG09 □	3	500	600	7.3	6.3	(A) 與馬達同一方向旋轉 Rotating in the same direction as the motor
			5	300	360	12	10	
			6	250	300	14.7	12	
			7.5	200	240	18	15	
			9	166	200	22	19	
			12.5	120	144	30	26	
			15	100	120	36	30	(B) 與馬達相反方向旋轉 Rotating in the opposite direction to the motor
			18	83	100	43	37	
			25	60	72	54	45	
			30	50	60	65	54	
			36	42	50	77	65	
			50	30	36	100	90	
			60	25	30	100	100	(C) 與馬達同一方向旋轉 Rotating in the same direction as the motor
			75	20	24	100	100	
			90	17	20	100	100	
			100	15	18	100	100	
			120	12.5	15	100	100	
			150	10	12	100	100	
180	8.3	10	100	100				
200	7.5	9	100	100				
240	6.25	7.5	100	100				

直接連結減速馬達時之容許轉矩 (中空軸) Permissible Torque of Direct Link Gearmotor (Hollow Output Shaft)

輸出功率 Output Power	馬達型號 Motor Model	減速機型號 Reducer Model	減速比 Ratio / 頻率 (Hz)	轉速 RPM															
				9	15	18	22.5	27	37.5	45	54	75	90	108	150	180			
40W	CM09RG40	CGB09 □	50Hz	轉速 RPM	166	100	83	66	55	40	33	27	20	16	13	10	8.3		
				容許 Nm	2	3.4	4	5.1	6.1	8.5	10.2	12.2	12.2	12.2	12.2	12.2	12.2	12.2	
			60Hz	轉速 RPM	200	120	100	80	66	48	40	33	24	20	16	12	10		
				容許 Nm	1.6	2.7	3.3	4.1	5	6.9	8.3	10	10	10	10	10	10	10	
減速機出力軸旋轉方向 Rotating direction of output shaft of speed reducer				(A) 與馬達相反方向旋轉 Rotating in the opposite direction to the motor								(B) 與馬達同一方向旋轉 Rotating in the same direction as the motor							

40W 可逆馬達規格表

框號尺寸 SIZE (mm)	極數 Poles (P)	輸出功率 Output (W)	規格 Type	電壓 Voltage (V)	頻率 Frequency (Hz)	負荷 Duty (min)	額定 Rated Load				電容器 Capacitor (μf/V)	啟動電流 Starting Current (A)	啟動轉矩 Starting Torque (kgf-cm)
							輸入功率 Input (W)	電流 Current (A)	轉速 Speed (RPM/min)	轉矩 Torque (kgf-cm)			
90	4	40	CM09RG40SA CM09RA40SA	100	50	30	77	0.8	1350	3	12 / 250	1.8	2.3
				100	60	30	76	0.7	1650	2.7	12 / 250	1.7	2.2
				110	50	30	87	0.85	1650	3	12 / 250	2	2.6
				110	60	30	99	0.9	1600	3.6	12 / 250	1.8	2.8
			CM09RG40SB CM09RA40SB	200	50	30	199	0.38	1250	3	3 / 450	0.55	2.2
				200	60	30	199	0.45	1550	2.4	3 / 450	0.54	2.3
				220	50	30	80	0.37	1300	3	3 / 450	0.6	2.8
				220	60	30	96	0.47	1600	2.5	3 / 450	0.6	3
				230	50	30	87	0.38	1300	3.4	3 / 450	0.64	3
				230	60	30	102	0.47	1600	2.5	3 / 450	0.62	3.3
				240	50	30	92	0.4	1300	3.5	3 / 450	0.66	3.5
				240	60	30	107	0.48	1600	2.5	3 / 450	0.65	3.4

如馬達特性變更，恕不另行通知，以馬達銘牌為準。

In case of change of motor characteristics, no further notice shall be given. The information shown on the nameplate of motor is taken as standard.

馬達線圖 Motor

CM09 □ 60F

註：IA (*) 為 IA 型相關尺寸

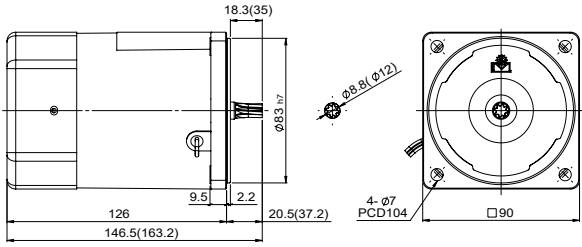

重量 Weight : 2.5kg ±5%

CM09 □ 60 □ FT

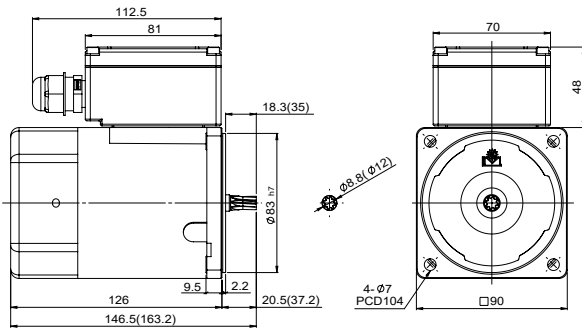

重量 Weight : 2.8kg ±5%

CM09 □ 60 □ FT1

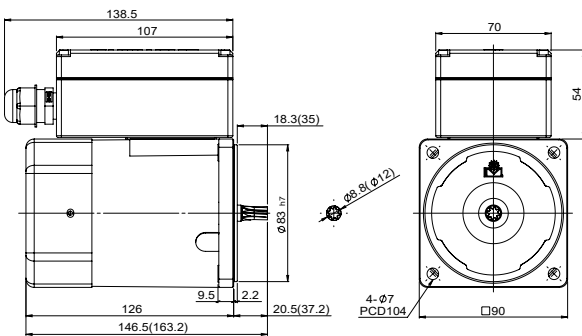

重量 Weight : 2.7kg ±5%

減速機線圖 Gear Head

CG09B □ S □

註：(*) 為 1/90~1/240 之尺寸

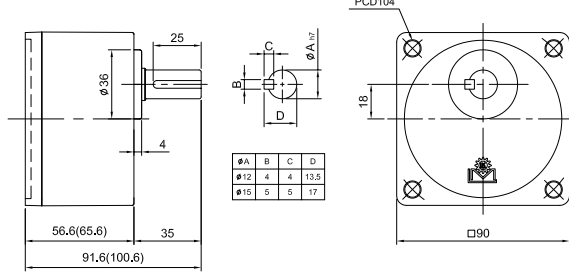

CG09B □ X

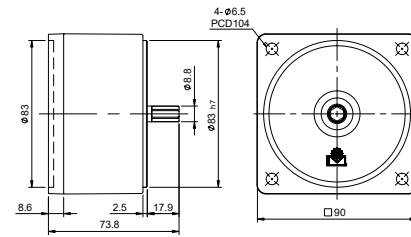

CGCU09B □ S □

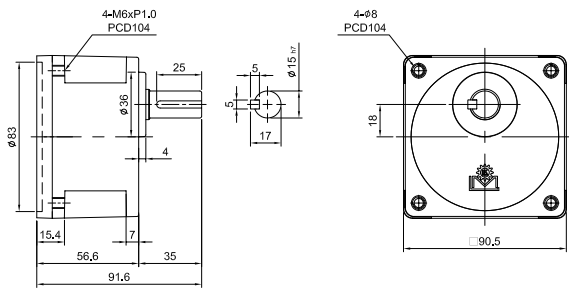

CGU09B □ S □

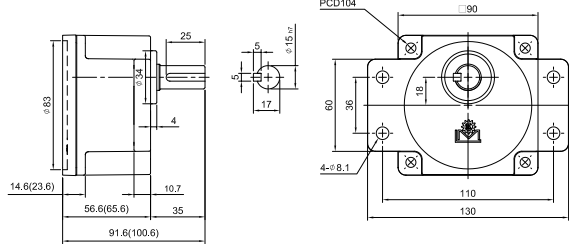

CGB09B □ H □

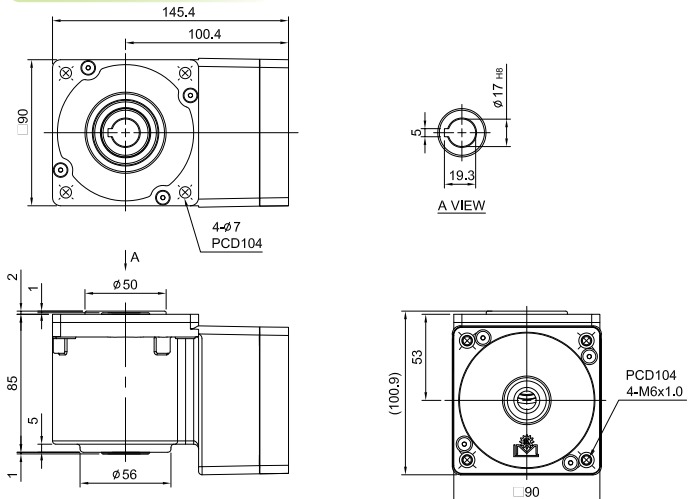

直接連結減速馬達時之容許轉矩 Permissible Torque of Direct Link Gearmotor

輸出功率 Output Power	馬達型號 Motor Model	減速機型號 Reducer Model	減速比 Ratio	轉速 Speed (RPM)		容許 Permissible (kgf-cm)		減速機出力軸旋轉方向 Rotating direction of output shaft of speed reducer
				50Hz	60Hz	50Hz	60Hz	
60W	CM09RG60	CG09 □	3	500	600	12	9.8	(A) 與馬達同一方向旋轉 Rotating in the same direction as the motor
			5	300	360	19	16	
			6	250	300	22	19	
			7.5	200	240	28	24	
			9	166	200	34	28	
			12.5	120	144	48	40	
			15	100	120	55	47	
			18	83	100	62	55	
			25	60	72	82	69	
			30	50	60	98	83	
			36	42	50	118	100	(B) 與馬達相反方向旋轉 Rotating in the opposite direction to the motor
			50	30	36	164	138	
			60	25	30	196	160	
			75	20	24	200	175	
			90	17	20	200	200	
			100	15	18	200	200	
			120	12.5	15	200	200	
			150	10	12	200	200	
			180	8.3	10	200	200	
			200	7.5	9	200	200	
240	6.25	7.5	200	200	(C) 與馬達同一方向旋轉 Rotating in the same direction as the motor			

直接連結減速馬達時之容許轉矩 (中空軸) Permissible Torque of Direct Link Gearmotor (Hollow Output Shaft)

輸出功率 Output Power	馬達型號 Motor Model	減速機型號 Reducer Model	減速比 Ratio / 頻率 (Hz)	轉速 Speed (RPM)															
				9	15	18	22.5	27	37.5	45	54	75	90	108	150	180			
60W	CM09RG60	CGB09 □	50Hz	轉速 RPM	166	100	83	66	55	40	33	27	20	16	13	10	8.3		
				容許 Nm	3.2	5.4	6.5	8.2	9.8	13.6	16.4	19.6	19.6	19.6	19.6	19.6	19.6	19.6	
			60Hz	轉速 RPM	200	120	100	80	66	48	40	33	24	20	16	12	10		
				容許 Nm	2.6	4.3	5.2	6.5	7.8	10.9	13.1	15.7	15.7	15.7	15.7	15.7	15.7	15.7	
減速機出力軸旋轉方向 Rotating direction of output shaft of speed reducer				(A) 與馬達相反方向旋轉 Rotating in the opposite direction to the motor								(B) 與馬達同一方向旋轉 Rotating in the same direction as the motor							

60W 可逆馬達規格表

框號尺寸 SIZE (mm)	極數 Poles (P)	輸出功率 Output (W)	規格 Type	電壓 Voltage (V)	頻率 Frequency (Hz)	負荷 Duty (min)	額定 Rated Load				電容器 Capacitor (μf / V)	啟動電流 Starting Current (A)	啟動轉矩 Starting Torque (kgf-cm)
							輸入功率 Input (W)	電流 Current (A)	轉速 Speed (RPM/min)	轉矩 Torque (kgf-cm)			
90	4	60	CM09RG60SAF CM09RA60SAF	100	50	30	115	1.2	1250	4.6	20 / 250	1.6	3.7
				100	60	30	131	1.3	1550	3.6	20 / 250	1.6	3.8
				110	50	30	120	1.1	1300	4.5	20 / 250	1.7	4.4
				110	60	30	145	1.4	1600	3.6	20 / 250	1.8	4.7
				120	50	30	135	1.1	1350	4.3	20 / 250	1.9	5
				120	60	30	164	1.5	1650	3.4	20 / 250	2	5.4
			CM09RG60SBF CM09RA60SBF	200	50	30	105	0.5	1300	4.5	4 / 450	1	3.2
				200	60	30	108	0.5	1600	3.7	4 / 450	1	3.2
				220	50	30	110	0.5	1350	4.4	4 / 450	1	3.7
				220	60	30	113	0.5	1650	3.5	4 / 450	1	3.7
				230	50	30	118	0.5	1350	4.4	4 / 450	1	4
				230	60	30	118	0.5	1650	3.5	4 / 450	1	4
				240	50	30	128	0.5	1350	4.5	4 / 450	1	4.4
				240	60	30	128	0.5	1650	3.7	4 / 450	1	4.7

如馬達特性變更，恕不另行通知，以馬達銘牌為準。

In case of change of motor characteristics, no further notice shall be given. The information shown on the nameplate of motor is taken as standard.

馬達線圖 Motor

CM09 □ 90F

註：IA (*) 為 IA 型相關尺寸

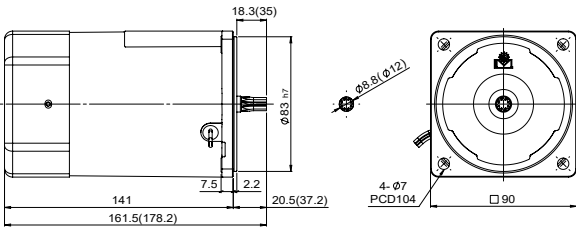

重量 Weight : 3.1kg ±5%

CM09 □ 90FT

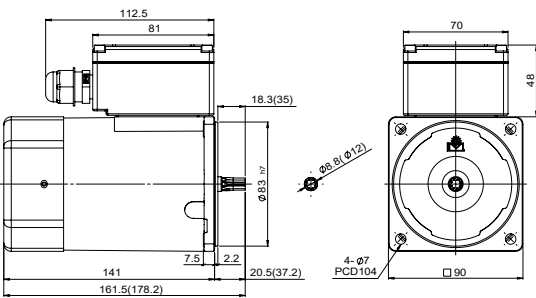

重量 Weight : 3.5kg ±5%

CM09 □ 90FT1

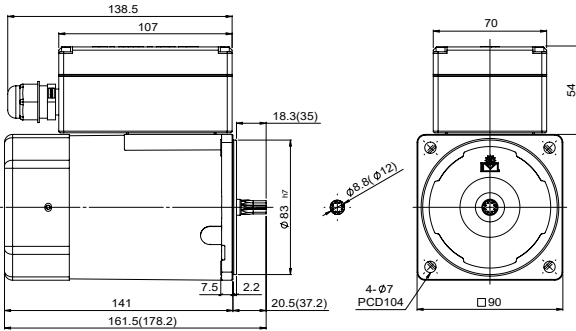

重量 Weight : 3.3kg ±5%

減速機線圖 Gear Head

CG09B □ S □

註：(*) 為 1/90~1/240 之尺寸

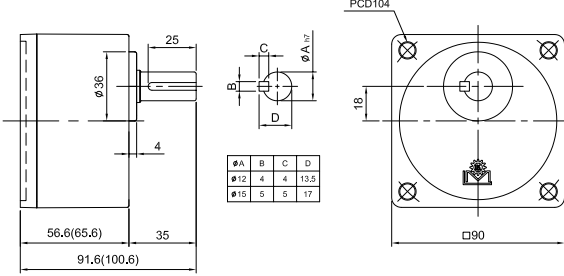

CG09B □ X

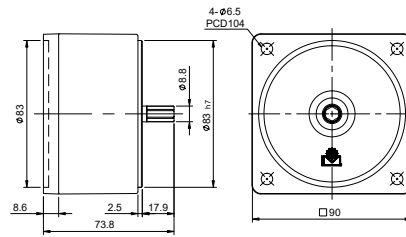

CGCU09B □ S □

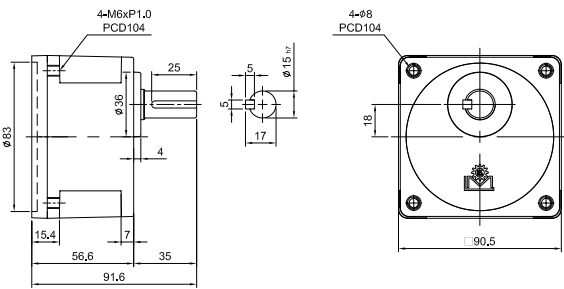

CGU09B □ S □

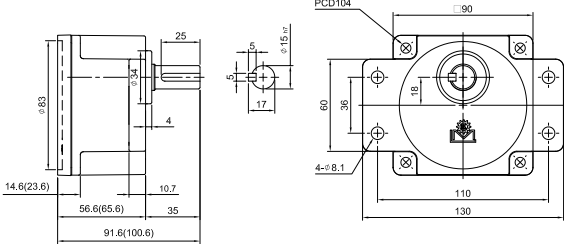

CGB09B □ H □

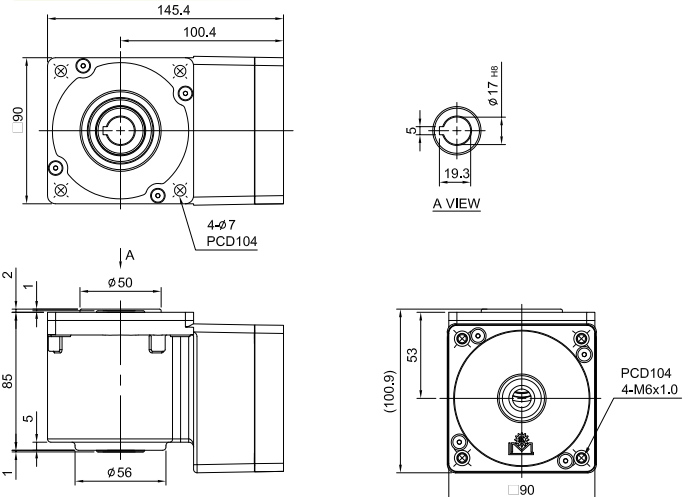

直接連結減速馬達時之容許轉矩 Permissible Torque of Direct Link Gearmotor

輸出功率 Output Power	馬達型號 Motor Model	減速機型號 Reducer Model	減速比 Ratio	轉速 Speed (RPM)		容許 Permissible (kgf·cm)		減速機出力軸旋轉方向 Rotating direction of output shaft of speed reducer
				50Hz	60Hz	50Hz	60Hz	
90W	CM09RG90	CG09 □	3	500	600	18	14	(A) 與馬達同一方向旋轉 Rotating in the same direction as the motor
			5	300	360	28	24	
			6	250	300	34	28	
			7.5	200	240	43	35	
			9	166	200	51	42	
			12.5	120	144	71	60	
			15	100	120	85	70	
			18	83	100	96	80	
			25	60	72	125	103	
			30	50	60	150	124	
			36	42	50	178	149	(B) 與馬達相反方向旋轉 Rotating in the opposite direction to the motor
			50	30	36	200	200	
			60	25	30	200	200	
			75	20	24	200	200	
			90	17	20	200	200	
			100	15	18	200	200	
			120	12.5	15	200	200	(C) 與馬達同一方向旋轉 Rotating in the same direction as the motor
			150	10	12	200	200	
			180	8.3	10	200	200	
			200	7.5	9	200	200	
			240	6.25	7.5	200	200	

直接連結減速馬達時之容許轉矩 (中空軸) Permissible Torque of Direct Link Gearmotor (Hollow Output Shaft)

輸出功率 Output Power	馬達型號 Motor Model	減速機型號 Reducer Model	減速比 Ratio / 頻率 (Hz)	轉速 RPM															
				9	15	18	22.5	27	37.5	45	54	75	90	108	150	180			
90W	CM09IG90	CGB09 □	50Hz	轉速 RPM	166	100	83	66	55	40	33	27	20	16	13	10	8.3		
				容許 Nm	4.8	8	9.6	12	14.4	20	24	28.8	28.8	28.8	28.8	28.8	28.8	28.8	
			60Hz	轉速 RPM	200	120	100	80	66	48	40	33	24	20	16	12	10		
				容許 Nm	3.9	6.5	7.8	9.8	11.8	16.4	19.6	23.6	23.6	23.6	23.6	23.6	23.6	23.6	
減速機出力軸旋轉方向 Rotating direction of output shaft of speed reducer				(A) 與馬達相反方向旋轉 Rotating in the opposite direction to the motor								(B) 與馬達同一方向旋轉 Rotating in the same direction as the motor							

90W 可逆馬達規格表

框號尺寸 SIZE (mm)	極數 Poles (P)	輸出功率 Output (W)	規格 Type	電壓 Voltage (V)	頻率 Frequency (Hz)	負荷 Duty (min)	額定 Rated Load				電容器 Capacitor (μf/V)	啟動電流 Starting Current (A)	啟動轉矩 Starting Torque (kgf·cm)
							輸入功率 Input (W)	電流 Current (A)	轉速 Speed (RPM/min)	轉矩 Torque (kgf·cm)			
90	4	90	CM09RG90SAF CM09RA90SAF	100	50	30	147	1.5	1300	6.7	24 / 250	2.5	4.7
				100	60	30	160	1.6	1600	5.6	24 / 250	2.4	4.8
				110	50	30	155	1.4	1350	6.6	24 / 250	2.7	5.7
				110	60	30	170	1.6	1650	5.4	24 / 250	2.7	5.8
				120	50	30	173	1.5	1350	6.5	24 / 250	3	6.8
				120	60	30	190	1.7	1650	5.3	24 / 250	3	7.2
			CM09RG90SBF CM09RA90SBF	200	50	30	142	0.7	1300	6.7	6 / 450	1.2	5
				200	60	30	160	0.8	1600	5.6	6 / 450	1.2	5.3
				220	50	30	151	0.7	1350	6.5	6 / 450	1.3	6.1
				220	60	30	173	0.8	1600	5.4	6 / 450	1.3	6.3
				230	50	30	157	0.7	1350	6.5	6 / 450	1.4	6.6
				230	60	30	180	0.8	1650	5.2	6 / 450	1.4	6.9
				240	50	30	163	0.7	1350	6.5	6 / 450	1.4	7.4
				240	60	30	188	0.8	1650	5.3	6 / 450	1.4	7.6

如馬達特性變更，恕不另行通知，以馬達銘牌為準。

In case of change of motor characteristics, no further notice shall be given. The information shown on the nameplate of motor is taken as standard.

三相可逆式馬達 3-Phase Reversible Motor

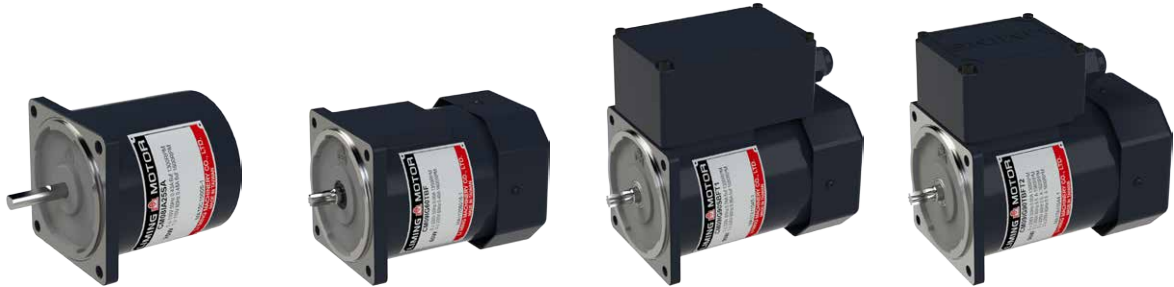

■ 三相可逆式馬達 3-Phase Reversible Motor

可逆式馬達特徵：適用於三相馬達頻繁正逆轉操作 (30 分鐘額定)。

Characteristics of reversible motor: Applicable to 3-phase motor frequently cw / ccw operation (30 minutes rating).

■ 馬達一般規格 Motor General Specification

絕緣阻抗：在馬達的線圈與外殼間以 DC500V 高阻計測定，其數值在 100MΩ 以上。

絕緣耐壓：在馬達的線圈與外殼間施加 50Hz 或 60Hz、1.5KV、1 分鐘無發生異常現象。

溫度上升：於馬達額定運轉後以電阻法測定，溫度上升值在 80°C 以下。

絕緣等級：B 種 (130°C)

保護等級：導線型 IP20，端子盒型 IP54。

使用溫度：-10°C ~+50°C (電容連續運轉馬達 -10°C ~+40°C) (不結凍狀態)。

使用濕度：85% 以下 (不結露狀態)。

Insulation impedance: Measure with DC500V high resistance gauge between the coil and casing of motor, the reading is 100M or higher.

Insulation resistance to pressure: Apply 50Hz or 60Hz, 1.5KV between the coil and casing of motor for one minute without irregularity resulted.

Temperature rise: To specify by resistance method after motor reaches rated operation, temperature is less than 80°C .

Insulation: B (130°C)

Protection: Motor with conductive wire is IP20; motor with terminal box is IP54.

Operating temperature: -10°C ~+50°C (Capacitor operation motor -10°C ~+40°C) (No freezing)

Operating humidity: 85% or less (No condensation)

■ 馬達接線圖 Motor Wiring Diagram

◆ 三相馬達 3-Phase Motor

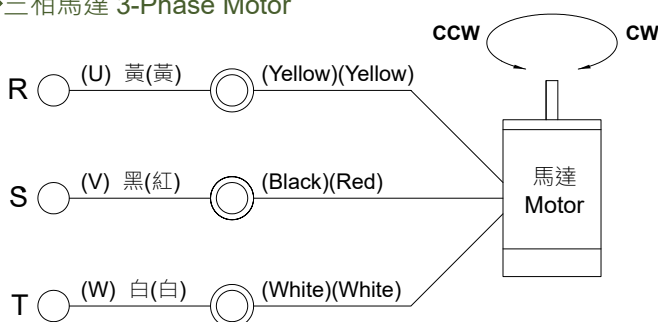

■ 可逆馬達機構 Reversible Motor Machinery

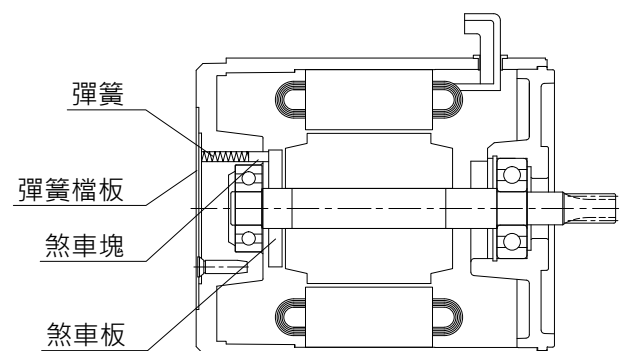

馬達線圖 Motor

CM08 □ 25

註：IA (*) 為 IA 型相關尺寸

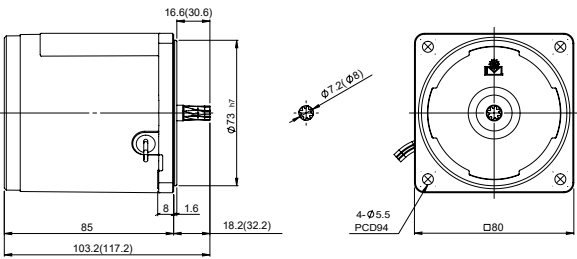

重量 Weight : 1.5kg ±5%

CM08 □ 25F

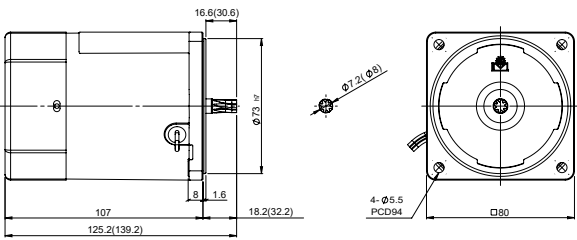

重量 Weight : 1.6kg ±5%

CM08 □ 25T

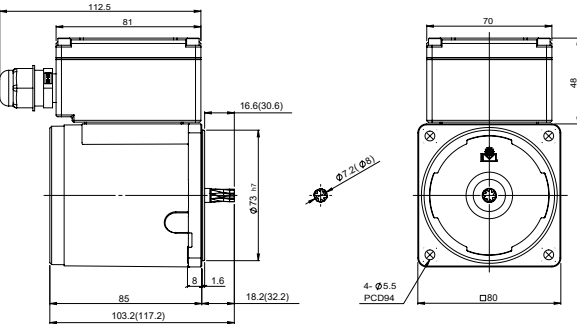

重量 Weight : 2kg ±5%

CM08 □ 25T1

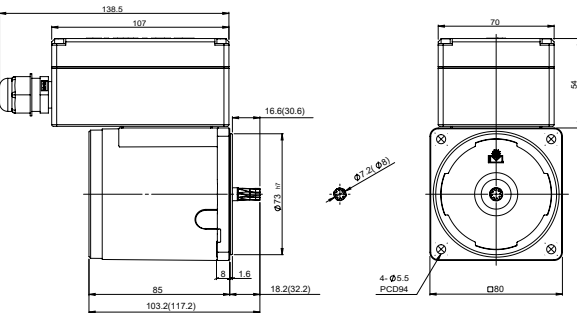

重量 Weight : 1.7kg ±5%

減速機線圖 Gear Head

CG08B □ S □

註：(*) 為 1/90~1/300 之尺寸

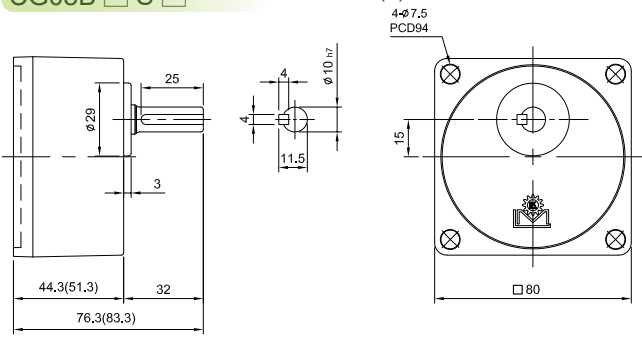

CG08B □ X

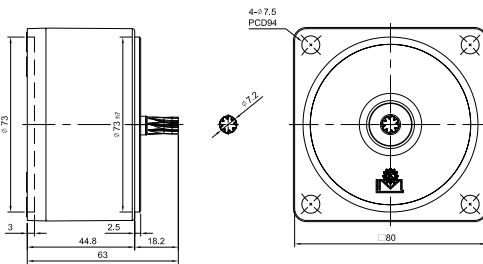

直接連結減速馬達時之容許轉矩 Permissible Torque of Direct Link Gearmotor

輸出功率 Output Power	馬達型號 Motor Model	減速機型號 Reducer Model	減速比 Ratio	轉速 Speed (RPM)		容許 Permissible (kgf·cm)		減速機出力軸旋轉方向 Rotating direction of output shaft of speed reducer
				50Hz	60Hz	50Hz	60Hz	
25W	CM08RG25	CG08 □	3	500	600	5.0	4.1	(A) 與馬達同一方向旋轉 Rotating in the same direction as the motor
			5	300	360	7.8	6.3	
			6	250	300	9.4	7.6	
			7.5	200	240	11.8	9.5	
			9	166	200	14.1	11.4	
			12.5	120	144	19.6	16	
			15	100	120	23	19	
			18	83	100	28	23	
			25	60	72	38	31	(B) 與馬達相反方向旋轉 Rotating in the opposite direction to the motor
			30	50	60	46	37	
			36	42	50	55	45	
			50	30	36	76	62	
			60	25	30	80	75	
			75	20	24	80	80	
			90	17	20	80	80	(C) 與馬達同一方向旋轉 Rotating in the same direction as the motor
			100	15	18	80	80	
			120	12.5	15	80	80	
			150	10	12	80	80	
			180	8.3	10	80	80	
			200	7.5	9	80	80	
240	6.25	7.5	80	80				
300	5	6	80	80				

25W 可逆馬達規格表

框號尺寸 SIZE (mm)	極數 Poles (P)	輸出功率 Output (W)	規格 Type	電壓 Voltage (V)	頻率 Frequency (Hz)	負荷 Duty (min)	額定 Rated Load				啟動電流 Starting Current (A)	啟動轉矩 Starting Torque (kgf·cm)	
							輸入功率 Input (W)	電流 Current (A)	轉速 Speed (RPM/min)	轉矩 Torque (kgf·cm)			
80	4	25	CM08RG25TB CM08RA25TB	220	50	30	54	0.24	1250	1.9	0.48	5.4	
				220	60	30	52	0.2	1500	1.6	0.46	4.3	
				230	50	30	56	0.25	1250	1.9	0.52	6.2	
				230	60	30	52	0.21	1500	1.6	0.49	4.8	
			CM08RG25TC CM08RA25TC	380	50	30	53	0.13	1250	1.9	0.27	5.4	
				380	60	30	49	0.11	1500	1.6	0.26	4.2	
				CM08RG25TJ CM08RA25TJ	220	50	30	54	0.24	1250	1.9	0.48	5.4
					220	60	30	49	0.2	1500	1.5	0.45	4.2
			230		50	30	56	0.24	1250	1.9	0.5	5.9	
			230		60	30	52	0.21	1500	1.6	0.47	4.6	
			380	50	30	52	0.13	1250	1.9	0.27	5.3		
				380	60	30	48	0.11	1500	1.5	0.26	4.1	

如馬達特性變更，恕不另行通知，以馬達銘牌為準。

In case of change of motor characteristics, no further notice shall be given. The information shown on the nameplate of motor is taken as standard.

馬達線圖 Motor

CM09 □ 40

註：IA (*) 為 IA 型相關尺寸

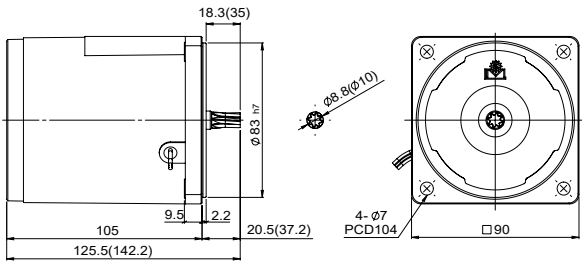

重量 Weight : 2.3kg ±5%

CM09 □ 40T

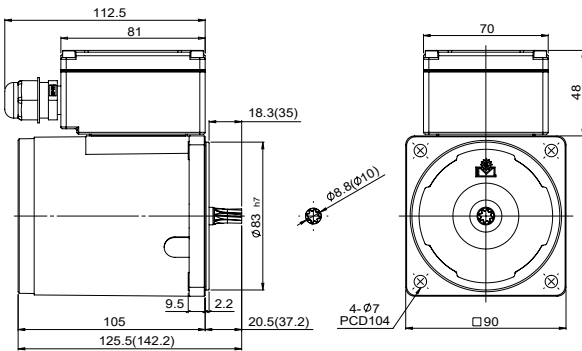

重量 Weight : 2.7kg ±5%

CM09 □ 40T1

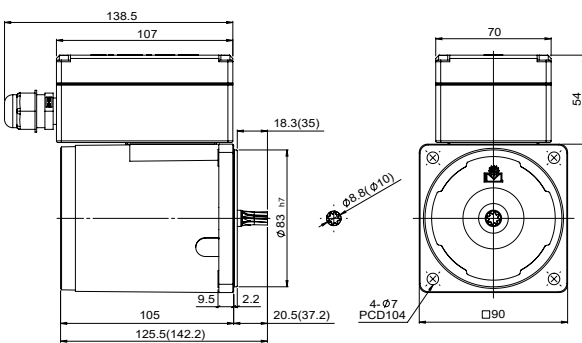

重量 Weight : 2.5kg ±5%

減速機線圖 Gear Head

CG09B □ S □

註：(*) 為 1/90~1/240 之尺寸

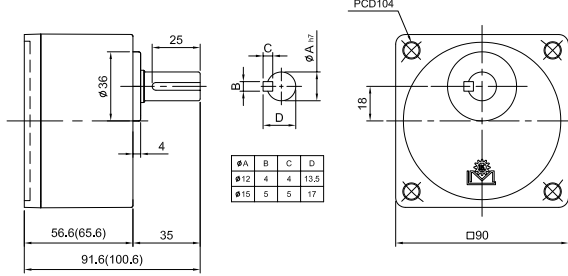

CG09B □ X

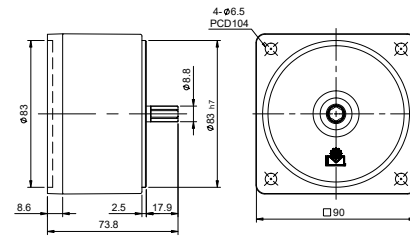

CGCU09B □ S □

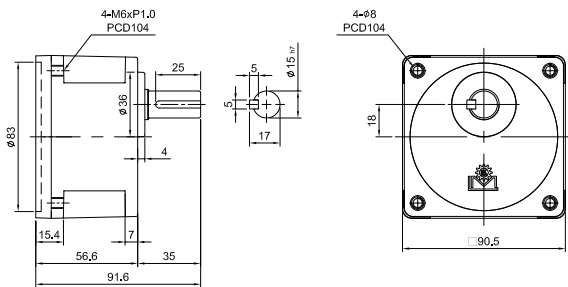

CGU09B □ S □

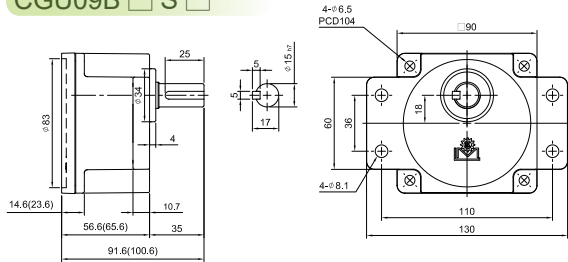

CGB09B □ H □

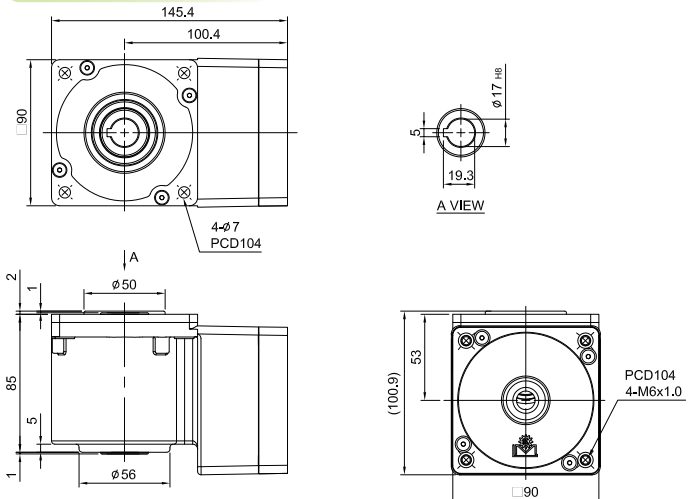

直接連結減速馬達時之容許轉矩 Permissible Torque of Direct Link Gearmotor

輸出功率 Output Power	馬達型號 Motor Model	減速機型號 Reducer Model	減速比 Ratio	轉速 Speed (RPM)		容許 Permissible (kgf·cm)		減速機出力軸旋轉方向 Rotating direction of output shaft of speed reducer
				50Hz	60Hz	50Hz	60Hz	
40W	CM09RG40	CG09 □	3	500	600	7.3	6.3	(A) 與馬達同一方向旋轉 Rotating in the same direction as the motor
			5	300	360	12	10	
			6	250	300	14.7	12	
			7.5	200	240	18	15	
			9	166	200	22	19	
			12.5	120	144	30	26	
			15	100	120	36	30	(B) 與馬達相反方向旋轉 Rotating in the opposite direction to the motor
			18	83	100	43	37	
			25	60	72	54	45	
			30	50	60	65	54	
			36	42	50	77	65	
			50	30	36	100	90	
			60	25	30	100	100	(C) 與馬達同一方向旋轉 Rotating in the same direction as the motor
			75	20	24	100	100	
			90	17	20	100	100	
			100	15	18	100	100	
			120	12.5	15	100	100	
			150	10	12	100	100	
180	8.3	10	100	100				
200	7.5	9	100	100				
240	6.25	7.5	100	100				

直接連結減速馬達時之容許轉矩 (中空軸) Permissible Torque of Direct Link Gearmotor (Hollow Output Shaft)

輸出功率 Output Power	馬達型號 Motor Model	減速機型號 Reducer Model	減速比 Ratio / 頻率 (Hz)	轉速 RPM															
				9	15	18	22.5	27	37.5	45	54	75	90	108	150	180			
40W	CM09RG40	CGB09 □	50Hz	轉速 RPM	166	100	83	66	55	40	33	27	20	16	13	10	8.3		
				容許 Nm	2	3.4	4	5.1	6.1	8.5	10.2	12.2	12.2	12.2	12.2	12.2	12.2	12.2	
			60Hz	轉速 RPM	200	120	100	80	66	48	40	33	24	20	16	12	10		
				容許 Nm	1.6	2.7	3.3	4.1	5	6.9	8.3	10	10	10	10	10	10	10	
減速機出力軸旋轉方向 Rotating direction of output shaft of speed reducer				(A) 與馬達相反方向旋轉 Rotating in the opposite direction to the motor								(B) 與馬達同一方向旋轉 Rotating in the same direction as the motor							

40W 可逆馬達規格表

框號尺寸 SIZE (mm)	極數 Poles (P)	輸出功率 Output (W)	規格 Type	電壓 Voltage (V)	頻率 Frequency (Hz)	負荷 Duty (min)	額定 Rated Load				啟動電流 Starting Current (A)	啟動轉矩 Starting Torque (kgf·cm)	
							輸入功率 Input (W)	電流 Current (A)	轉速 Speed (RPM/min)	轉矩 Torque (kgf·cm)			
90	4	40	CM09RG40TB CM09RA40TB	200	50	30	73	0.29	1300	2.95	0.76	7	
				200	60	30	71	0.26	1550	2.4	0.71	5.4	
				220	50	30	81	0.31	1300	3.2	0.84	8.8	
				220	60	30	74	0.27	1600	2.4	0.78	6.5	
				230	50	30	77	0.31	1350	3	0.89	9.8	
				230	60	30	72	0.27	1600	2.4	0.83	7.4	
			CM09RG40TC CM09RA40TC	380	50	30	75	0.17	1300	3	0.47	8.7	
				380	60	30	73	0.15	1600	2.4	0.44	6.5	
				CM09RG40TJ CM09RA40TJ	200	50	30	68	0.27	1250	3	0.72	7.1
					200	60	30	64	0.24	1550	2.4	0.67	5.4
					220	50	30	74	0.29	1300	3.2	0.8	8.8
					220	60	30	65	0.24	1600	2.4	0.75	6.7
				230	50	30	77	0.29	1300	3.5	0.8	8.8	
				230	60	30	70	0.25	1600	2.6	0.79	7.3	
380	50	30	77	0.17	1300	3.4	0.46	8.8					
380	60	30	65	0.14	1600	2.4	0.43	6.6					

如馬達特性變更，恕不另行通知，以馬達銘牌為準。

In case of change of motor characteristics, no further notice shall be given. The information shown on the nameplate of motor is taken as standard.

馬達線圖 Motor

CM09 □ 60F

註：IA (*) 為 IA 型相關尺寸

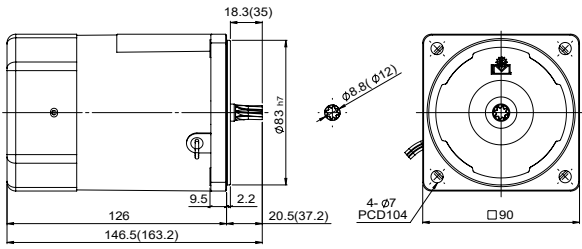

重量 Weight : 2.5kg ±5%

CM09 □ 60 □ FT

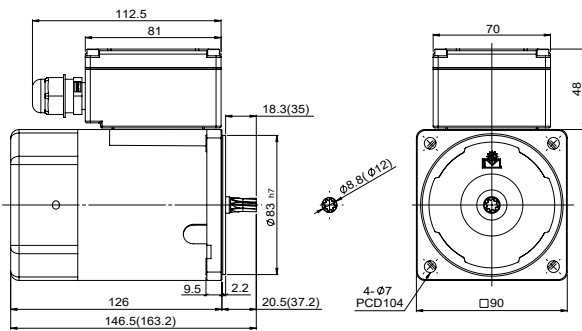

重量 Weight : 2.8kg ±5%

CM09 □ 60 □ FT1

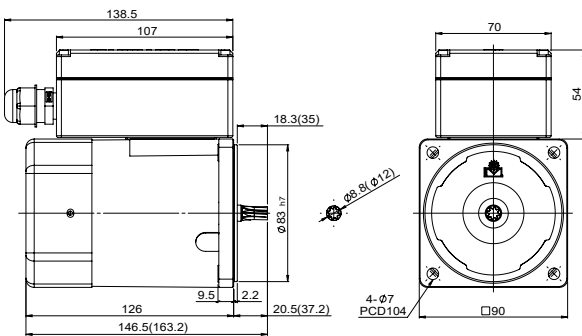

重量 Weight : 2.7kg ±5%

減速機線圖 Gear Head

CG09B □ S □

註：(*) 為 1/90~1/240 之尺寸

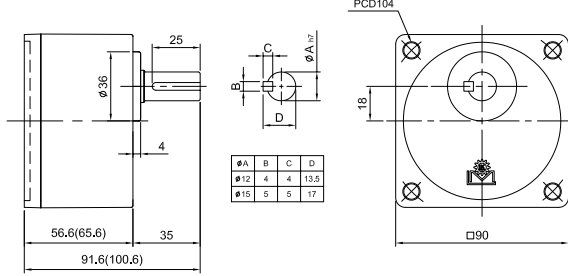

CG09B □ X

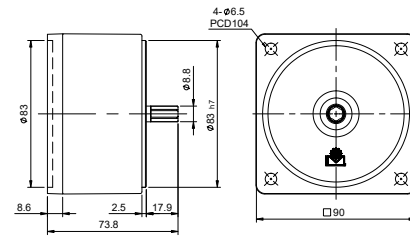

CGCU09B □ S □

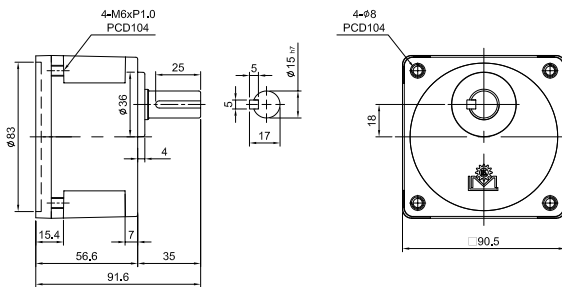

CGU09B □ S □

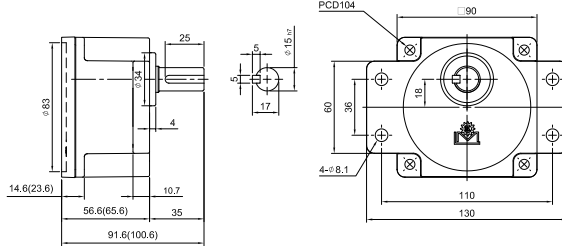

CGB09B □ H □

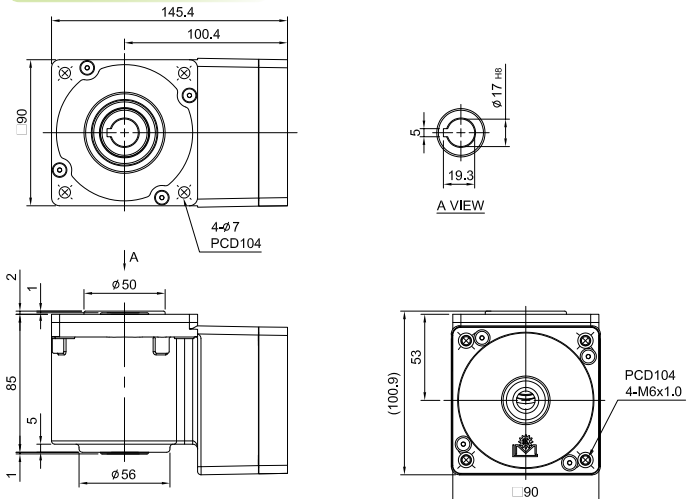

直接連結減速馬達時之容許轉矩 Permissible Torque of Direct Link Gearmotor

輸出功率 Output Power	馬達型號 Motor Model	減速機型號 Reducer Model	減速比 Ratio	轉速 Speed (RPM)		容許 Permissible (kgf·cm)		減速機出力軸旋轉方向 Rotating direction of output shaft of speed reducer
				50Hz	60Hz	50Hz	60Hz	
60W	CM09RG60	CG09 □	3	500	600	12	9.8	(A) 與馬達同一方向旋轉 Rotating in the same direction as the motor
			5	300	360	19	16	
			6	250	300	22	19	
			7.5	200	240	28	24	
			9	166	200	34	28	
			12.5	120	144	48	40	
			15	100	120	55	47	
			18	83	100	62	55	
			25	60	72	82	69	
			30	50	60	98	83	(B) 與馬達相反方向旋轉 Rotating in the opposite direction to the motor
			36	42	50	118	100	
			50	30	36	164	138	
			60	25	30	196	160	
			75	20	24	200	175	
			90	17	20	200	200	
			100	15	18	200	200	(C) 與馬達同一方向旋轉 Rotating in the same direction as the motor
			120	12.5	15	200	200	
			150	10	12	200	200	
180	8.3	10	200	200				
200	7.5	9	200	200				
240	6.25	7.5	200	200				

直接連結減速馬達時之容許轉矩 (中空軸) Permissible Torque of Direct Link Gearmotor (Hollow Output Shaft)

輸出功率 Output Power	馬達型號 Motor Model	減速機型號 Reducer Model	減速比 Ratio / 頻率 (Hz)	容許轉矩 (Nm)															
				9	15	18	22.5	27	37.5	45	54	75	90	108	150	180			
60W	CM09RG60	CGB09 □	50Hz	轉速 RPM	166	100	83	66	55	40	33	27	20	16	13	10	8.3		
				容許 Nm	3.2	5.4	6.5	8.2	9.8	13.6	16.4	19.6	19.6	19.6	19.6	19.6	19.6	19.6	
			60Hz	轉速 RPM	200	120	100	80	66	48	40	33	24	20	16	12	10		
				容許 Nm	2.6	4.3	5.2	6.5	7.8	10.9	13.1	15.7	15.7	15.7	15.7	15.7	15.7	15.7	
減速機出力軸旋轉方向 Rotating direction of output shaft of speed reducer				(A) 與馬達相反方向旋轉 Rotating in the opposite direction to the motor								(B) 與馬達同一方向旋轉 Rotating in the same direction as the motor							

60W 可逆馬達規格表

框號尺寸 SIZE (mm)	極數 Poles (P)	輸出功率 Output (W)	規格 Type	電壓 Voltage (V)	頻率 Frequency (Hz)	負荷 Duty (min)	額定 Rated Load				啟動電流 Starting Current (A)	啟動轉矩 Starting Torque (kgf·cm)	
							輸入功率 Input (W)	電流 Current (A)	轉速 Speed (RPM/min)	轉矩 Torque (kgf·cm)			
90	4	60	CM09RG60TBF CM09RA60TBF	200	50	30	102	0.43	1300	4.6	1.1	10.8	
				200	60	30	98	0.38	1550	3.7	1	8.3	
				220	50	30	107	0.45	1300	4.5	1.2	13.2	
				220	60	30	100	0.38	1600	3.7	1.1	10	
				230	50	30	107	0.46	1350	4.3	1.2	14.2	
				230	60	30	100	0.38	1600	3.6	1.2	10	
			CM09RG60TCF CM09RA60TCF	380	50	30	105	0.25	1300	4.4	0.7	13.2	
				380	60	30	98	0.21	1600	3.6	0.65	10	
				CM09RG60TJF CM09RA60TJF	200	50	30	107	0.43	1250	4.6	1	10.3
					200	60	30	106	0.39	1500	3.9	1	7.8
					220	50	30	118	0.46	1300	4.9	1.2	12.7
					220	60	30	99	0.37	1600	3.6	1.1	9.7
				230	50	30	109	0.47	1350	4.3	1.2	14	
				230	60	30	101	0.39	1600	3.6	1.2	10	
380	50	30	108	0.26	1300	4.5	0.71	12.9					
380	60	30	100	0.22	1600	3.6	0.65	9.7					

如馬達特性變更，恕不另行通知，以馬達銘牌為準。

In case of change of motor characteristics, no further notice shall be given. The information shown on the nameplate of motor is taken as standard.

馬達線圖 Motor

CM09 □ 90F

註：IA (*) 為 IA 型相關尺寸

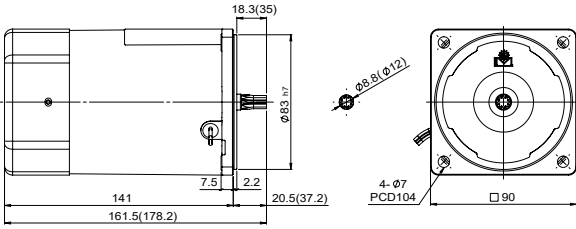

重量 Weight : 3.1kg ±5%

CM09 □ 90FT

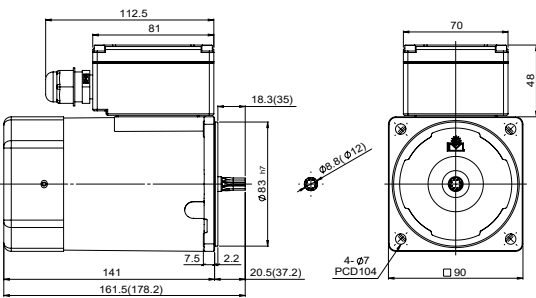

重量 Weight : 3.5kg ±5%

CM09 □ 90FT1

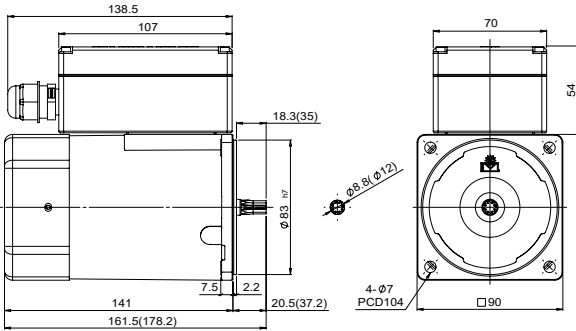

重量 Weight : 3.3kg ±5%

減速機線圖 Gear Head

CG09B □ S □

註：(*) 為 1/90~1/240 之尺寸

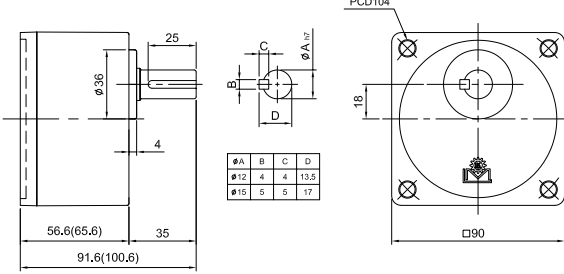

CG09B □ X

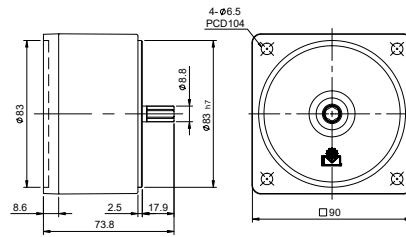

CGCU09B □ S □

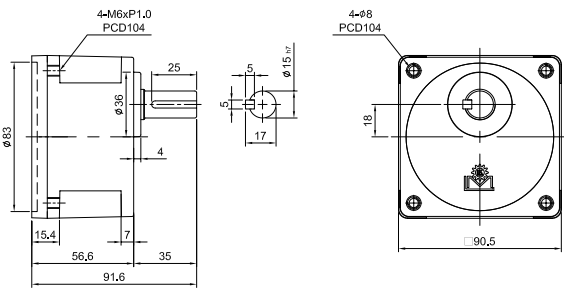

CGU09B □ S □

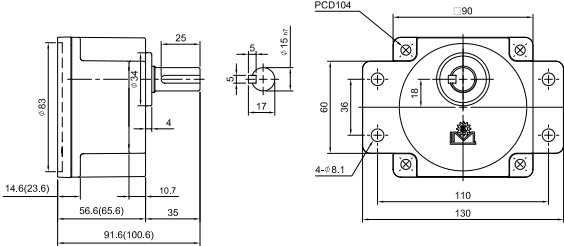

CGB09B □ H □

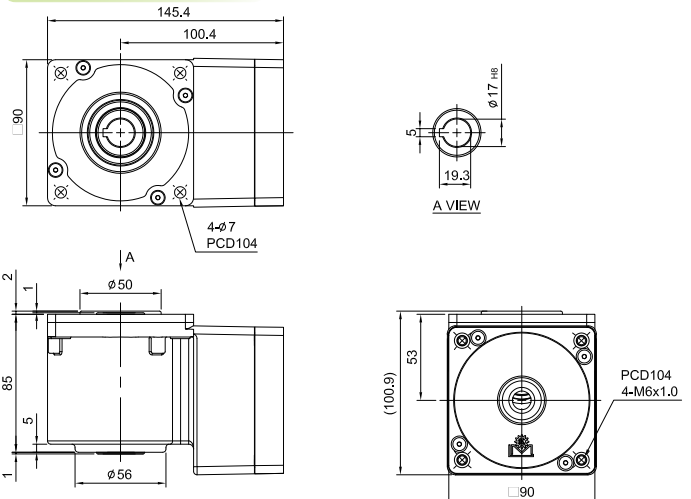

直接連結減速馬達時之容許轉矩 Permissible Torque of Direct Link Gearmotor

輸出功率 Output Power	馬達型號 Motor Model	減速機型號 Reducer Model	減速比 Ratio	轉速 Speed (RPM)		容許 Permissible (kgf·cm)		減速機出力軸旋轉方向 Rotating direction of output shaft of speed reducer
				50Hz	60Hz	50Hz	60Hz	
90W	CM09IG90	CG09 □	3	500	600	18	14	(A) 與馬達同一方向旋轉 Rotating in the same direction as the motor
			5	300	360	28	24	
			6	250	300	34	28	
			7.5	200	240	43	35	
			9	166	200	51	42	
			12.5	120	144	71	60	
			15	100	120	85	70	(B) 與馬達相反方向旋轉 Rotating in the opposite direction to the motor
			18	83	100	96	80	
			25	60	72	125	103	
			30	50	60	150	124	
			36	42	50	178	149	
			50	30	36	200	200	
			60	25	30	200	200	(C) 與馬達同一方向旋轉 Rotating in the same direction as the motor
			75	20	24	200	200	
			90	17	20	200	200	
			100	15	18	200	200	
			120	12.5	15	200	200	
			150	10	12	200	200	
180	8.3	10	200	200				
200	7.5	9	200	200				
240	6.25	7.5	200	200				

直接連結減速馬達時之容許轉矩 (中空軸) Permissible Torque of Direct Link Gearmotor (Hollow Output Shaft)

輸出功率 Output Power	馬達型號 Motor Model	減速機型號 Reducer Model	減速比 Ratio / 頻率 (Hz)	容許轉矩 (kgf·cm)															
				9	15	18	22.5	27	37.5	45	54	75	90	108	150	180			
90W	CM09RG90	CGB09 □	50Hz	轉速 RPM	166	100	83	66	55	40	33	27	20	16	13	10	8.3		
				容許 Nm	4.8	8	9.6	12	14.4	20	24	28.8	28.8	28.8	28.8	28.8	28.8	28.8	
			60Hz	轉速 RPM	200	120	100	80	66	48	40	33	24	20	16	12	10		
				容許 Nm	3.9	6.5	7.8	9.8	11.8	16.4	19.6	23.6	23.6	23.6	23.6	23.6	23.6	23.6	
減速機出力軸旋轉方向 Rotating direction of output shaft of speed reducer				(A) 與馬達相反方向旋轉 Rotating in the opposite direction to the motor								(B) 與馬達同一方向旋轉 Rotating in the same direction as the motor							

90W 可逆馬達規格表

框號尺寸 SIZE (mm)	極數 Poles (P)	輸出功率 Output (W)	規格 Type	電壓 Voltage (V)	頻率 Frequency (Hz)	負荷 Duty (min)	額定 Rated Load				啟動電流 Starting Current (A)	啟動轉矩 Starting Torque (kgf·cm)	
							輸入功率 Input (W)	電流 Current (A)	轉速 Speed (RPM/min)	轉矩 Torque (kgf·cm)			
90	4	90	CM09RG90TBF CM09RA90TBF	200	50	30	138	0.57	1300	6.7	1.79	19.3	
				200	60	30	135	0.51	1550	5.6	1.6	13.8	
				220	50	30	133	0.58	1350	6.4	1.96	22.3	
				220	60	30	132	0.5	1600	5.4	1.82	17.1	
				230	50	30	137	0.6	1350	6.4	2	22.2	
				230	60	30	139	0.5	1600	5.8	1.8	18.7	
			CM09RG90TCF CM09RA90TCF	380	50	30	148	0.37	1350	6.5	1.1	21.6	
				380	60	30	138	0.31	1600	5.5	1	15.9	
				CM09RG90TJF CM09RA90TJF	200	50	30	150	0.63	1300	6.6	1.7	16.6
					200	60	30	146	0.56	1550	5.6	1.6	12.5
					220	50	30	158	0.69	1350	6.6	1.9	20
					220	60	30	143	0.56	1600	5.4	1.7	15.3
					230	50	30	163	0.74	1350	6.4	2	22.6
					230	60	30	145	0.57	1600	5.4	1.9	17.5
380	50	30	154	0.39	1350	6.6	1.1	21.2					
380	60	30	143	0.32	1600	5.4	1	15.5					

如馬達特性變更，恕不另行通知，以馬達銘牌為準。

In case of change of motor characteristics, no further notice shall be given. The information shown on the nameplate of motor is taken as standard.

速度控制器 Speed Controller



Indication of Model Numbers

機種型號表示

組合型 Combined Style Speed Controller

SCU	SA	90W
機型 Type SCU : 標準型 Standard SCUN : 數字顯示型 Display Type SCUBL : 無刷驅動器 Brushless Driver	電壓 Voltage SA : 1Ø100V/120V SB : 1Ø200V/240V DA : DC24V DB : DC48V	功率識別 Power Identification 6W, 15W 25W, 40W 60W, 90W 100W, 200W 400W

分離型 Separated Style Speed Controller

SCS	SA	V	90W	EB
機型 Type SCS SCSBL	電壓 Voltage SA : 1Ø100V/120V SB : 1Ø200V/240V	功能 Function V : 旋鈕型	功率識別 Power Identification 6W, 15W 25W, 40W 60W, 90W	其他附件 Other Accessorles EB : 電磁式剎車 (11PIN 腳) 含調速功能 Electronic Brake (11PIN) VR EBA : 電磁式剎車 (8PIN 腳) 無調速功能 Electronic Brake (8PIN) non-VR

SCU 組合型控制器 SCU Assembly Type Controller

連接馬達與控制器的接頭，於控制器 AC 兩端接上 AC 電源 (請確認電源是否正確)，開關切到 RUN 的位置時 LED 為綠色，此時馬達為運轉狀態，調整控制器上的旋鈕即可控制馬達轉速快慢。註：SCUN 速度顯示組合型控制器使用方法與標準組合型控制器相同。

Connect motor and controller and supply AC power at power at AC two ends of controller AC power. (please check on correct power source). When the switch is turned to RUN position, LED is green. Then the motor is operating. Adjust the knob on the control to control the speed of the motor. Note: Operation of SCUN speed display controller is the same as standard assembly type control.

調速器外觀尺寸圖 Drawing of the Speed Controller

SCU-□

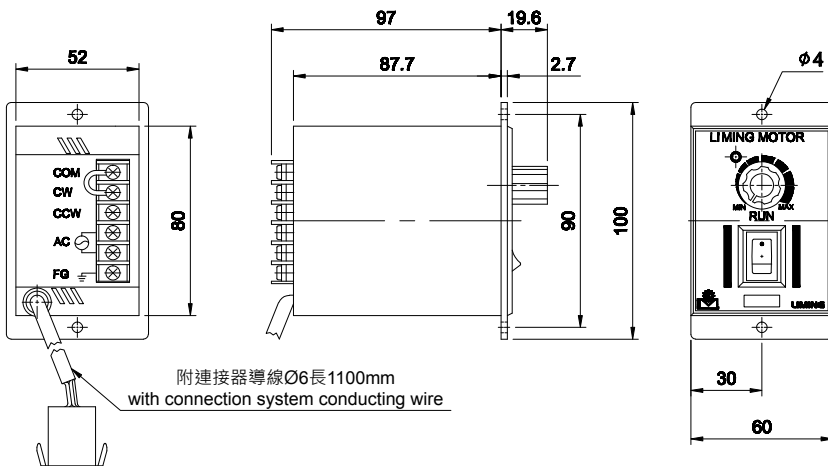

調速器面板安裝加工圖 Installation and Processing Diagram of Speed Control Panel

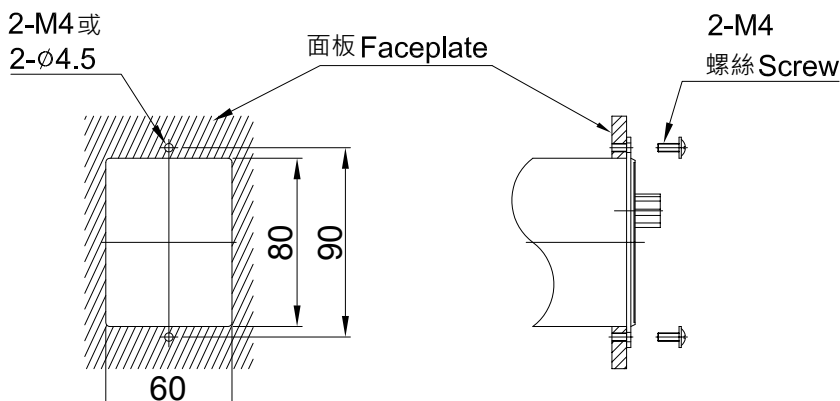

SCS 分離型控制器 SCS Separated Style Controller

分離型控制器一般是使用於配電盤內控制。控制器本體會有標示配線圖，於馬達與控制器腳座之間依配線圖配線完成後將控制器本體插入腳座，準備就緒後起動開關，調整旋鈕即可控制馬達轉速快慢。註：分離型控制器依功能區分會有 8 腳與 11 腳兩種控制器其安裝尺寸如下圖。

Separated type controller is generally used for control in an electric panel. The controller itself has marking of wiring diagram. After completion of wiring between motor base and control base, insert the controller main set into the base. When everything is ready, base please switch on the controller. Rotate the knob to control the speed of the motor. Note: According to the performance, separated style controller come with 8 pins and 11 pins. Installation of the two types of controls is shown below.

11 腳 .8 腳分離控制器外觀尺寸圖 11 Pins Exterior View of 8 Pins Separated Style Controller

◆ 11 腳 Pins

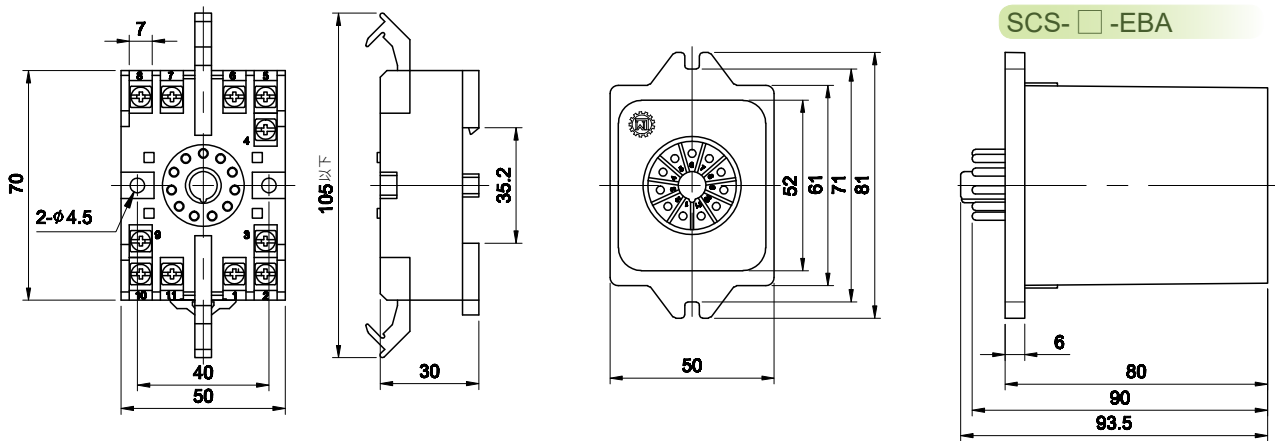

SCS-□ EBA

SCS-□

◆ 8 腳 Pins

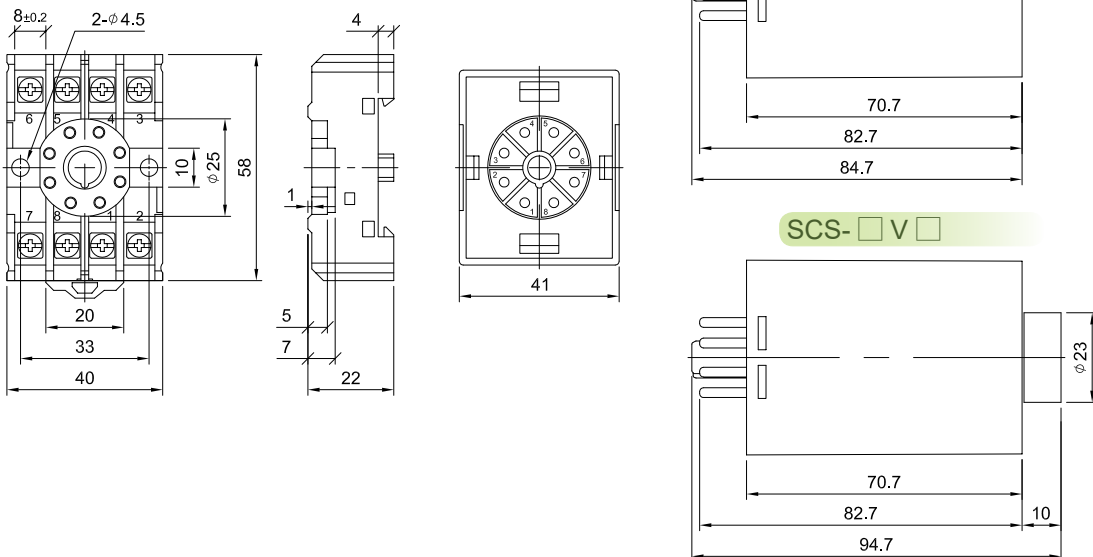

SCS-□ V □

SCS-SAEB · SCS-SBEB 外部配線圖 Wiring Diagram

◆正逆轉

CW / CCW Rotation

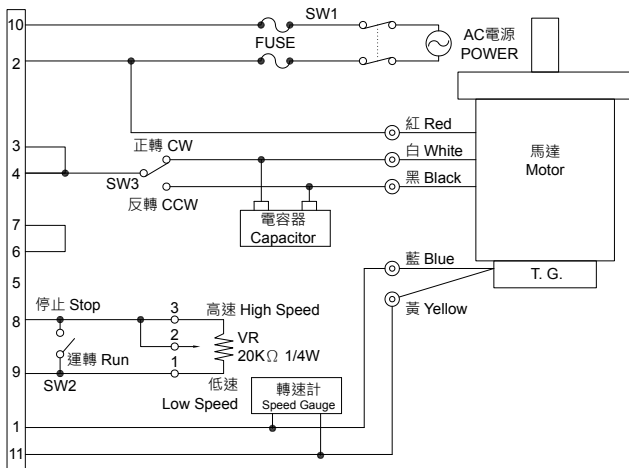

◆正逆轉附電磁剎車

CW / CCW Rotation with Electromagnetic Brake

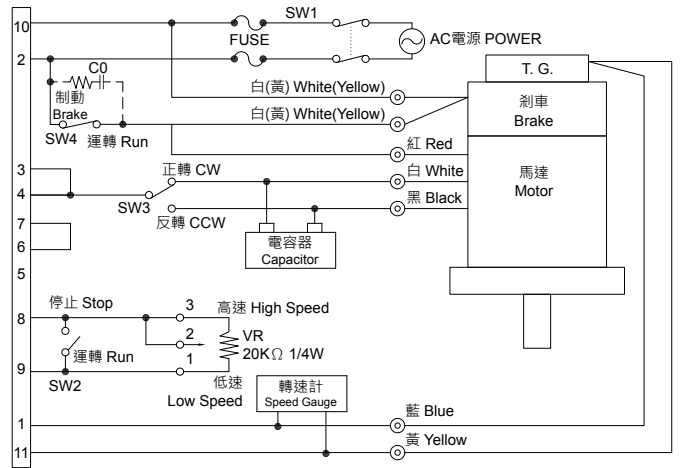

RoCo 為吸收突波用的 CR 迴路

CR Circuit to Absorb Surges

◆單一方向運轉附電子式剎車

One-way Rotation with Electronic Brake

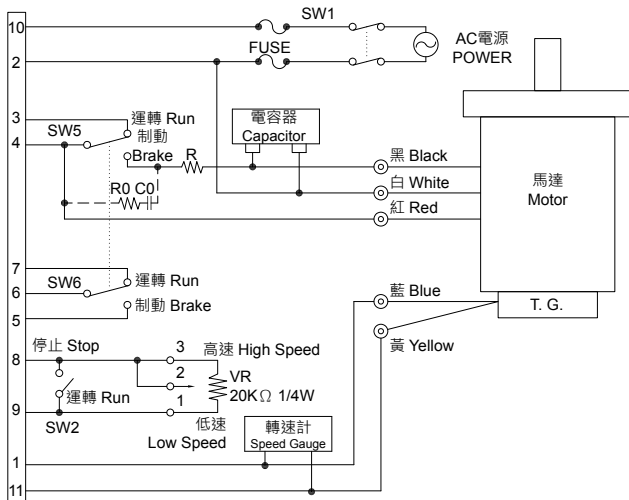

◆正逆轉附電子式剎車

CW / CCW with Electronic Brake

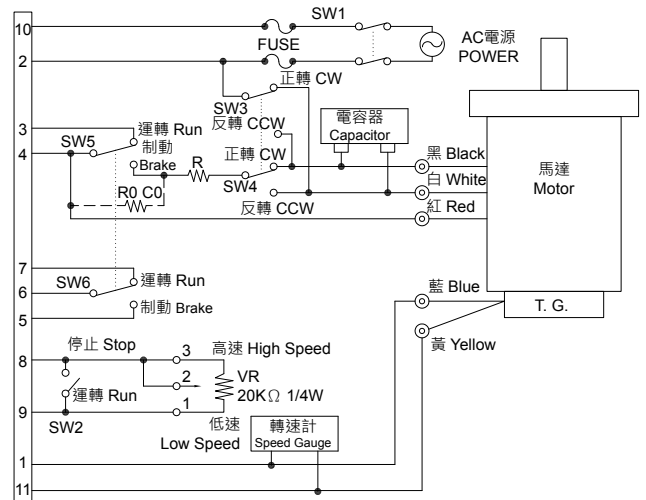

RoCo 為吸收突波用的 CR 迴路

CR Circuit to Absorb Surges

※ 突波吸收回路 (不提供)

Surge Absorbing CR Circuit.

(We don't provide this item.)

Ro=5-200Ω

Co=0.1-0.2 μf 200WV(400WV)

RoCo 為吸收突波用的 CR 迴路

CR Circuit to Absorb Surges

※ 突波吸收回路 (不提供)

Surge Absorbing CR Circuit.

(We don't provide this item.)

Ro=5-200Ω

Co=0.1-0.2 μf 200WV(400WV)

SCS-SA、SCS-SB 外部配線圖 Wiring Diagram

◆正逆轉附電磁剎車

CW / CCW Rotation Electromagnetic Brake

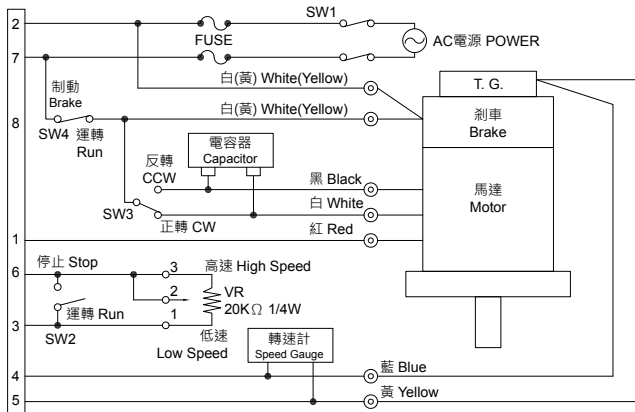

◆正逆轉

CW / CCW Rotation

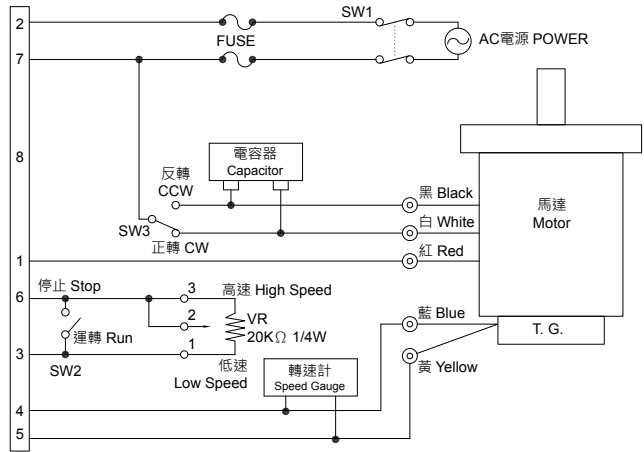

◆單一方向運轉

One-way Operation

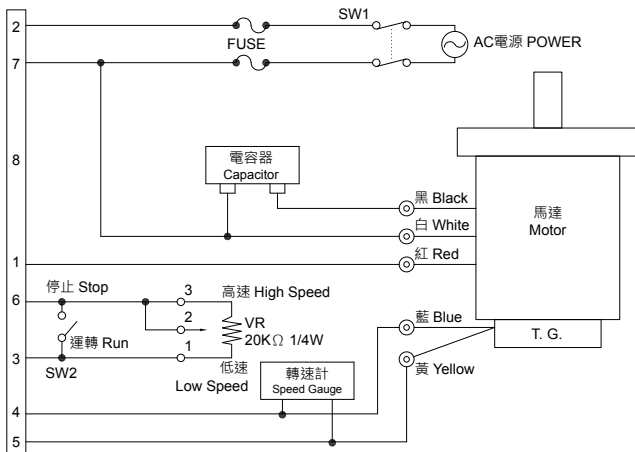

◆可變電阻外觀圖

Drawing of Variable Resistor

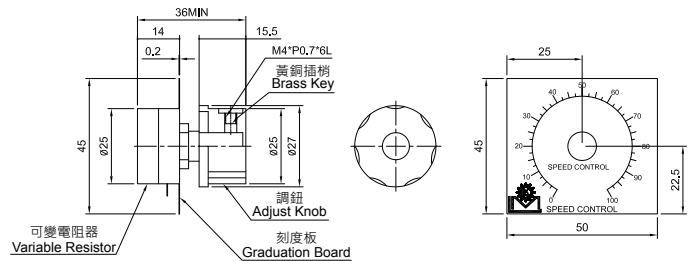

◆接線規格

Wiring Specification

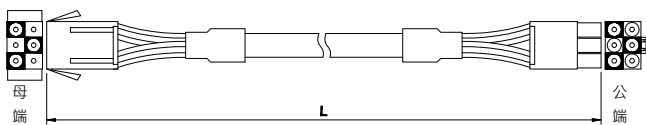

長度	料號
50	6EL-6C-AB50
100	6EL-6C-AB100
150	6EL-6C-AB150
200	6EL-6C-AB200

其他規格依客戶需求製作

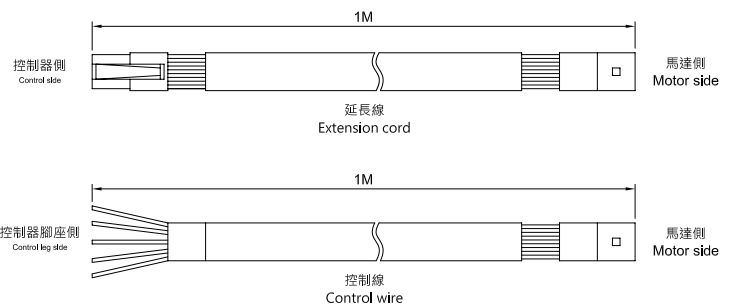

單相感應調速馬達

Single-Phase Induction Speed Variable Motor

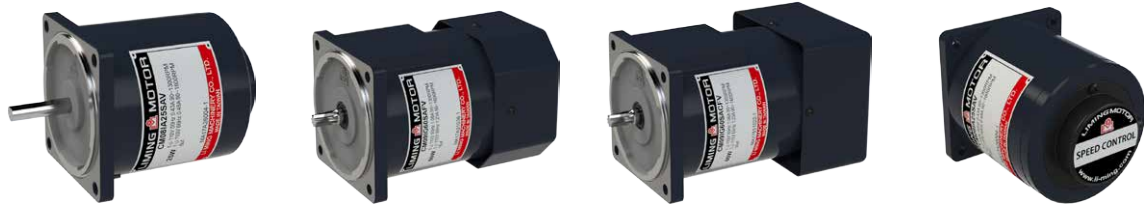

■ 單相感應調速馬達 Single-Phase Induction Speed Variable Motor

特徵：適用於單相馬達做速度調整控制。(50Hz: 90~14000rpm、60Hz: 90~1700rpm)
 (注：三相馬達做速度控制時一般則用變頻器控制)

Feature: Applicable for speed adjustment for single-phase motor
 (Note: The frequency converter is used for 3-phase motor, to control speed.)

■ 馬達一般規格 Motor General Specification

絕緣阻抗：在馬達的線圈與外殼間以 DC500V 高阻計測定，其數值在 100MΩ 以上。
 絕緣耐壓：在馬達的線圈與外殼間施加 50Hz 或 60Hz、1.5KV、1 分鐘無發生異常現象。
 溫度上升：於馬達額定運轉後以電阻法測定，溫度上升值在 80°C 以下。
 絕緣等級：B 種 (130°C)
 保護等級：導線型 IP20，端子盒型 IP54。
 使用溫度：-10°C ~+50°C (電容連續運轉馬達 -10°C ~+40°C) (不結凍狀態)。
 使用濕度：85% 以下 (不結露狀態)。
 強制風扇 (選配)：電壓 AC(110V,220V) 提供馬達低轉速時加強散熱。

Insulation impedance: Measure with DC500V high resistance gauge between the coil and casing of motor, the reading is 100M or higher.

Insulation resistance to pressure: Apply 50Hz or 60Hz, 1.5V between the coil and casing of motor for one minute without irregularity resulted.

Temperature rise: To specify by resistance method after motor reaches rated operation, temperature is less than 80°C .

Insulation: B (130°C)

Protection: Motor with conductive wire is IP20; motor with terminal box is IP54.

Operating temperature: -10°C ~+50°C (Capacitor operation motor -10°C ~+40°C) (No freezing)

Operating humidity: 85% or less (No condensation)

Electronic Fan (Optional): Voltage AC (110V, 220V) helps to dissipate heat at low motor speeds.

■ 感應調速馬達機構 Induction Speed Variable Motor Machinery

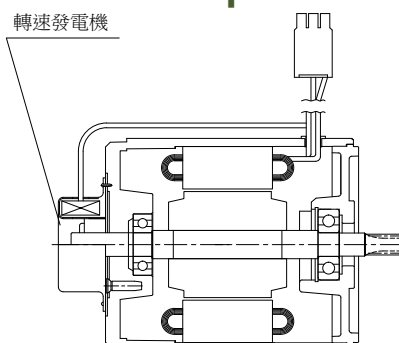

單相感應調速馬達 Single Phase Induction Speed Variable Motor

單相感應調速馬達

60 mm
6W

馬達線圖 Motor

CM06 □ 6V

註：IA (*) 為 IA 型相關尺寸

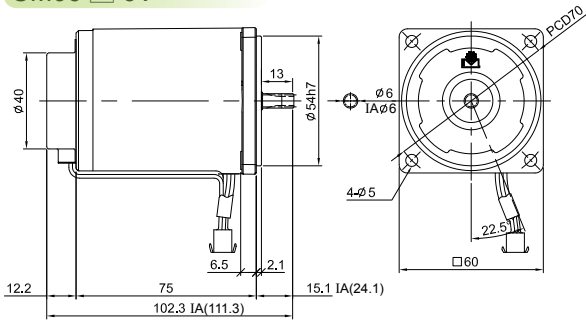

重量 Weight : 1kg ±5%

減速機線圖 Gear Head

CG06B □ S □

註：(*) 為 1/90~1/300 之尺寸

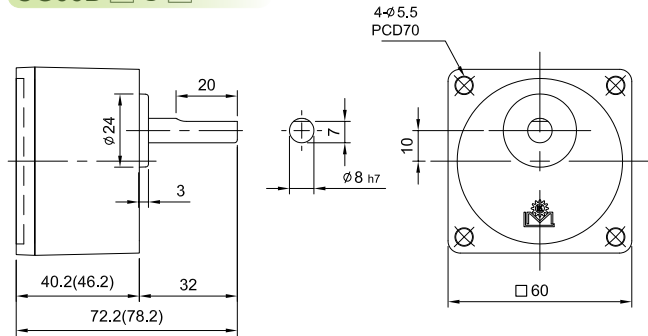

直接連結減速馬達時之容許轉矩 Permissible Torque of Direct Link Gearmotor

輸出功率 Output Power	馬達型號 Motor Model	減速機型號 Reducer Model	減速比 Ratio	轉速 Speed (RPM)		容許 Permissible (kgf-cm)		低速 Low Speed	減速機出力軸旋轉方向 Rotating direction of output shaft of speed reducer
				50Hz	60Hz	50Hz	60Hz		
6W	CM06IG06	CG06 □	3	500	600	1.2	1.0	30	(A) 與馬達同一方向旋轉 Rotating in the same direction as the motor
			5	300	360	1.9	1.5	18	
			6	250	300	2.3	1.8	15	
			7.5	200	240	2.9	2.3	12	
			9	166	200	3.4	2.8	10	
			12.5	120	144	4.7	3.9	7.2	
			15	100	120	5.7	4.7	6	(B) 與馬達相反方向旋轉 Rotating in the opposite direction to the motor
			18	83	100	6.8	5.6	5	
			25	60	72	9.3	7.0	3.6	
			30	50	60	11	8.3	3	
			36	42	50	13	10	2.5	
			50	30	36	16	13.8	1.8	
			60	25	30	20	16	1.5	(C) 與馬達同一方向旋轉 Rotating in the same direction as the motor
			75	20	24	24	20	1.2	
			90	17	20	30	24	1	
			100	15	18	30	30	0.9	
			120	12.5	15	30	30	0.75	
			150	10	12	30	30	0.6	
180	8.3	10	30	30	0.5				
200	7.5	9	30	30	-				
240	6.25	7.5	30	30	-				
300	5	6	30	30	-				

6W 調速馬達規格表

框號尺寸 SIZE (mm)	極數 Poles (P)	輸出功率 Output (W)	規格 Type	電壓 Voltage (V)	頻率 Frequency (Hz)	負荷 Duty (min)	額定 Rated Load				電容器 Capacitor (μ f / V)	啟動電流 Starting Current (A)	啟動轉矩 Starting Torque (kgf-cm)
							輸入功率 Input (W)	電流 Current (A)	轉速 Speed (RPM/min)	轉矩 Torque (kgf-cm)			
60	4	6	CM06IG6SAV CM06IA9SAV	100	50	CONT.	29	0.3	90	0.41	2.5 / 250	0.3	0.3
							20	0.22	1300	0.42			
				100	60	CONT.	28	0.3	90	0.4	2.5 / 250	0.29	0.33
							18	0.19	1600	0.4			
			110	50	CONT.	35	0.32	90	0.46	2.5 / 250	0.32	0.4	
						24	0.24	1300	0.49				
			110	60	CONT.	34	0.32	90	0.47	2.5 / 250	0.32	0.4	
						22	0.21	1600	0.47				
			CM06IG6SBV CM06IA6SBV	220	50	CONT.	29	0.13	90	0.77	0.8 / 450	0.13	0.69
							21	0.1	1300	0.49			
				220	60	CONT.	31	0.14	90	0.76	0.8 / 450	0.14	0.72
							25	0.11	1600	0.43			
230	50	CONT.		31	0.11	90	0.84	0.8 / 450	0.14	0.76			
				23	0.1	1300	0.53						
230	60	CONT.		34	0.15	90	0.85	0.8 / 450	0.15	0.84			
				28	0.12	1600	0.45						
240	50	CONT.	34	0.14	90	0.9	0.8 / 450	0.14	0.83				
			25	0.1	1300	0.57							
240	60	CONT.	37	0.15	90	0.93	0.8 / 450	0.15	0.85				
			34	0.12	1600	0.49							

如馬達特性變更，恕不另行通知，以馬達銘牌為準。

In case of change of motor characteristics, no further notice shall be given. The information shown on the nameplate of motor is taken as standard.

馬達線圖 Motor

CM07 □ 15V

註：IA (*) 為 IA 型相關尺寸

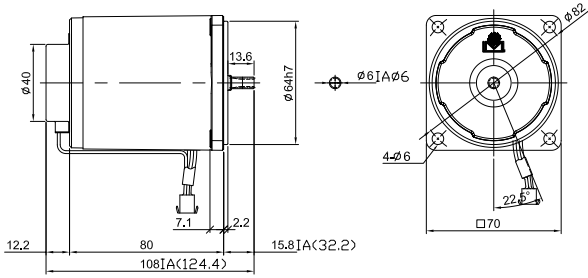

減速機線圖 Gear Head

CG07B □ S □

註：(*) 為 1/90~1/240 之尺寸

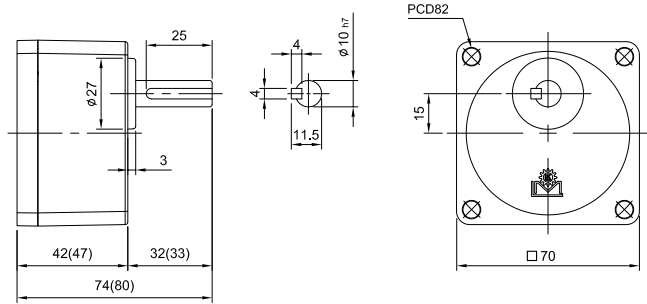

重量 Weight : 1.4kg ±5%

直接連結減速馬達時之容許轉矩 Permissible Torque of Direct Link Gearmotor

輸出功率 Output Power	馬達型號 Motor Model	減速機型號 Reducer Model	減速比 Ratio	轉速 Speed (RPM)		容許 Permissible (kgf-cm)		低速 Low Speed	減速機出力軸旋轉方向 Rotating direction of output shaft of speed reducer
				50Hz	60Hz	50Hz	60Hz		
15W	CM07IG15	CG07 □	3	500	600	3.0	2.6	30	(A) 與馬達同一方向旋轉 Rotating in the same direction as the motor
			5	300	360	4.7	3.9	18	
			6	250	300	5.7	4.7	15	
			7.5	200	240	7.1	5.8	12	
			9	166	200	8.5	7.0	10	
			12.5	120	144	11.8	9.8	7.2	
			15	100	120	14.2	11.8	6	(B) 與馬達相反方向旋轉 Rotating in the opposite direction to the motor
			18	83	100	18	15	5	
			25	60	72	23	19	3.6	
			30	50	60	28	23	3	
			36	42	50	33	27.6	2.5	
			50	30	36	46	38.4	1.8	
			60	25	30	50	46	1.5	(C) 與馬達同一方向旋轉 Rotating in the same direction as the motor
			75	20	24	50	50	1.2	
			90	17	20	50	50	1	
			100	15	18	50	50	0.9	
			120	12.5	15	50	50	0.75	
			150	10	12	50	50	0.6	
			180	8.3	10	50	50	0.5	
			200	7.5	9	50	-	-	
			240	6.25	7.5	50	-	-	
			300	5	6	-	-	-	

15W 調速馬達規格表

框號尺寸 SIZE (mm)	極數 Poles (P)	輸出功率 Output (W)	規格 Type	電壓 Voltage (V)	頻率 Frequency (Hz)	負荷 Duty (min)	額定 Rated Load				電容器 Capacitor (μf/V)	啟動電流 Starting Current (A)	啟動轉矩 Starting Torque (kgf-cm)
							輸入功率 Input (W)	電流 Current (A)	轉速 Speed (RPM/min)	轉矩 Torque (kgf-cm)			
70	4	15	CM07IG15SAV CM07IA15SAV	100	50	CONT.	55	0.59	90	0.93	5 / 250	0.59	0.93
							34	0.37	1250	1.1			
				100	60	CONT.	52	0.55	90	0.89	5 / 250	0.55	0.89
							31	0.31	1600	0.91			
				110	50	CONT.	68	0.66	90	0.11	5 / 250	0.66	1.1
							39	0.4	1300	1.1			
			110	60	CONT.	64	0.61	90	1.1	5 / 250	0.61	1.1	
						37	0.34	1600	1				
			CM07IG15SBV CM07IA15SBV	220	50	CONT.	74	0.37	90	0.9	1 / 450	0.36	0.89
							45	0.24	1250	1.1			
				220	60	CONT.	68	0.33	90	0.9	1 / 450	0.33	0.87
							36	0.18	1600	1			
230	50	CONT.		81	0.38	90	1	1 / 450	0.38	0.95			
				48	0.26	1300	1						
230	60	CONT.	75	0.35	90	1	1 / 450	0.35	0.95				
			39	0.19	1600	1							
240	50	CONT.	89	0.4	90	1	1 / 450	0.4	1				
			52	0.27	1300	1							
240	60	CONT.	82	0.37	90	1	1 / 450	0.37	1				
			43	0.21	1600	1							

如馬達特性變更，恕不另行通知，以馬達銘牌為準。

In case of change of motor characteristics, no further notice shall be given. The information shown on the nameplate of motor is taken as standard.

馬達線圖 Motor

CM08 □ 25V

註：IA (*) 為 IA 型相關尺寸

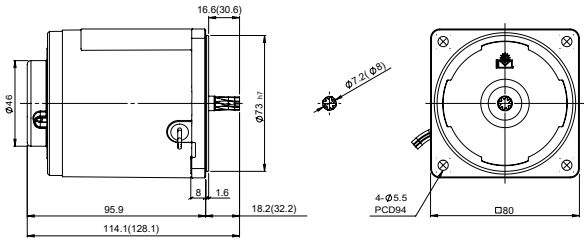

重量 Weight : 1.5kg ±5%

減速機線圖 Gear Head

CG08B □ S □

註：(*) 為 1/90~1/300 之尺寸

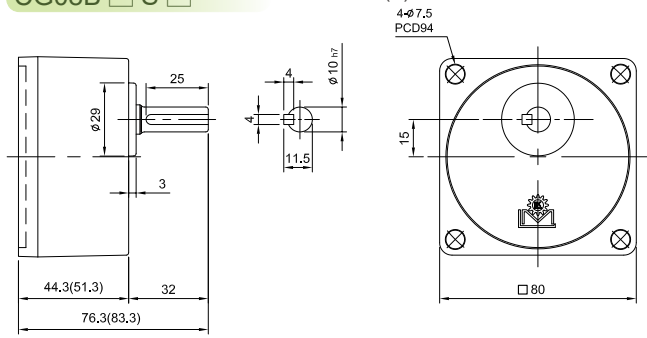

CG08B □ X

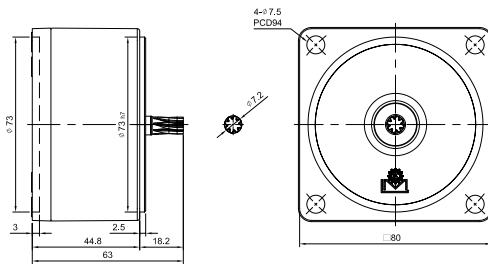

直接連結減速馬達時之容許轉矩 Permissible Torque of Direct Link Gearmotor

輸出功率 Output Power	馬達型號 Motor Model	減速機型號 Reducer Model	減速比 Ratio	轉速 Speed (RPM)		容許 Permissible (kgf·cm)		低速 Low Speed	減速機出力軸旋轉方向 Rotating direction of output shaft of speed reducer
				50Hz	60Hz	50Hz	60Hz		
25W	CM08IG25	CG08 □	3	500	600	5.0	4.1	30	(A) 與馬達同一方向旋轉 Rotating in the same direction as the motor
			5	300	360	7.8	6.3	18	
			6	250	300	9.4	7.6	15	
			7.5	200	240	11.8	9.5	12	
			9	166	200	14.1	11.4	10	
			12.5	120	144	19.6	16	7.2	
			15	100	120	23	19	6	
			18	83	100	28	23	5	
			25	60	72	38	31	3.6	(B) 與馬達相反方向旋轉 Rotating in the opposite direction to the motor
			30	50	60	46	37	3	
			36	42	50	55	45	2.5	
			50	30	36	76	62	1.8	
			60	25	30	80	75	1.5	
			75	20	24	80	80	1.2	
			90	17	20	80	80	1	(C) 與馬達同一方向旋轉 Rotating in the same direction as the motor
			100	15	18	80	80	0.9	
			120	12.5	15	80	80	0.75	
			150	10	12	80	80	0.6	
			180	8.3	10	80	80	0.5	
			200	7.5	9	80	80	-	
240	6.25	7.5	80	80	-				
300	5	6	80	80	-				

25W 調速馬達規格表

框號尺寸 SIZE (mm)	極數 Poles (P)	輸出功率 Output (W)	規格 Type	電壓 Voltage (V)	頻率 Frequency (Hz)	負荷 Duty (min)	額定 Rated Load				電容器 Capacitor (μf/V)	啟動電流 Starting Current (A)	啟動轉矩 Starting Torque (kgf·cm)
							輸入功率 Input (W)	電流 Current (A)	轉速 Speed (RPM/min)	轉矩 Torque (kgf·cm)			
80	4	25	CM08IG25SAV CM08IA25SAV	100	50	CONT.	99	0.89	90	1.4	6 / 250	0.89	1.1
							46	0.5	1250	1.9			
				100	60	CONT.	99	0.84	90	1.3	6 / 250	0.84	1.1
							41	0.42	1550	1.5			
				110	50	CONT.	104	1	90	1.6	6 / 250	1	1.4
							49	0.5	1300	1.9			
			110	60	CONT.	99	0.9	90	1.6	6 / 250	0.9	1.5	
						43	0.4	1640	1.4				
			120	50	CONT.	125	1	90	1.9	6 / 250	1	1.7	
						55	0.5	1350	1.8				
			120	60	CONT.	119	1	90	1.9	6 / 250	1	1.6	
						49	0.42	1650	1.4				
			CM08IG25SBV CM08IA25SBV	220	50	CONT.	100	0.46	90	1.6	1.5 / 450	0.46	1.5
							50	0.25	1300	1.8			
				220	60	CONT.	97	0.46	90	1.5	1.5 / 450	0.46	1.4
							45	0.21	1600	1.5			
				230	50	CONT.	100	0.46	90	1.6	1.5 / 450	0.46	1.5
							53	0.26	1300	1.9			
230	60	CONT.	96	0.43	90	1.7	1.5 / 450	0.43	1.6				
			47	0.21	1600	1.5							
240	50	CONT.	109	0.48	90	2	1.5 / 450	0.48	1.6				
			26	0.26	1300	1.8							
240	60	CONT.	105	0.45	90	1.9	1.5 / 450	0.46	1.6				
			49	0.21	1600	1.5							

如馬達特性變更，恕不另行通知，以馬達銘牌為準。

In case of change of motor characteristics, no further notice shall be given. The information shown on the nameplate of motor is taken as standard.

馬達線圖 Motor

CM09 □ 40V

註：IA (*) 為 IA 型相關尺寸

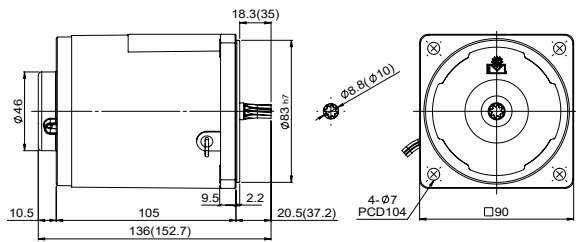

重量 Weight : 2.3kg ±5%

CM09 □ 40CFV

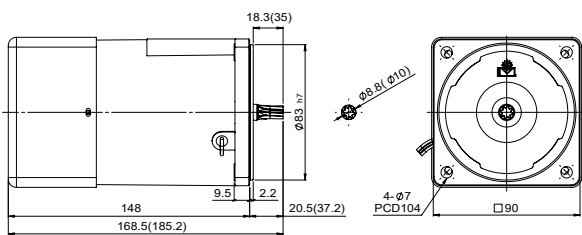

重量 Weight : 2.8kg ±5%

減速機線圖 Gear Head

CG09B □ S □

註：(*) 為 1/90~1/240 之尺寸

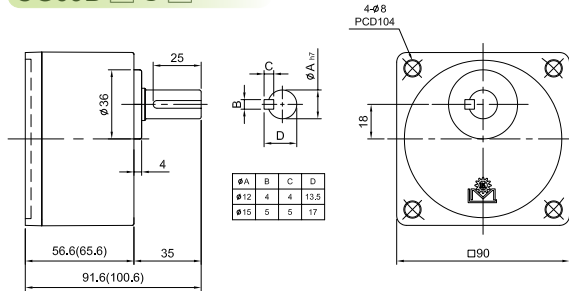

CG09B □ X

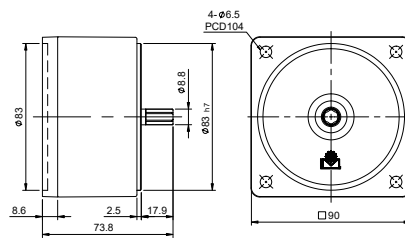

CGCU09B □ S □

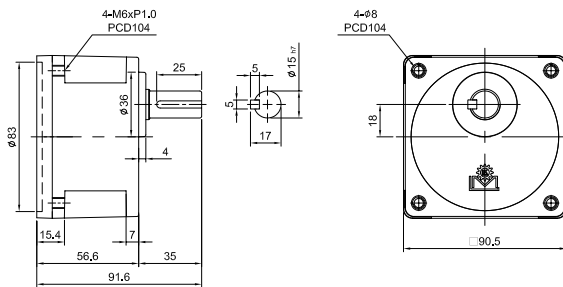

CGU09B □ S □

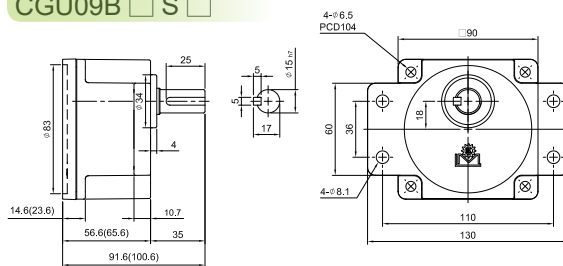

CGB09B □ H □

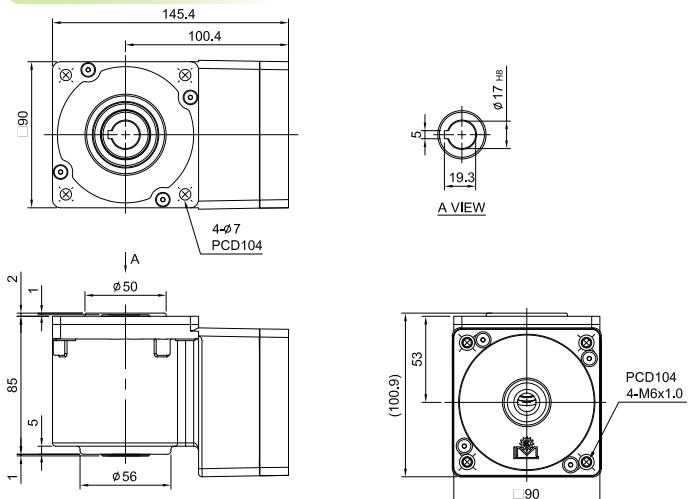

直接連結減速馬達時之容許轉矩 Permissible Torque of Direct Link Gearmotor

輸出功率 Output Power	馬達型號 Motor Model	減速機型號 Reducer Model	減速比 Ratio	轉速 Speed (RPM)		容許 Permissible (kgf-cm)		低速 Low Speed	減速機出力軸旋轉方向 Rotating direction of output shaft of speed reducer
				50Hz	60Hz	50Hz	60Hz		
40W	CM09IG40	CG09 □	3	500	600	7.3	6.3	30	(A) 與馬達同一方向旋轉 Rotating in the same direction as the motor
			5	300	360	12	10	18	
			6	250	300	14.7	12	15	
			7.5	200	240	18	15	12	
			9	166	200	22	19	10	
			12.5	120	144	30	26	7.2	
			15	100	120	36	30	6	(B) 與馬達相反方向旋轉 Rotating in the opposite direction to the motor
			18	83	100	43	37	5	
			25	60	72	54	45	3.6	
			30	50	60	65	54	3	
			36	42	50	77	65	2.5	
			50	30	36	100	90	1.8	
			60	25	30	100	100	1.5	(C) 與馬達同一方向旋轉 Rotating in the same direction as the motor
			75	20	24	100	100	1.2	
			90	17	20	100	100	1	
			100	15	18	100	100	0.9	
			120	12.5	15	100	100	0.75	
			150	10	12	100	100	0.6	
180	8.3	10	100	100	0.5				
200	7.5	9	100	100	-				
			240	6.25	7.5	100	100	-	

直接連結減速馬達時之容許轉矩 (中空軸) Permissible Torque of Direct Link Gearmotor (Hollow Output Shaft)

輸出功率 Output Power	馬達型號 Motor Model	減速機型號 Reducer Model	減速比 Ratio / 頻率 (Hz)	9	15	18	22.5	27	37.5	45	54	75	90	108	150	180	
				40W	CM09IG40	CGB09 □	50Hz	轉速 RPM 容許 Nm	166 2.4	100 4.1	83 4.9	66 6.1	55 7.4	40 10.3	33 12.3	27 14.8	20 14.8
			60Hz	轉速 RPM 容許 Nm	200 2.3	120 3.8	100 4.6	80 5.8	66 6.9	48 9.7	40 11.6	33 13.9	24 13.9	20 13.9	16 13.9	12 13.9	10 13.9
減速機出力軸旋轉方向 Rotating direction of output shaft of speed reducer				(A) 與馬達相反方向旋轉 Rotating in the opposite direction to the motor									(B) 與馬達同一方向旋轉 Rotating in the same direction as the motor				

40W 調速馬達規格表

框號尺寸 SIZE (mm)	極數 Poles (P)	輸出功率 Output (W)	規格 Type	電壓 Voltage (V)	頻率 Frequency (Hz)	負荷 Duty (min)	額定 Rated Load				電容器 Capacitor (μf/V)	啟動電流 Starting Current (A)	啟動轉矩 Starting Torque (kgf-cm)
							輸入功率 Input (W)	電流 Current (A)	轉速 Speed (RPM/min)	轉矩 Torque (kgf-cm)			
90	4	40	CM09IG40SAV CM09IA40SAV	100	50	CONT.	168	1.8	90	2.1	10 / 250	1.9	1.8
							77	0.83	1350	3.2			
				100	60	CONT.	100	1.6	90	2	10 / 250	1.7	1.8
							99	0.65	1650	2.3			
				110	50	CONT.	204	1.97	90	2.7	10 / 250	2	2.1
							87	0.88	1350	3.4			
			110	60	CONT.	190	1.83	90	2.5	10 / 250	1.84	2.3	
						86	0.79	1650	3.2				
			CM09IG40SBV CM09IA40SBV	220	50	CONT.	124	0.58	90	2.7	2.5 / 450	0.58	2.6
							72	0.32	1300	3			
				220	60	CONT.	120	0.55	90	2.6	2.5 / 450	0.55	2.6
							78	0.37	1600	2.5			
				230	50	CONT.	73	0.32	90	3	2.5 / 450	0.6	2.6
							74	0.32	1300	3			
230	60	CONT.		132	0.58	90	2.8	2.5 / 450	0.58	2.8			
				82	0.38	1600	2.5						
240	50	CONT.	146	0.62	90	3	2.5 / 450	0.63	2.8				
			72	0.3	1350	2.9							
240	60	CONT.	143	0.6	90	3	2.5 / 450	0.6	2.8				
			83	0.37	1650	2.3							

如馬達特性變更，恕不另行通知，以馬達銘牌為準。

In case of change of motor characteristics, no further notice shall be given. The information shown on the nameplate of motor is taken as standard.

馬達線圖 Motor

CM09 □ 60FV

註：IA (*) 為 IA 型相關尺寸

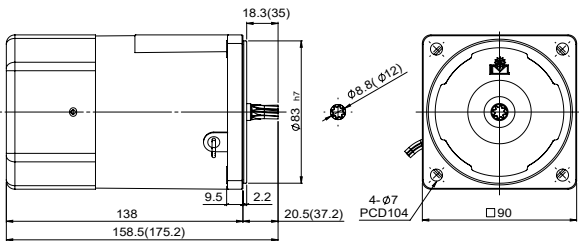

重量 Weight : 2.5kg ±5%

CM09 □ 60CFV

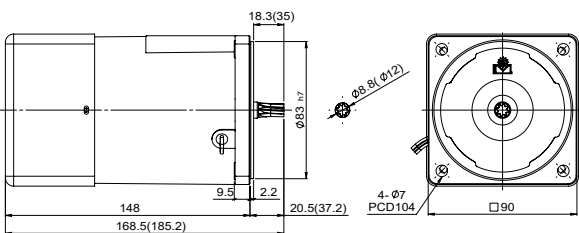

重量 Weight : 2.8kg ±5%

減速機線圖 Gear Head

CG09B □ S □

註：(*) 為 1/90~1/240 之尺寸

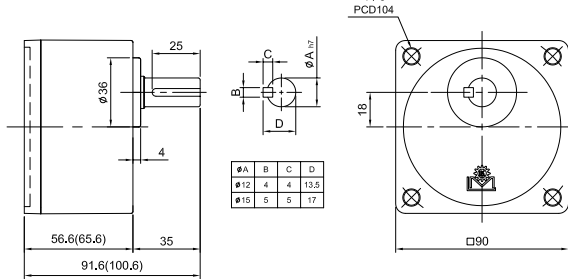

CG09B □ X

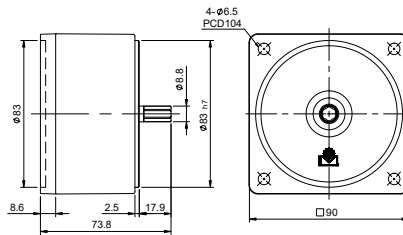

CGCU09B □ S □

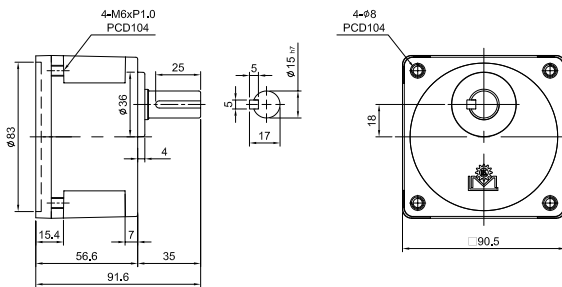

CGU09B □ S □

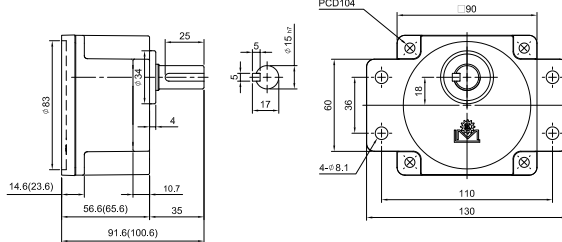

CGB09B □ H □

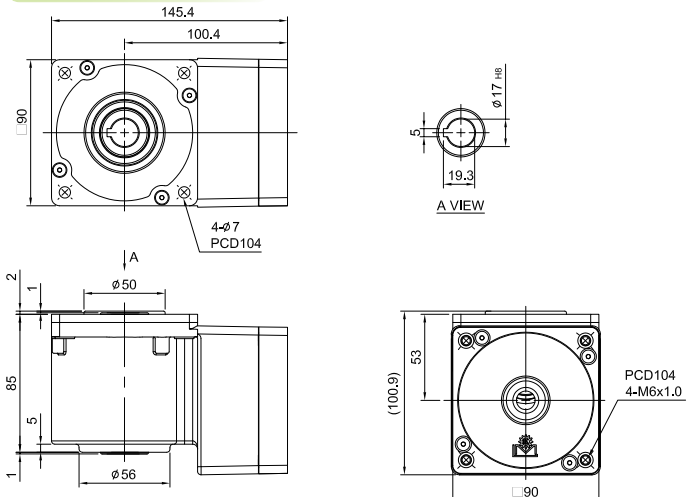

直接連結減速馬達時之容許轉矩 Permissible Torque of Direct Link Gearmotor

輸出功率 Output Power	馬達型號 Motor Model	減速機型號 Reducer Model	減速比 Ratio	轉速 Speed (RPM)		容許 Permissible (kgf-cm)		低速 Low Speed	減速機出力軸旋轉方向 Rotating direction of output shaft of speed reducer
				50Hz	60Hz	50Hz	60Hz		
60W	CM09IG60	CG09 □	3	500	600	12	9.8	30	(A) 與馬達同一方向旋轉 Rotating in the same direction as the motor
			5	300	360	19	16	18	
			6	250	300	22	19	15	
			7.5	200	240	28	24	12	
			9	166	200	34	28	10	
			12.5	120	144	48	40	7.2	
			15	100	120	55	47	6	(B) 與馬達相反方向旋轉 Rotating in the opposite direction to the motor
			18	83	100	62	55	5	
			25	60	72	82	69	3.6	
			30	50	60	98	83	3	
			36	42	50	118	100	2.5	
			50	30	36	164	138	1.8	
			60	25	30	196	160	1.5	(C) 與馬達同一方向旋轉 Rotating in the same direction as the motor
			75	20	24	200	175	1.2	
			90	17	20	200	200	1	
			100	15	18	200	200	0.9	
			120	12.5	15	200	200	0.75	
			150	10	12	200	200	0.6	
180	8.3	10	200	200	0.5				
200	7.5	9	200	200	-				
			240	6.25	7.5	200	200	-	

直接連結減速馬達時之容許轉矩 (中空軸) Permissible Torque of Direct Link Gearmotor (Hollow Output Shaft)

輸出功率 Output Power	馬達型號 Motor Model	減速機型號 Reducer Model	減速比 Ratio / 頻率 (Hz)	9	15	18	22.5	27	37.5	45	54	75	90	108	150	180	
				60W	CM09IG60	CGB09 □	50Hz	轉速 RPM 容許 Nm	166 3.3	100 5.5	83 6.7	66 8.3	55 10	40 13.9	33 16.7	27 20	20 20
			60Hz	轉速 RPM 容許 Nm	200 2.6	120 4.4	100 5.3	80 6.7	66 8	48 11.2	40 13.4	33 16.1	24 16.1	20 16.1	16 16.1	12 16.1	10 16.1
減速機出力軸旋轉方向 Rotating direction of output shaft of speed reducer				(A) 與馬達相反方向旋轉 Rotating in the opposite direction to the motor									(B) 與馬達同一方向旋轉 Rotating in the same direction as the motor				

60W 調速馬達規格表

框號尺寸 SIZE (mm)	極數 Poles (P)	輸出功率 Output (W)	規格 Type	電壓 Voltage (V)	頻率 Frequency (Hz)	負荷 Duty (min)	額定 Rated Load				電容器 Capacitor (μf/V)	啟動電流 Starting Current (A)	啟動轉矩 Starting Torque (kgf-cm)
							輸入功率 Input (W)	電流 Current (A)	轉速 Speed (RPM/min)	轉矩 Torque (kgf-cm)			
90	4	60	CM09IG60SAFV CM09IA60SAFV	100	50	CONT.	144	1.5	90	3.1	16 / 250	1.4	3
							99	1	1250	4.3			
				100	60	CONT.	146	1.5	90	3	16 / 250	1.5	3
							127	1.3	1600	4.5			
				110	50	CONT.	178	1.6	90	4	16 / 250	1.6	3.5
							110	1	1300	4.6			
			110	60	CONT.	179	1.6	90	3.7	16 / 250	1.6	3.6	
						119	1.1	1600	3.7				
			CM09IG60SBFV CM09IA60SBFV	220	50	CONT.	215	1	90	4.1	4 / 450	1	3.7
							110	0.5	1350	4.4			
				220	60	CONT.	210	1	90	4	4 / 450	1	3.7
							113	0.5	1650	3.7			
				230	50	CONT.	236	1	90	4.5	4 / 450	1	4
							118	0.5	1350	4.6			
			230	60	CONT.	232	1	90	4.5	4 / 450	1	4.2	
						116	0.5	1650	3.6				
240	50	CONT.	263	1.1	90	5	4 / 450	1	4.5				
			125	0.5	1350	4.5							
240	60	CONT.	255	1.1	90	4.9	4 / 450	1	4.7				
			126	0.5	1650	3.8							

如馬達特性變更，恕不另行通知，以馬達銘牌為準。

In case of change of motor characteristics, no further notice shall be given. The information shown on the nameplate of motor is taken as standard.

馬達線圖 Motor

CM09 □ 90FV

註：IA (*) 為 IA 型相關尺寸

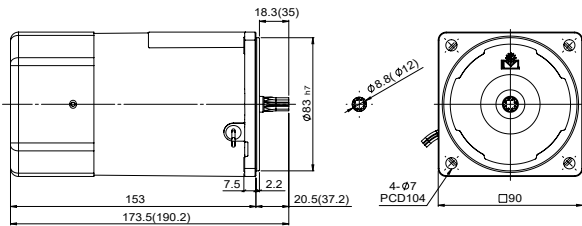

重量 Weight : 3.3kg ±5%

CM09 □ 90CFV

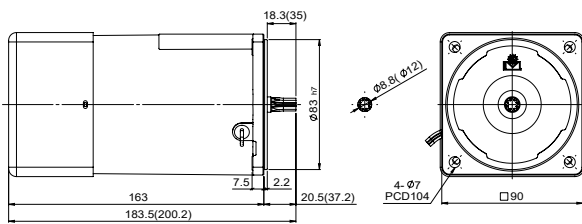

重量 Weight : 3.7kg ±5%

減速機線圖 Gear Head

CG09B □ S □

註：(*) 為 1/90~1/240 之尺寸

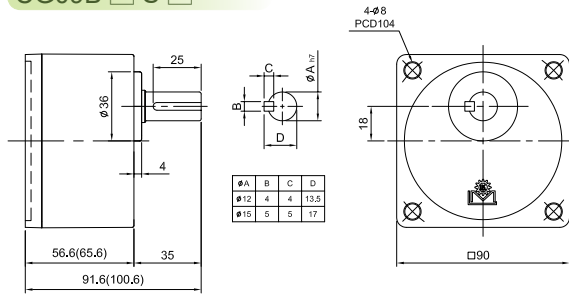

CG09B □ X

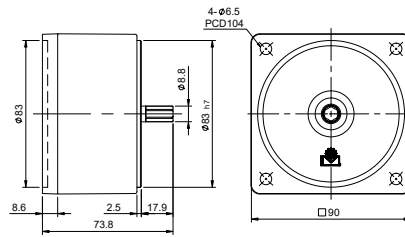

CGCU09B □ S □

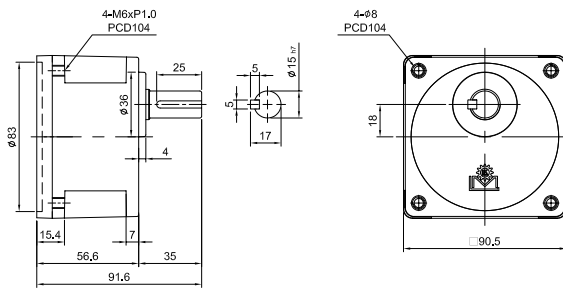

CGU09B □ S □

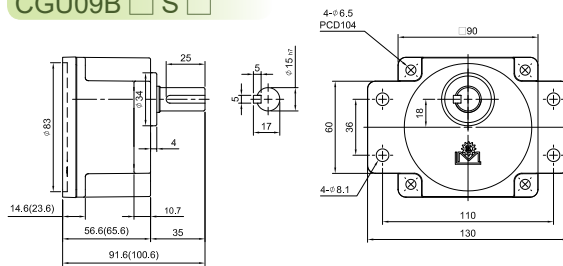

CGB09B □ H □

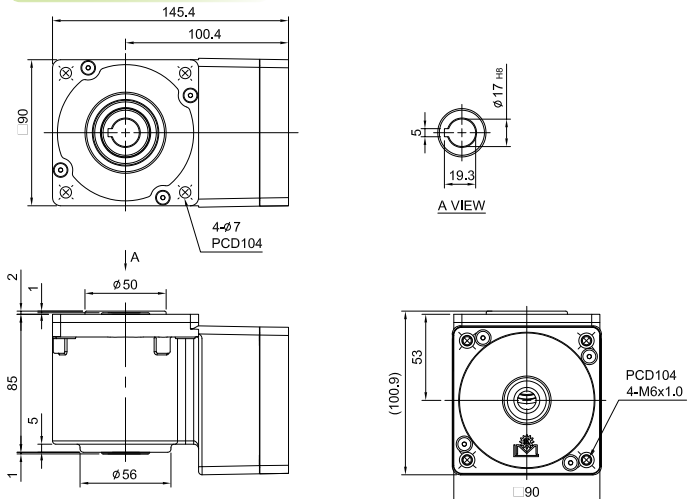

直接連結減速馬達時之容許轉矩 Permissible Torque of Direct Link Gearmotor

輸出功率 Output Power	馬達型號 Motor Model	減速機型號 Reducer Model	減速比 Ratio	轉速 Speed (RPM)		容許 Permissible (kgf-cm)		低速 Low Speed	減速機出力軸旋轉方向 Rotating direction of output shaft of speed reducer
				50Hz	60Hz	50Hz	60Hz		
90W	CM09IG90	CG09 □	3	500	600	18	14	30	(A) 與馬達同一方向旋轉 Rotating in the same direction as the motor
			5	300	360	28	24	18	
			6	250	300	34	28	15	
			7.5	200	240	43	35	12	
			9	166	200	51	42	10	
			12.5	120	144	71	60	7.2	
			15	100	120	85	70	6	
			18	83	100	96	80	5	(B) 與馬達相反方向旋轉 Rotating in the opposite direction to the motor
			25	60	72	125	103	3.6	
			30	50	60	150	124	3	
			36	42	50	178	149	2.5	
			50	30	36	200	200	1.8	
			60	25	30	200	200	1.5	(C) 與馬達同一方向旋轉 Rotating in the same direction as the motor
			75	20	24	200	200	1.2	
			90	17	20	200	200	1	
			100	15	18	200	200	0.9	
			120	12.5	15	200	200	0.75	
			150	10	12	200	200	0.6	
			180	8.3	10	200	200	0.5	
			200	7.5	9	200	200	-	
240	6.25	7.5	200	200	-				

直接連結減速馬達時之容許轉矩 (中空軸) Permissible Torque of Direct Link Gearmotor (Hollow Output Shaft)

輸出功率 Output Power	馬達型號 Motor Model	減速機型號 Reducer Model	減速比 Ratio / 頻率 (Hz)	轉速 RPM															
				9	15	18	22.5	27	37.5	45	54	75	90	108	150	180			
90W	CM09IG90	CGB09 □	50Hz	轉速 RPM	166	100	83	66	55	40	33	27	20	16	13	10	8.3		
				容許 Nm	4.9	8.2	9.9	12.3	14.8	20.6	24.7	29.7	29.7	29.7	29.7	29.7	29.7	29.7	
90W	CM09IG90	CGB09 □	60Hz	轉速 RPM	200	120	100	80	66	48	40	33	24	20	16	12	10		
				容許 Nm	4	6.8	8.1	10.2	12.2	17	20.4	24.4	24.4	24.4	24.4	24.4	24.4	24.4	
減速機出力軸旋轉方向 Rotating direction of output shaft of speed reducer				(A) 與馬達相反方向旋轉 Rotating in the opposite direction to the motor								(B) 與馬達同一方向旋轉 Rotating in the same direction as the motor							

90W 調速馬達規格表

框號尺寸 SIZE (mm)	極數 Poles (P)	輸出功率 Output (W)	規格 Type	電壓 Voltage (V)	頻率 Frequency (Hz)	負荷 Duty (min)	額定 Rated Load				電容器 Capacitor (μf/V)	啟動電流 Starting Current (A)	啟動轉矩 Starting Torque (kgf-cm)
							輸入功率 Input (W)	電流 Current (A)	轉速 Speed (RPM/min)	轉矩 Torque (kgf-cm)			
90	4	90	CM09IG90SAFV CM09IA90SAFV	100	50	CONT.	226	2.3	90	4	20 / 250	2.4	3.7
							142	1.4	1250	6.7			
				100	60	CONT.	218	2.2	90	4	20 / 250	2.2	4
							141	1.4	1550	5.6			
				110	50	CONT.	278	2.6	90	4.7	20 / 250	2.6	4.5
							152	1.3	1300	6.8			
			110	60	CONT.	264	2.4	90	5	20 / 250	2.5	5	
						148	1.4	1600	5.6				
			CM09IG90SBFV CM09IA90SBFV	220	50	CONT.	273	1.3	90	5.6	5 / 450	1.3	5.1
							147	0.68	1300	7.1			
				220	60	CONT.	257	1.2	90	5.1	5 / 450	1.2	5.1
							145	0.7	1600	5.4			
				230	50	CONT.	230	1.4	90	6.1	5 / 450	1.4	5.3
							144	0.6	1350	6.6			
230	60	CONT.		284	1.3	90	6	5 / 450	1.3	5.6			
				150	0.67	1650	5.3						
240	50	CONT.	329	1.4	90	6.6	5 / 450	1.4	5.9				
			150	0.6	1350	6.6							
240	60	CONT.	312	1.3	90	6.5	5 / 450	1.4	6				
			155	0.6	1650	5.3							

如馬達特性變更，恕不另行通知，以馬達銘牌為準。

In case of change of motor characteristics, no further notice shall be given. The information shown on the nameplate of motor is taken as standard.

單相可逆調速馬達

Single-Phase Reversible Speed Variable Motor



■ 單相可逆調速馬達 Single-Phase Reversible Speed Variable Motor

特徵：適用於單相馬達做速度調整控制。(50Hz: 90~14000rpm、60Hz: 90~1700rpm)
 (注：三相馬達做速度控制時一般則用變頻器控制)

Feature: Applicable for speed adjustment for single-phase motor
 (Note: The frequency converter is used for 3-phase motor, to control speed.)

■ 馬達一般規格 Motor General Specification

絕緣阻抗：在馬達的線圈與外殼間以 DC500V 高阻計測定，其數值在 100MΩ 以上。
 絕緣耐壓：在馬達的線圈與外殼間施加 50Hz 或 60Hz、1.5KV、1 分鐘無發生異常現象。
 溫度上升：於馬達額定運轉後以電阻法測定，溫度上升值在 80°C 以下。
 絕緣等級：B 種 (130°C)
 保護等級：導線型 IP20，端子盒型 IP54。
 使用溫度：-10°C ~+50°C (電容連續運轉馬達 -10°C ~+40°C) (不結凍狀態)。
 使用濕度：85% 以下 (不結露狀態)。
 強制風扇 (選配)：電壓 AC(110V,220V) 提供馬達低轉速時加強散熱。

Insulation impedance: Measure with DC500V high resistance gauge between the coil and casing of motor, the reading is 100M or higher.

Insulation resistance to pressure: Apply 50Hz or 60Hz, 1.5V between the coil and casing of motor for one minute without irregularity resulted.

Temperature rise: To specify by resistance method after motor reaches rated operation, temperature is less than 80°C .

Insulation: B (130°C)

Protection: Motor with conductive wire is IP20; motor with terminal box is IP54.

Operating temperature: -10°C ~+50°C (Capacitor operation motor -10°C ~+40°C) (No freezing)

Operating humidity: 85% or less (No condensation)

Electronic Fan (Optional): Voltage AC (110V, 220V) helps to dissipate heat at low motor speeds.

■ 可逆調速馬達機構 Reversible Speed Variable Motor Machinery

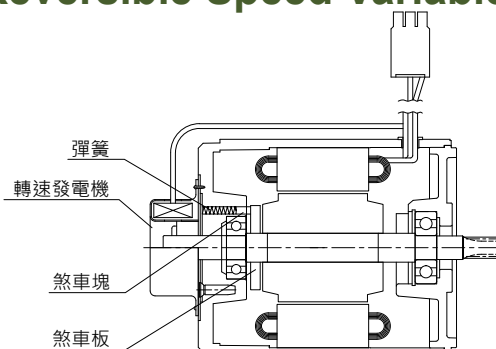

單相可逆調速馬達 Single Phase Reversible Speed Variable Motor

單相可逆調速馬達

60 mm
6W

馬達線圖 Motor

CM06 □ 6V

註：IA (*) 為 IA 型相關尺寸

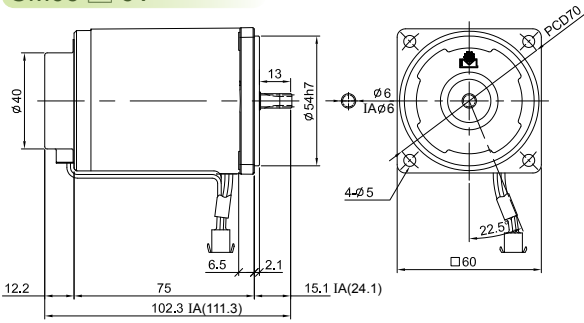

重量 Weight : 1kg ±5%

減速機線圖 Gear Head

CG06B □ S □

註：(*) 為 1/90~1/300 之尺寸

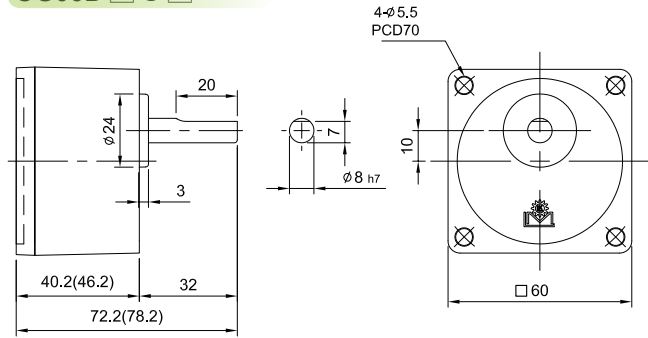

直接連結減速馬達時之容許轉矩 Permissible Torque of Direct Link Gearmotor

輸出功率 Output Power	馬達型號 Motor Model	減速機型號 Reducer Model	減速比 Ratio	轉速 Speed (RPM)		容許 Permissible (kgf·cm)		低速 Low Speed	減速機出力軸旋轉方向 Rotating direction of output shaft of speed reducer
				50Hz	60Hz	50Hz	60Hz		
6W	CM06RG06	CG06 □	3	500	600	1.2	1.0	30	(A) 與馬達同一方向旋轉 Rotating in the same direction as the motor
			5	300	360	1.9	1.5	18	
			6	250	300	2.3	1.8	15	
			7.5	200	240	2.9	2.3	12	
			9	166	200	3.4	2.8	10	
			12.5	120	144	4.7	3.9	7.2	
			15	100	120	5.7	4.7	6	(B) 與馬達相反方向旋轉 Rotating in the opposite direction to the motor
			18	83	100	6.8	5.6	5	
			25	60	72	9.3	7.0	3.6	
			30	50	60	11	8.3	3	
			36	42	50	13	10	2.5	
			50	30	36	16	13.8	1.8	
			60	25	30	20	16	1.5	(C) 與馬達同一方向旋轉 Rotating in the same direction as the motor
			75	20	24	24	20	1.2	
			90	17	20	30	24	1	
			100	15	18	30	30	0.9	
			120	12.5	15	30	30	0.75	
			150	10	12	30	30	0.6	
180	8.3	10	30	30	0.5				
200	7.5	9	30	30	-				
240	6.25	7.5	30	30	-				
300	5	6	30	30	-				

6W 可逆調速馬達規格表

框號尺寸 SIZE (mm)	極數 Poles (P)	輸出功率 Output (W)	規格 Type	電壓 Voltage (V)	頻率 Frequency (Hz)	負荷 Duty (min)	額定 Rated Load				電容器 Capacitor (µf/V)	啟動電流 Starting Current (A)	啟動轉矩 Starting Torque (kgf·cm)
							輸入功率 Input (W)	電流 Current (A)	轉速 Speed (RPM/min)	轉矩 Torque (kgf·cm)			
60	4	6	CM06RG6SAV CM06RA9SAV	100	50	30	33	0.34	90	0.56	4 / 250	0.34	0.54
							25	0.26	1300	0.44			
				100	60	30	35	0.35	90	0.57	4 / 250	0.35	0.55
							26	0.26	1600	0.41			
				110	50	30	38	0.35	90	0.5	3 / 250	0.35	0.46
							27	0.26	1300	0.43			
			110	60	30	37	0.34	90	0.53	3 / 250	0.34	0.48	
						26	0.24	1600	0.41				
			CM06RG6SBV CM06RA6SBV	230	50	30	30	0.13	90	0.63	0.8 / 450	0.13	0.73
							24	0.1	1300	0.46			
				230	60	30	33	0.14	90	0.65	0.8 / 450	0.15	0.75
							29	0.12	1600	0.35			
240	50	30		33	0.13	90	0.7	0.8 / 450	0.14	0.8			
				26	0.11	1300	0.47						
240	60	30	36	0.15	90	0.7	0.8 / 450	0.15	0.84				
				0.13	1600	0.34							

如馬達特性變更，恕不另行通知，以馬達銘牌為準。

In case of change of motor characteristics, no further notice shall be given. The information shown on the nameplate of motor is taken as standard.

馬達線圖 Motor

CM07 □ 15V

註：IA (*) 為 IA 型相關尺寸

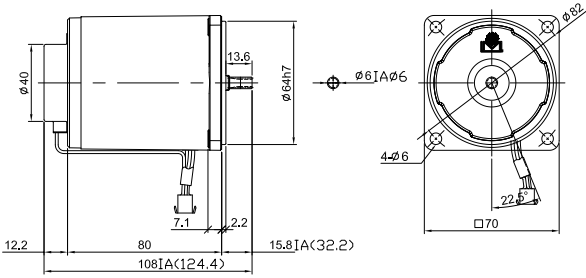

減速機線圖 Gear Head

CG07B □ S □

註：(*) 為 1/90~1/240 之尺寸

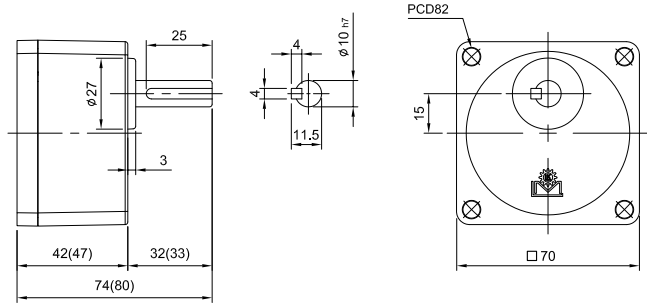

重量 Weight : 1.4kg ±5%

直接連結減速馬達時之容許轉矩 Permissible Torque of Direct Link Gearmotor

輸出功率 Output Power	馬達型號 Motor Model	減速機型號 Reducer Model	減速比 Ratio	轉速 Speed (RPM)		容許 Permissible (kgf-cm)		低速 Low Speed	減速機出力軸旋轉方向 Rotating direction of output shaft of speed reducer
				50Hz	60Hz	50Hz	60Hz		
15W	CM07RG15	CG07 □	3	500	600	3.0	2.6	30	(A) 與馬達同一方向旋轉 Rotating in the same direction as the motor
			5	300	360	4.7	3.9	18	
			6	250	300	5.7	4.7	15	
			7.5	200	240	7.1	5.8	12	
			9	166	200	8.5	7.0	10	
			12.5	120	144	11.8	9.8	7.2	
			15	100	120	14.2	11.8	6	
			18	83	100	18	15	5	(B) 與馬達相反方向旋轉 Rotating in the opposite direction to the motor
			25	60	72	23	19	3.6	
			30	50	60	28	23	3	
			36	42	50	33	27.6	2.5	
			50	30	36	46	38.4	1.8	
			60	25	30	50	46	1.5	
			75	20	24	50	50	1.2	
			90	17	20	50	50	1	(C) 與馬達同一方向旋轉 Rotating in the same direction as the motor
			100	15	18	50	50	0.9	
			120	12.5	15	50	50	0.75	
			150	10	12	50	50	0.6	
			180	8.3	10	50	50	0.5	
			200	7.5	9	50	-	-	
240	6.25	7.5	50	-	-				
300	5	6	-	-	-				

15W 可逆調速馬達規格表

框號尺寸 SIZE (mm)	極數 Poles (P)	輸出功率 Output (W)	規格 Type	電壓 Voltage (V)	頻率 Frequency (Hz)	負荷 Duty (min)	額定 Rated Load				電容器 Capacitor (μf/V)	啟動電流 Starting Current (A)	啟動轉矩 Starting Torque (kgf-cm)
							輸入功率 Input (W)	電流 Current (A)	轉速 Speed (RPM/min)	轉矩 Torque (kgf-cm)			
70	4	15	CM07RG15SAV CM07RA15SAV	100	50	30	57	0.6	90	1	4 / 250	0.6	1
							37	0.38	1250	1.1			
				100	60	30	55	0.57	90	1	4 / 250	0.57	1
							38	0.38	1550	1			
				110	50	30	70	0.66	90	1.3	3 / 250	0.66	1.3
							42	0.41	1300	1.1			
			110	60	30	67	0.63	90	1.3	3 / 250	0.63	1.3	
						42	0.39	1600	1				
			CM07RG15SBV CM07RA15SBV	220	50	30	78	0.37	90	1.3	1.5 / 450	0.37	1
							48	0.24	1300	1.1			
				220	60	30	75	0.35	90	1.2	1.5 / 450	0.35	1
							44	0.2	1300	1			
				230	50	30	86	0.39	90	1.4	1.5 / 450	0.39	1.23
							52	0.25	1300	1.1			
230	60	30		81	0.36	90	1.4	1.5 / 450	0.36	1.12			
				48	0.21	1300	1						
240	50	30	93	0.4	90	1.5	1.5 / 450	0.4	1.3				
			57	0.27	1300	1.2							
240	60	30	89	0.38	90	1.5	1.5 / 450	0.38	1.3				
			53	0.22	1300	1.1							

如馬達特性變更，恕不另行通知，以馬達銘牌為準。

In case of change of motor characteristics, no further notice shall be given. The information shown on the nameplate of motor is taken as standard.

馬達線圖 Motor

CM08 □ 25V

註：IA (*) 為 IA 型相關尺寸

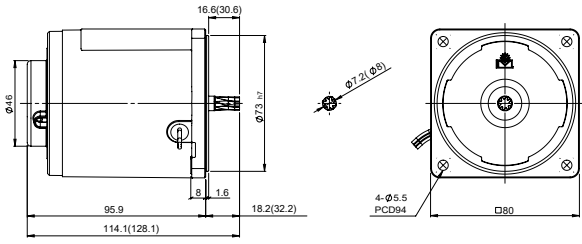

重量 Weight : 1.5kg ±5%

減速機線圖 Gear Head

CG08B □ S □

註：(*) 為 1/90~1/300 之尺寸

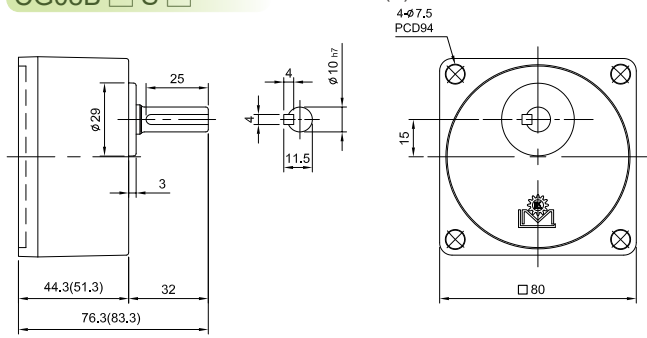

CG08B □ X

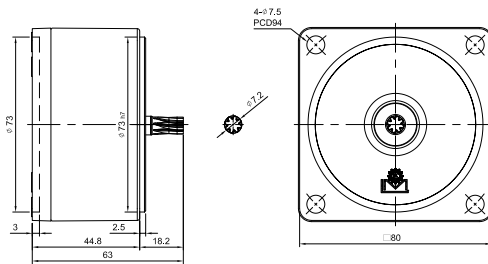

直接連結減速馬達時之容許轉矩 Permissible Torque of Direct Link Gearmotor

輸出功率 Output Power	馬達型號 Motor Model	減速機型號 Reducer Model	減速比 Ratio	轉速 Speed (RPM)		容許 Permissible (kgf·cm)		低速 Low Speed	減速機出力軸旋轉方向 Rotating direction of output shaft of speed reducer
				50Hz	60Hz	50Hz	60Hz		
25W	CM08RG25	CG08 □	3	500	600	5.0	4.1	30	(A) 與馬達同一方向旋轉 Rotating in the same direction as the motor
			5	300	360	7.8	6.3	18	
			6	250	300	9.4	7.6	15	
			7.5	200	240	11.8	9.5	12	
			9	166	200	14.1	11.4	10	
			12.5	120	144	19.6	16	7.2	
			15	100	120	23	19	6	
			18	83	100	28	23	5	
			25	60	72	38	31	3.6	(B) 與馬達相反方向旋轉 Rotating in the opposite direction to the motor
			30	50	60	46	37	3	
			36	42	50	55	45	2.5	
			50	30	36	76	62	1.8	
			60	25	30	80	75	1.5	
			75	20	24	80	80	1.2	
			90	17	20	80	80	1	(C) 與馬達同一方向旋轉 Rotating in the same direction as the motor
			100	15	18	80	80	0.9	
			120	12.5	15	80	80	0.75	
			150	10	12	80	80	0.6	
			180	8.3	10	80	80	0.5	
			200	7.5	9	80	80	-	
240	6.25	7.5	80	80	-				
300	5	6	80	80	-				

25W 可逆調速馬達規格表

框號尺寸 SIZE (mm)	極數 Poles (P)	輸出功率 Output (W)	規格 Type	電壓 Voltage (V)	頻率 Frequency (Hz)	負荷 Duty (min)	額定 Rated Load				電容器 Capacitor (μ f/V)	啟動電流 Starting Current (A)	啟動轉矩 Starting Torque (kgf·cm)
							輸入功率 Input (W)	電流 Current (A)	轉速 Speed (RPM/min)	轉矩 Torque (kgf·cm)			
80	4	25	CM08RG25SAV CM08RA25SAV	100	50	30	99	0.89	90	1.4	6 / 250	0.89	1.1
							46	0.5	1250	1.9			
				100	60	30	99	0.84	90	1.3			
							41	0.42	1550	1.5			
				110	50	30	104	1	90	1.6			
							49	0.5	1300	1.9			
			110	60	30	99	0.9	90	1.6				
						43	0.4	1640	1.4				
			CM08RG25SBV CM08RA25SBV	220	50	30	98	0.46	90	2	2 / 450	0.46	1.9
							59	0.27	1250	1.9			
				220	60	30	97	0.44	90	2			
							58	0.26	1550	1.5			
				230	50	30	106	0.47	90	2.3			
							60	0.27	1250	1.9			
			230	60	30	105	0.46	90	2.2				
						61	0.26	1600	1.5				
			240	50	30	116	0.49	90	2.4	2 / 450	0.49	2.2	
						63	0.27	1300	1.8				
240	60	30	114	0.48	90	2.5	2 / 450	0.48	2.2				
			65	0.27	1600	1.5							

如馬達特性變更，恕不另行通知，以馬達銘牌為準。

In case of change of motor characteristics, no further notice shall be given. The information shown on the nameplate of motor is taken as standard.

馬達線圖 Motor

CM09 □ 40V

註：IA (*) 為 IA 型相關尺寸

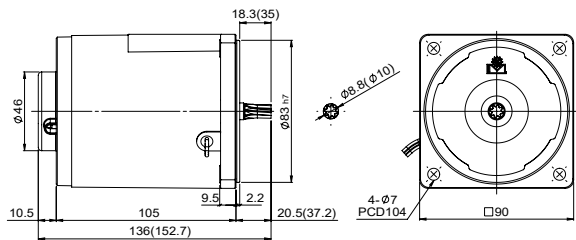

重量 Weight : 2.3kg \pm 5%

CM09 □ 40CFV

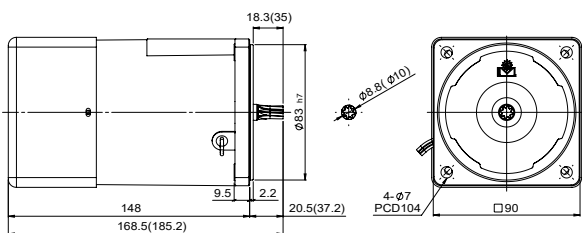

重量 Weight : 2.8kg \pm 5%

減速機線圖 Gear Head

CG09B □ S □

註：(*) 為 1/90~1/240 之尺寸

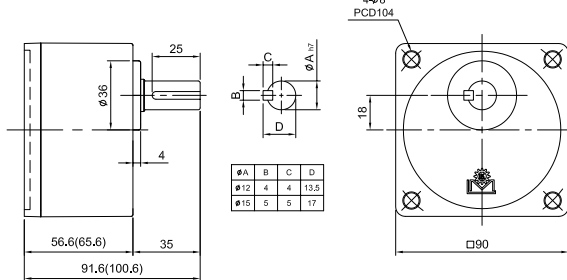

CG09B □ X

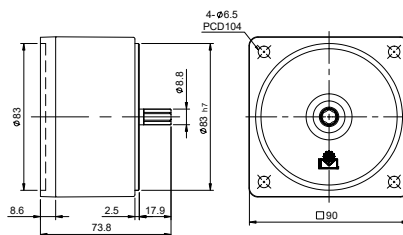

CGCU09B □ S □

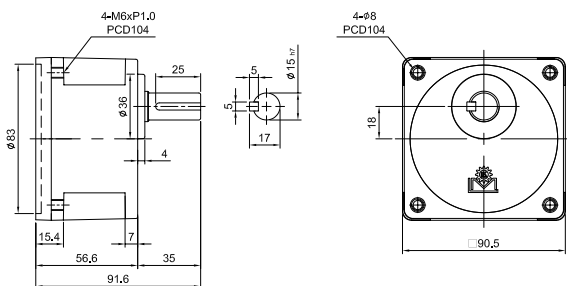

CGU09B □ S □

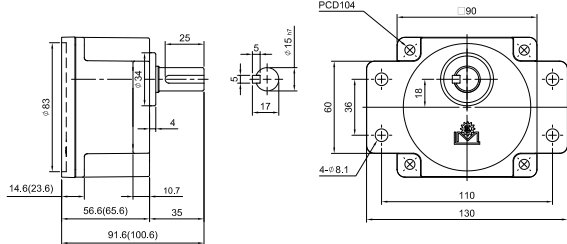

CGB09B □ H □

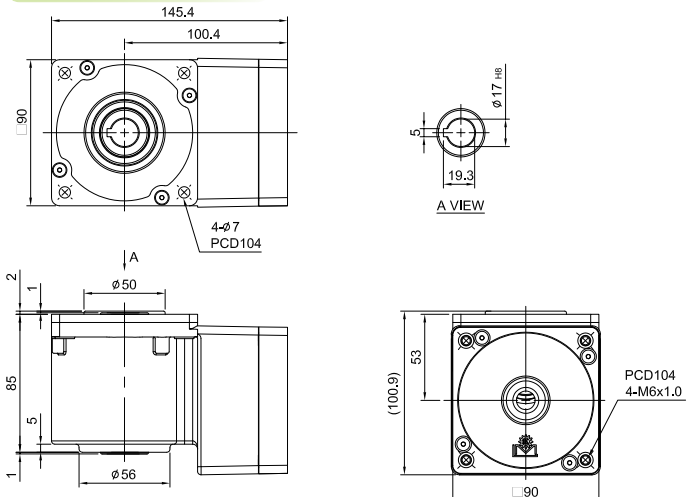

直接連結減速馬達時之容許轉矩 Permissible Torque of Direct Link Gearmotor

輸出功率 Output Power	馬達型號 Motor Model	減速機型號 Reducer Model	減速比 Ratio	轉速 Speed (RPM)		容許 Permissible (kgf-cm)		低速 Low Speed	減速機出力軸旋轉方向 Rotating direction of output shaft of speed reducer
				50Hz	60Hz	50Hz	60Hz		
40W	CM09RG40	CG09 □	3	500	600	7.3	6.3	30	(A) 與馬達同一方向旋轉 Rotating in the same direction as the motor
			5	300	360	12	10	18	
			6	250	300	14.7	12	15	
			7.5	200	240	18	15	12	
			9	166	200	22	19	10	
			12.5	120	144	30	26	7.2	
			15	100	120	36	30	6	(B) 與馬達相反方向旋轉 Rotating in the opposite direction to the motor
			18	83	100	43	37	5	
			25	60	72	54	45	3.6	
			30	50	60	65	54	3	
			36	42	50	77	65	2.5	
			50	30	36	100	90	1.8	
			60	25	30	100	100	1.5	(C) 與馬達同一方向旋轉 Rotating in the same direction as the motor
			75	20	24	100	100	1.2	
			90	17	20	100	100	1	
			100	15	18	100	100	0.9	
			120	12.5	15	100	100	0.75	
			150	10	12	100	100	0.6	
180	8.3	10	100	100	0.5				
200	7.5	9	100	100	-				
			240	6.25	7.5	100	100	-	

直接連結減速馬達時之容許轉矩 (中空軸) Permissible Torque of Direct Link Gearmotor (Hollow Output Shaft)

輸出功率 Output Power	馬達型號 Motor Model	減速機型號 Reducer Model	減速比 Ratio / 頻率 (Hz)	9	15	18	22.5	27	37.5	45	54	75	90	108	150	180	
				40W	CM09RG40	CGB09 □	50Hz	轉速 RPM 容許 Nm	166 2	100 3.4	83 4	66 5.1	55 6.1	40 8.5	33 10.2	27 12.2	20 12.2
			60Hz	轉速 RPM 容許 Nm	200 1.7	120 2.9	100 3.4	80 4.3	66 5.2	48 7.2	40 8.7	33 10.4	24 10.4	20 10.4	16 10.4	12 10.4	10 10.4
減速機出力軸旋轉方向 Rotating direction of output shaft of speed reducer				(A) 與馬達相反方向旋轉 Rotating in the opposite direction to the motor									(B) 與馬達同一方向旋轉 Rotating in the same direction as the motor				

40W 可逆調速馬達規格表

框號尺寸 SIZE (mm)	極數 Poles (P)	輸出功率 Output (W)	規格 Type	電壓 Voltage (V)	頻率 Frequency (Hz)	負荷 Duty (min)	額定 Rated Load				電容器 Capacitor (μf/V)	啟動電流 Starting Current (A)	啟動轉矩 Starting Torque (kgf-cm)
							輸入功率 Input (W)	電流 Current (A)	轉速 Speed (RPM/min)	轉矩 Torque (kgf-cm)			
90	4	40	CM09RG40SAV CM09RA40SAV	100	50	30	170	1.8	90	2.4	12 / 250	1.8	2.3
							77	0.8	1350	3			
				100	60	30	160	1.7	90	2.4	12 / 250	1.7	2.2
							76	0.7	1650	2.7			
				110	50	30	205	1.9	90	2.9	12 / 250	2	2.6
							87	0.85	1650	3			
			110	60	30	193	1.83	90	2.9	12 / 250	1.8	2.8	
						99	0.9	1600	3.9				
			CM09RG40SBV CM09RA40SBV	220	50	30	131	0.6	90	3	4 / 450	0.6	2.8
							80	0.37	1300	3			
				220	60	30	130	0.6	90	3	4 / 450	0.6	3
							96	0.47	1600	2.5			
				230	50	30	144	0.63	90	3.3	4 / 450	0.64	3
							87	0.38	1300	3.4			
			230	60	30	143	0.63	90	3.3	4 / 450	0.62	3.3	
						102	0.47	1600	2.5				
240	50	30	156	0.66	90	3.6	4 / 450	0.66	3.5				
			92	0.4	1300	3.5							
240	60	30	157	0.66	90	3.6	4 / 450	0.65	3.4				
			107	0.48	1600	2.5							

如馬達特性變更，恕不另行通知，以馬達銘牌為準。

In case of change of motor characteristics, no further notice shall be given. The information shown on the nameplate of motor is taken as standard.

馬達線圖 Motor

CM09 □ 60FV

註：IA (*) 為 IA 型相關尺寸

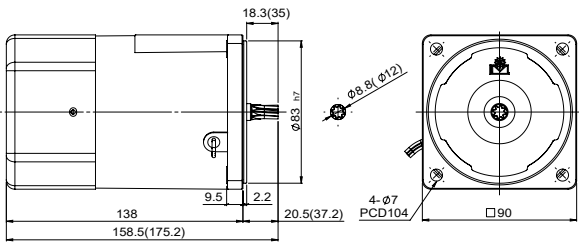

重量 Weight : 2.5kg ±5%

CM09 □ 60CFV

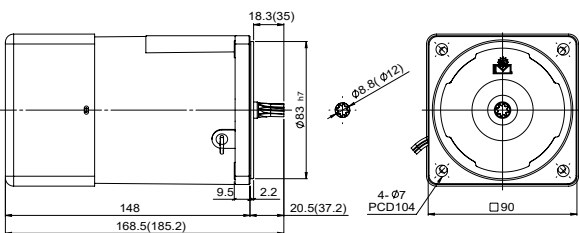

重量 Weight : 2.8kg ±5%

減速機線圖 Gear Head

CG09B □ S □

註：(*) 為 1/90~1/240 之尺寸

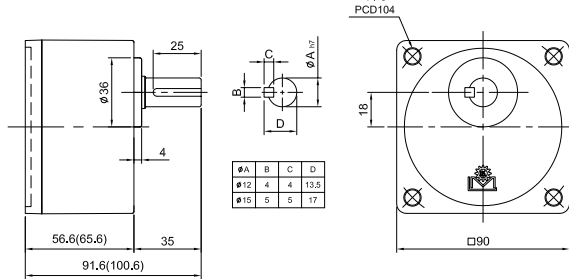

CG09B □ X

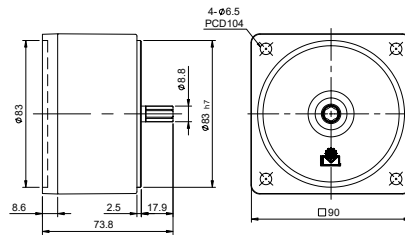

CGCU09B □ S □

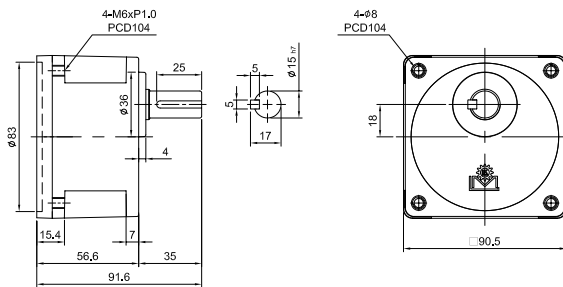

CGU09B □ S □

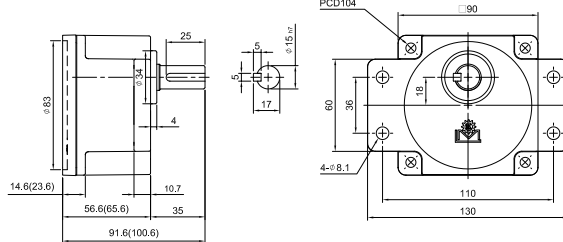

CGB09B □ H □

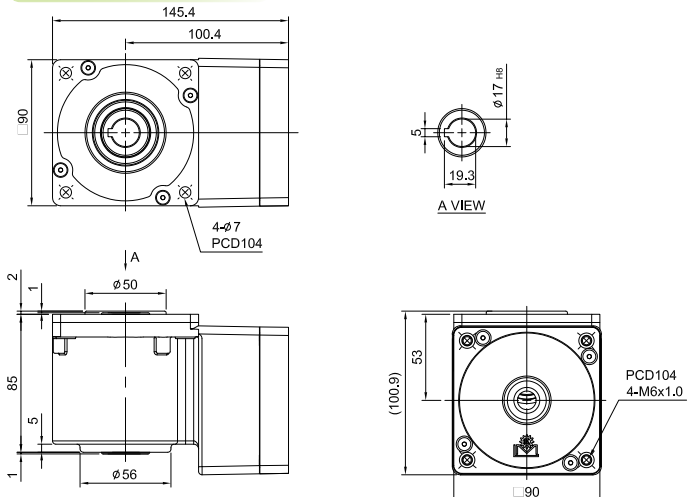

直接連結減速馬達時之容許轉矩 Permissible Torque of Direct Link Gearmotor

輸出功率 Output Power	馬達型號 Motor Model	減速機型號 Reducer Model	減速比 Ratio	轉速 Speed (RPM)		容許 Permissible (kgf-cm)		低速 Low Speed	減速機出力軸旋轉方向 Rotating direction of output shaft of speed reducer
				50Hz	60Hz	50Hz	60Hz		
60W	CM09RG60	CG09 □	3	500	600	12	9.8	30	(A) 與馬達同一方向旋轉 Rotating in the same direction as the motor
			5	300	360	19	16	18	
			6	250	300	22	19	15	
			7.5	200	240	28	24	12	
			9	166	200	34	28	10	
			12.5	120	144	48	40	7.2	
			15	100	120	55	47	6	(B) 與馬達相反方向旋轉 Rotating in the opposite direction to the motor
			18	83	100	62	55	5	
			25	60	72	82	69	3.6	
			30	50	60	98	83	3	
			36	42	50	118	100	2.5	
			50	30	36	164	138	1.8	
			60	25	30	196	160	1.5	(C) 與馬達同一方向旋轉 Rotating in the same direction as the motor
			75	20	24	200	175	1.2	
			90	17	20	200	200	1	
			100	15	18	200	200	0.9	
			120	12.5	15	200	200	0.75	
			150	10	12	200	200	0.6	
180	8.3	10	200	200	0.5				
200	7.5	9	200	200	-				
			240	6.25	7.5	200	200	-	

直接連結減速馬達時之容許轉矩 (中空軸) Permissible Torque of Direct Link Gearmotor (Hollow Output Shaft)

輸出功率 Output Power	馬達型號 Motor Model	減速機型號 Reducer Model	減速比 Ratio / 頻率 (Hz)	9	15	18	22.5	27	37.5	45	54	75	90	108	150	180	
				60W	CM09RG60	CGB09 □	50Hz	轉速 RPM 容許 Nm	166 3.2	100 5.4	83 6.5	66 8.2	55 9.8	40 13.6	33 16.4	27 19.6	20 19.6
			60Hz	轉速 RPM 容許 Nm	200 2.6	120 4.3	100 5.2	80 6.5	66 7.8	48 10.9	40 13.1	33 15.7	24 15.7	20 15.7	16 15.7	12 15.7	10 15.7
減速機出力軸旋轉方向 Rotating direction of output shaft of speed reducer				(A) 與馬達相反方向旋轉 Rotating in the opposite direction to the motor									(B) 與馬達同一方向旋轉 Rotating in the same direction as the motor				

60W 可逆調速馬達規格表

框號尺寸 SIZE (mm)	極數 Poles (P)	輸出功率 Output (W)	規格 Type	電壓 Voltage (V)	頻率 Frequency (Hz)	負荷 Duty (min)	額定 Rated Load				電容器 Capacitor (μ f/V)	啟動電流 Starting Current (A)	啟動轉矩 Starting Torque (kgf-cm)
							輸入功率 Input (W)	電流 Current (A)	轉速 Speed (RPM/min)	轉矩 Torque (kgf-cm)			
90	4	60	CM09RG60SAFV CM09RA60SAFV	100	50	30	161	1.6	90	3.7	20 / 250	1.6	3.7
							115	1.2	1250	4.6			
				100	60	30	165	1.6	90	3.8	20 / 250	1.6	3.8
							131	1.3	1550	3.6			
				110	50	30	192	1.7	90	4.6	20 / 250	1.7	4.4
							120	1.1	1300	4.5			
			110	60	30	199	1.8	90	4.7	20 / 250	1.8	4.7	
						145	1.4	1600	3.6				
			CM09RG60SBFV CM09RA60SBFV	220	50	30	223	1	90	4.1	4 / 450	1	3.7
							110	0.5	1350	4.4			
				220	60	30	218	1	90	4	4 / 450	1	3.7
							113	0.5	1650	3.5			
				230	50	30	245	1	90	4.5	4 / 450	1	4
							118	0.5	1350	4.4			
				230	60	30	238	1	90	4.4	4 / 450	1	4
							118	0.5	1650	3.5			
240	50	30		263	1.1	90	5	4 / 450	1	4.4			
				128	0.5	1350	4.5						
240	60	30	258	1.1	90	4.7	4 / 450	1	4.7				
			128	0.5	1650	3.7							

如馬達特性變更，恕不另行通知，以馬達銘牌為準。

In case of change of motor characteristics, no further notice shall be given. The information shown on the nameplate of motor is taken as standard.

馬達線圖 Motor

CM09 □ 90FV

註：IA (*) 為 IA 型相關尺寸

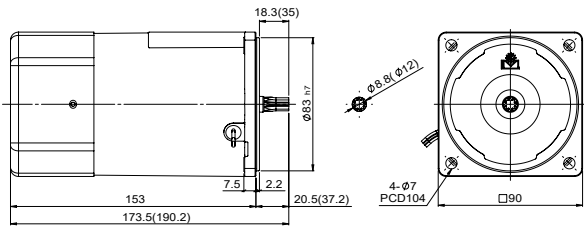

重量 Weight : 3.3kg ±5%

CM09 □ 90CFV

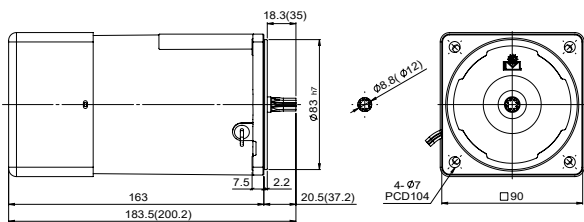

重量 Weight : 3.7kg ±5%

減速機線圖 Gear Head

CG09B □ S □

註：(*) 為 1/90~1/240 之尺寸

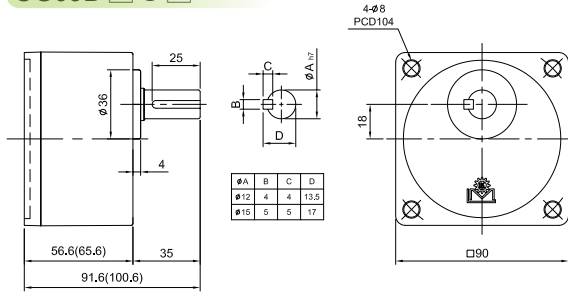

CG09B □ X

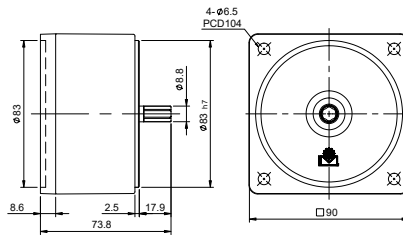

CGCU09B □ S □

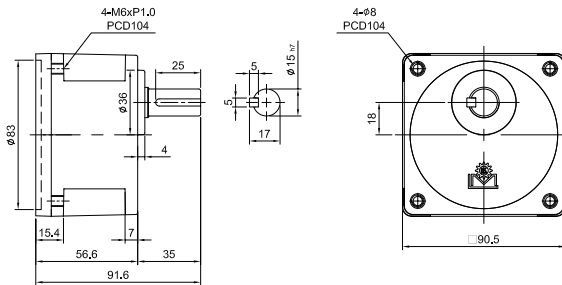

CGU09B □ S □

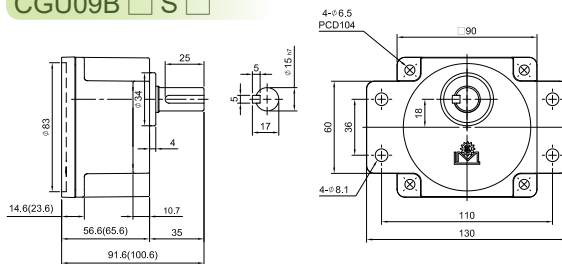

CGB09B □ H □

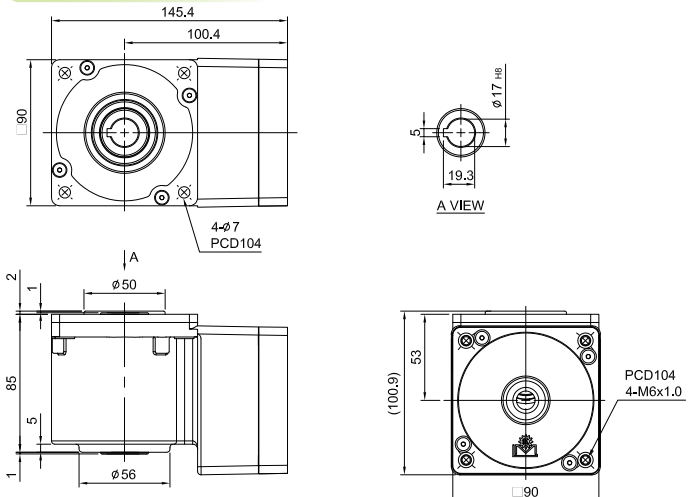

直接連結減速馬達時之容許轉矩 Permissible Torque of Direct Link Gearmotor

輸出功率 Output Power	馬達型號 Motor Model	減速機型號 Reducer Model	減速比 Ratio	轉速 Speed (RPM)		容許 Permissible (kgf·cm)		低速 Low Speed	減速機出力軸旋轉方向 Rotating direction of output shaft of speed reducer
				50Hz	60Hz	50Hz	60Hz		
90W	CM09RG90	CG09 □	3	500	600	18	14	30	(A) 與馬達同一方向旋轉 Rotating in the same direction as the motor
			5	300	360	28	24	18	
			6	250	300	34	28	15	
			7.5	200	240	43	35	12	
			9	166	200	51	42	10	
			12.5	120	144	71	60	7.2	
			15	100	120	85	70	6	
			18	83	100	96	80	5	(B) 與馬達相反方向旋轉 Rotating in the opposite direction to the motor
			25	60	72	125	103	3.6	
			30	50	60	150	124	3	
			36	42	50	178	149	2.5	
			50	30	36	200	200	1.8	
			60	25	30	200	200	1.5	(C) 與馬達同一方向旋轉 Rotating in the same direction as the motor
			75	20	24	200	200	1.2	
			90	17	20	200	200	1	
			100	15	18	200	200	0.9	
			120	12.5	15	200	200	0.75	
			150	10	12	200	200	0.6	
180	8.3	10	200	200	0.5				
200	7.5	9	200	200	-				
			240	6.25	7.5	200	200	-	

直接連結減速馬達時之容許轉矩 (中空軸) Permissible Torque of Direct Link Gearmotor (Hollow Output Shaft)

輸出功率 Output Power	馬達型號 Motor Model	減速機型號 Reducer Model	減速比 Ratio / 頻率 (Hz)	轉速 RPM														
				9	15	18	22.5	27	37.5	45	54	75	90	108	150	180		
90W	CM09RG90	CGB09 □	50Hz	轉速 RPM	166	100	83	66	55	40	33	27	20	16	13	10	8.3	
				容許 Nm	4.8	8	9.6	12	14.4	20	24	28.8	28.8	28.8	28.8	28.8	28.8	28.8
			60Hz	轉速 RPM	200	120	100	80	66	48	40	33	24	20	16	12	10	
				容許 Nm	3.9	6.5	7.8	9.8	11.8	16.4	19.6	23.6	23.6	23.6	23.6	23.6	23.6	23.6
減速機出力軸旋轉方向 Rotating direction of output shaft of speed reducer				(A) 與馬達相反方向旋轉 Rotating in the opposite direction to the motor							(B) 與馬達同一方向旋轉 Rotating in the same direction as the motor							

90W 可逆調速馬達規格表

框號尺寸 SIZE (mm)	極數 Poles (P)	輸出功率 Output (W)	規格 Type	電壓 Voltage (V)	頻率 Frequency (Hz)	負荷 Duty (min)	額定 Rated Load				電容器 Capacitor (μ f/V)	啟動電流 Starting Current (A)	啟動轉矩 Starting Torque (kgf·cm)
							輸入功率 Input (W)	電流 Current (A)	轉速 Speed (RPM/min)	轉矩 Torque (kgf·cm)			
90	4	90	CM09RG90SAFV CM09RA90SAFV	100	50	30	240	2.5	90	4.7	24 / 250	2.5	4.7
							147	1.5	1300	6.7			
				100	60	30	235	2.4	90	5	24 / 250	2.4	4.8
							160	1.6	1600	5.6			
				110	50	30	291	2.7	90	6	24 / 250	2.7	5.7
							155	1.4	1350	6.6			
			110	60	30	285	2.6	90	5.8	24 / 250	2.7	5.8	
						170	1.6	1650	5.4				
			CM09RG90SBFV CM09RA90SBFV	220	50	30	288	1.3	90	6.5	6 / 450	1.3	6.1
							151	0.7	1350	6.5			
				220	60	30	280	1.3	90	6.5	6 / 450	1.3	6.3
							173	0.8	1600	5.4			
				230	50	30	318	1.4	90	7.3	6 / 450	1.4	6.6
							157	0.7	1350	6.5			
				230	60	30	306	1.3	90	7.1	6 / 450	1.4	6.9
							180	0.8	1650	5.2			
240	50	30		343	1.5	90	8	6 / 450	1.4	7.4			
				163	0.7	1350	6.5						
240	60	30	334	1.4	90	7.6	6 / 450	1.4	7.6				
			188	0.8	1650	5.3							

如馬達特性變更，恕不另行通知，以馬達銘牌為準。

In case of change of motor characteristics, no further notice shall be given. The information shown on the nameplate of motor is taken as standard.

電磁剎車馬達

Electromagnetic Brake Motor

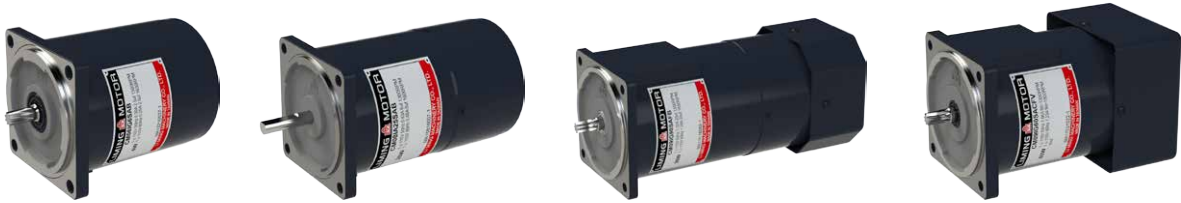

電磁剎車馬達 Electromagnetic Brake Motor

特徵：適用於單相或三相馬達緊急剎車作業。在電源斷電的時候，馬達會瞬間停止並具有負載保持力。

Feature: Applicable to single-phase or 3-phase emergency brake.

When power is interrupted, motor will instantly stop and maintain the loading.

馬達一般規格 Motor General Specification

絕緣阻抗：在馬達的線圈與外殼間以 DC500V 高阻計測定，其數值在 100MΩ 以上。

絕緣耐壓：在馬達的線圈與外殼間施加 50Hz 或 60Hz、1.5KV、1 分鐘無發生異常現象。

溫度上升：於馬達額定運轉後以電阻法測定，溫度上升值在 80°C 以下。

絕緣等級：B 種 (130°C)

保護等級：導線型 IP20。

使用溫度：-10°C ~+50°C (電容連續運轉馬達 -10°C ~+40°C) (不結凍狀態)。

使用濕度：85% 以下 (不結露狀態)。

強制風扇 (選配)：電壓 AC(110V,220V) 提供馬達強制性散熱 (送電狀態下)。

Insulation impedance: Measure with DC500V high resistance gauge between the coil and casing of motor, the reading is 100M or higher.

Insulation resistance to pressure: Apply 50Hz or 60Hz, 1.5V between the coil and casing of motor for one minute without irregularity resulted.

Temperature rise: To specify by resistance method after motor reaches rated operation, temperature is less than 80°C.

Insulation: B (130°C)

Protection: Motor with conductive wire is IP20.

Operating temperature: -10°C ~+50°C (Capacitor operation motor -10°C ~+40°C) (No freezing)

Operating humidity: 85% or less (No condensation)

Electronic Fan (Optional): Voltage AC (110V, 220V) helps to dissipate heat at low motor speeds.

電磁剎車馬達接線圖 Electromagnetic Brake Motor Wiring Diagram

◆單相 Single-Phase

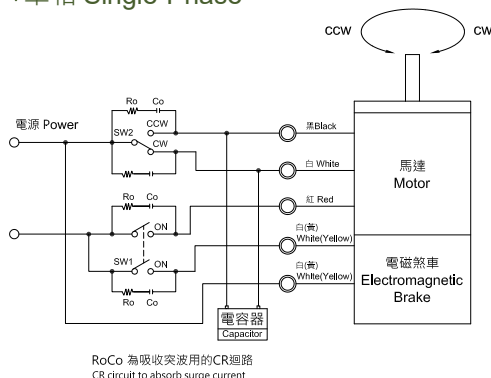

◆三相 3-Phase

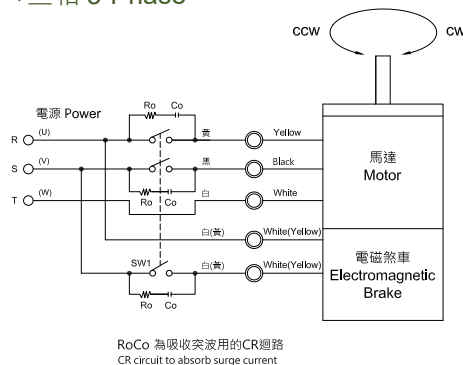

馬達線圖 Motor

CM06 □ 6B 註：IA (*) 為 IA 型相關尺寸

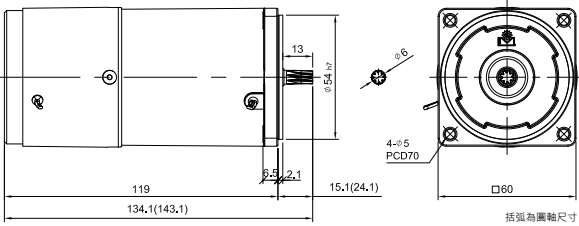

重量 Weight : 1.1kg ±5%

CM07 □ 15B

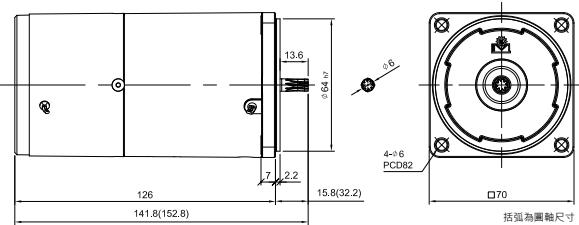

重量 Weight : 1.6kg ±5%

CM08 □ 25B

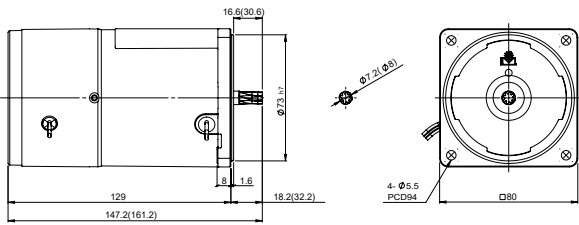

重量 Weight : 2kg ±5%

註：馬達減速機相關數據請參照「單相、三相之感應、可逆馬達」

減速機線圖 Gear Head

CG06B □ S □ 註：(*) 為 1/90~1/300 之尺寸

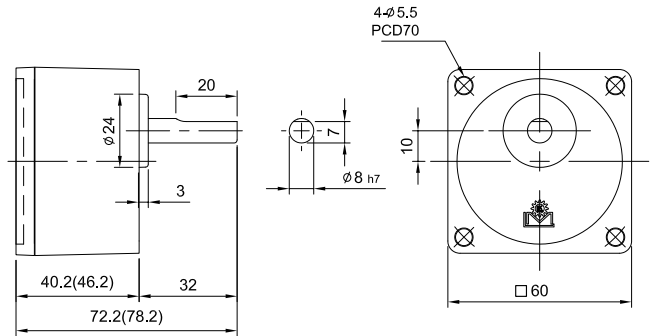

CG07B □ S □

註：(*) 為 1/90~1/240 之尺寸

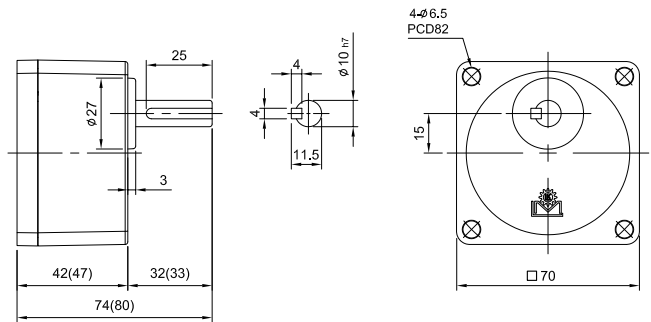

CG08B □ S □

註：(*) 為 1/90~1/300 之尺寸

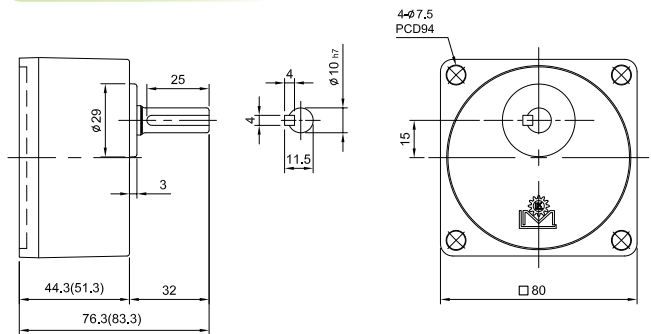

CG08B □ X

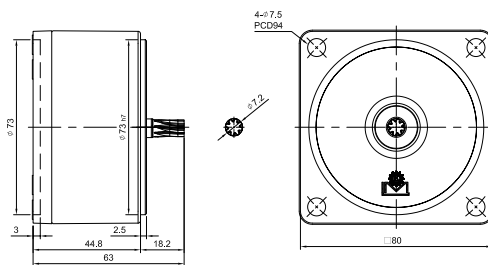

電磁剎車馬達機構
Electromagnetic Brake Motor Machinery

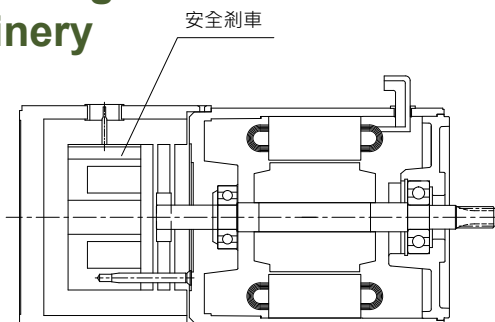

馬達線圖 Motor

CM09 □ 40B

註：IA (*) 為 IA 型相關尺寸

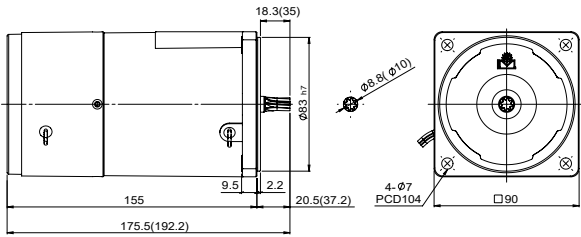

重量 Weight : 3kg ±5%

CM09 □ 40FB

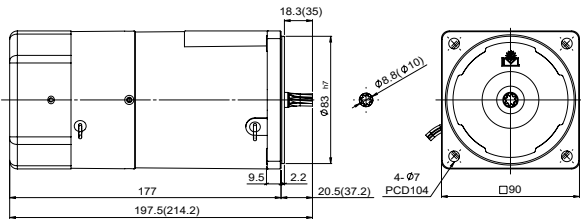

重量 Weight : 3.1kg ±5%

CM09 □ 40CFB

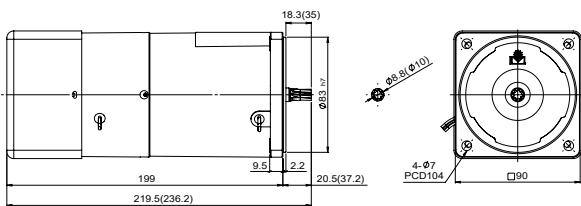

重量 Weight : 3.5kg ±5%

減速機線圖 Gear Head

CG09B □ S □

註：(*) 為 1/90~1/240 之尺寸

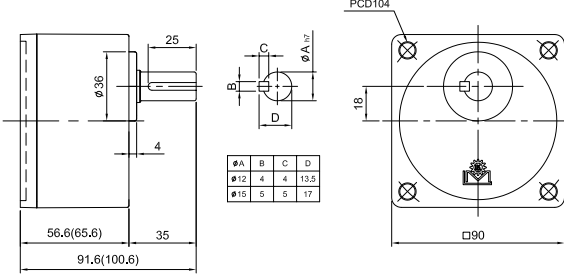

CG09B □ X

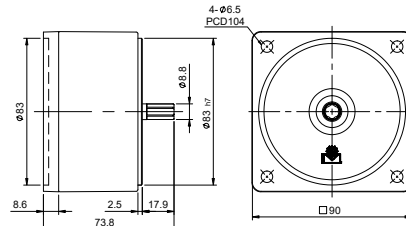

CGCU09B □ S □

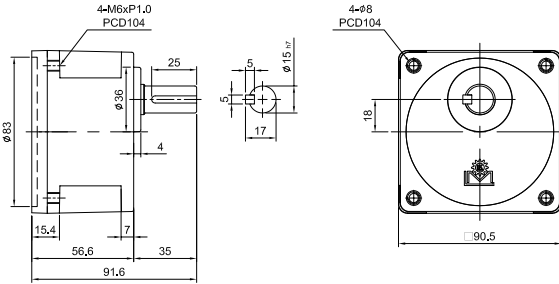

CGU09B □ S □

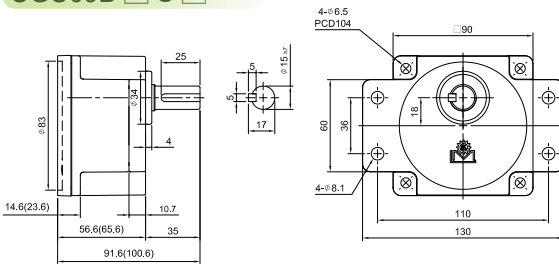

CGB09B □ H □

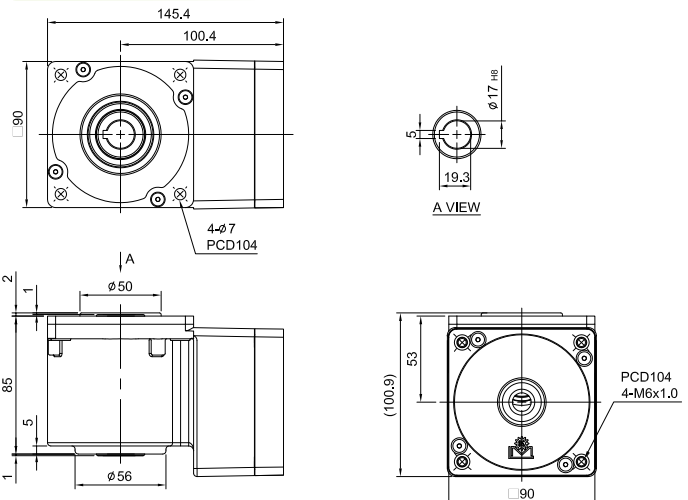

註：馬達減速機相關數據請參照「單相 . 三相之感應 . 可逆馬達」

馬達線圖 Motor

CM09 □ 60B 註：IA (*) 為 IA 型相關尺寸

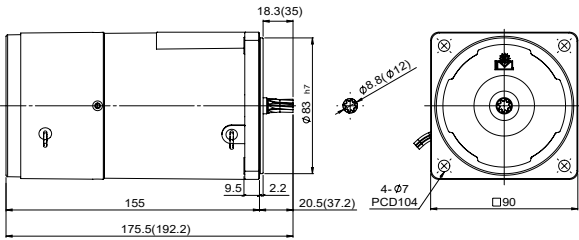

重量 Weight : 3kg ±5%

CM09 □ 60FB

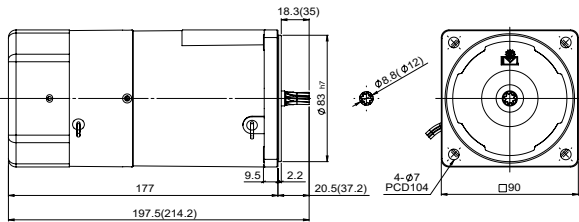

重量 Weight : 3.1kg ±5%

CM09 □ 60CFB

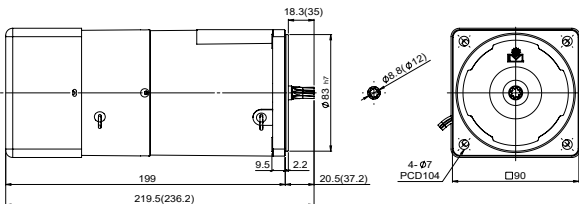

重量 Weight : 3.5kg ±5%

減速機線圖 Gear Head

CG09B □ S □ 註：(*) 為 1/90~1/240 之尺寸

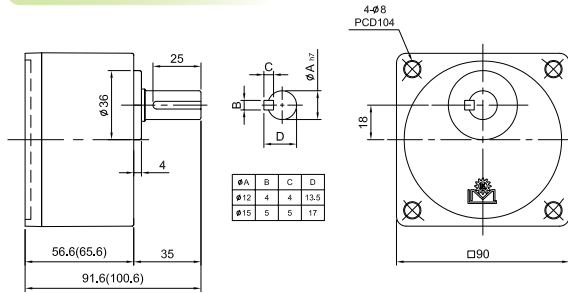

CG09B □ X

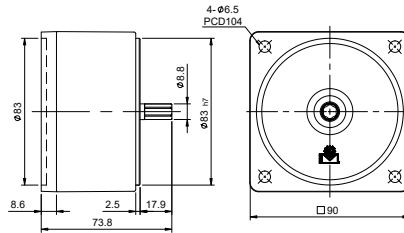

CGCU09B □ S □

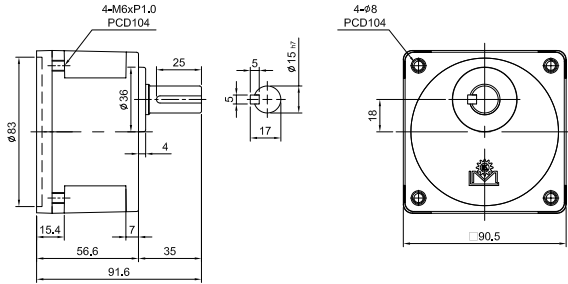

CGU09B □ S □

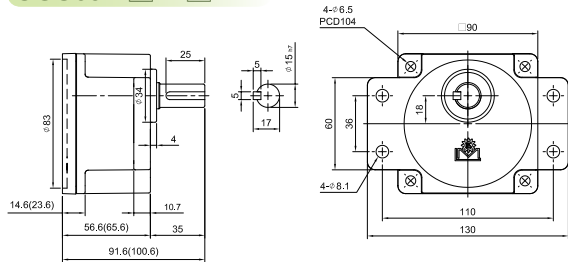

CGB09B □ H □

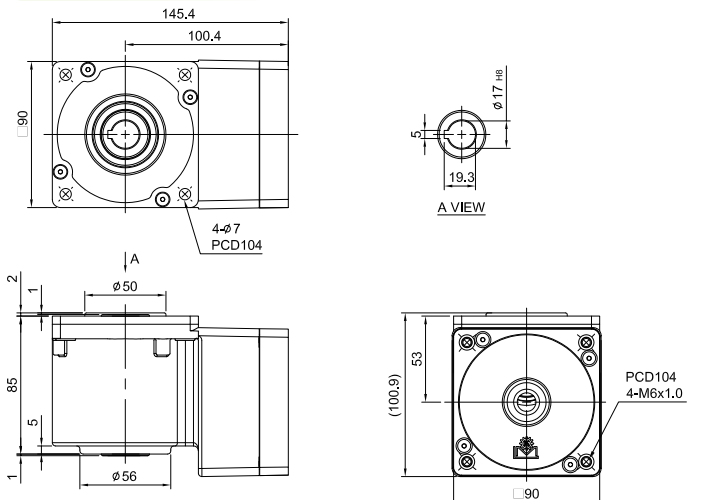

註：馬達減速機相關數據請參照「單相.三相之感應.可逆馬達」

馬達線圖 Motor

CM09 □ 90FB

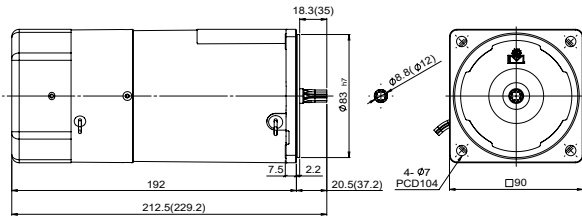

重量 Weight : 3kg ±5%

CM09 □ 90CFB

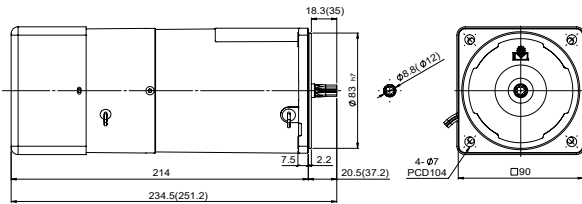

重量 Weight : 3.1kg ±5%

減速機線圖 Gear Head

CG09B □ S □

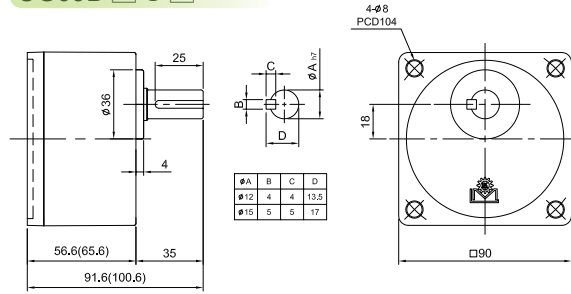

CG09B □ X

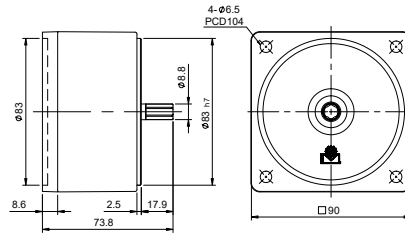

CGCU09B □ S □

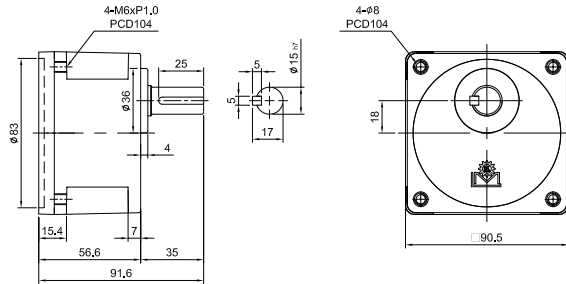

CGU09B □ S □

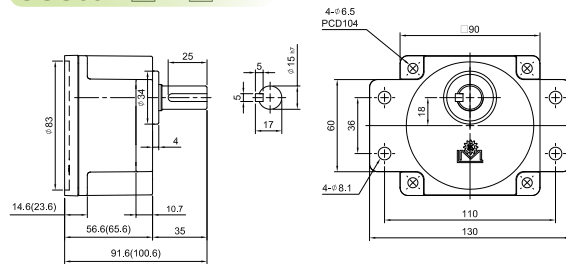

CGB09B □ H □

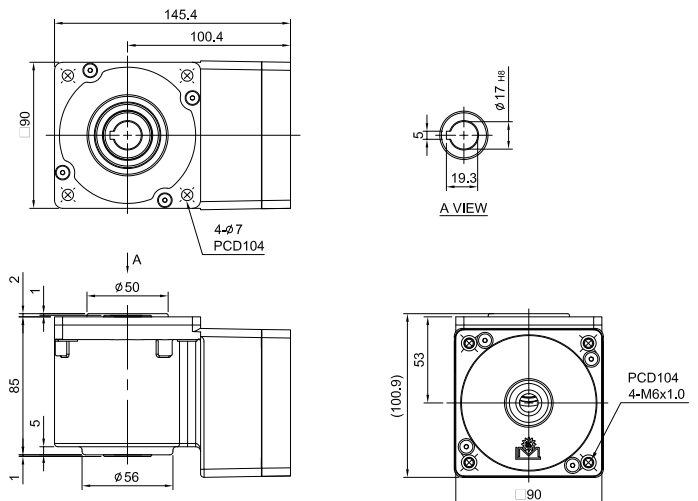

註：馬達減速機相關數據請參照「單相、三相之感應、可逆馬達」

MEMO

離合剎車器 Clutch Brake

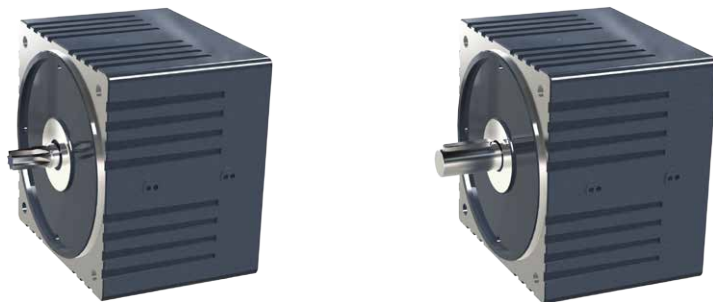

CB

Indication of Model Numbers

機種型號表示

CG	09	A	CB
機型 Type CG	型號 Model 09 : 90mm	出力軸 Output Shaft A : 圓柱軸 Cylindrical Shaft G : 螺旋齒 Helical Gear Shaft	離合剎車器 Clutch Brake

離合剎車馬達機構 Clutch Brake Motor Machinery

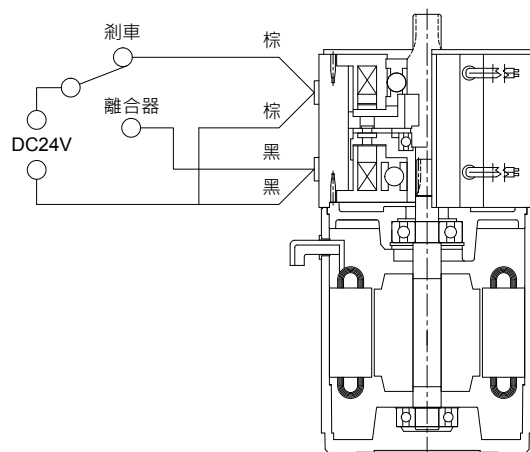

CG09GCB

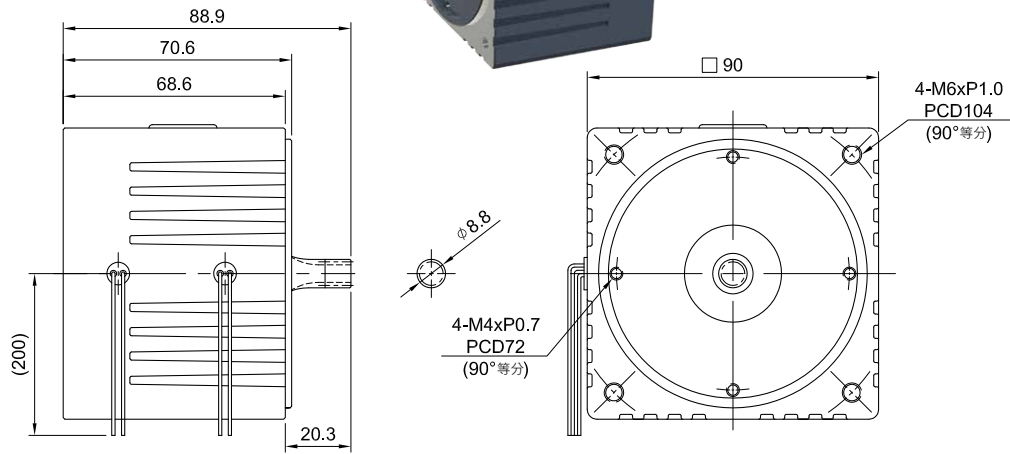

規格 Mordel No.	離合器 Clutch	剎車器 Brake	規格 Mordel No.	離合器 Clutch	剎車器 Brake
馬達出力 (W)	依馬達型號		吸引時間 (msec)	13	
額定電壓 DC (V)	24		轉矩建立時間 (msec)	—	
靜摩擦轉矩 (kgf-cm)	30	35	釋放時間 (msec)	13	
動摩擦轉矩 (kgf-cm)	28	33	動作頻率 (回 / 每分鐘)	每分鐘 60 次	
功率 (W)	6.72	5.76	導線 (UL1430, AWG22, L=300)	黑	棕
絕緣等級	E		來令片	非石棉	

CG09ACB

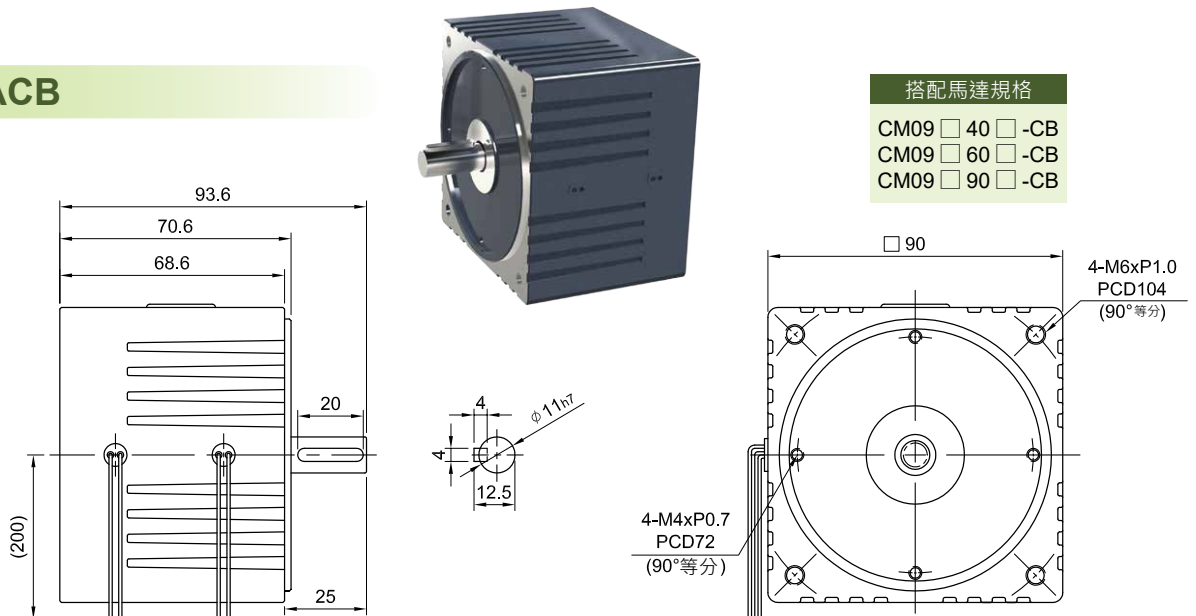

搭配馬達規格

CM09	40	-CB
CM09	60	-CB
CM09	90	-CB

規格 Mordel No.	離合器 Clutch	剎車器 Brake	規格 Mordel No.	離合器 Clutch	剎車器 Brake
馬達出力 (W)	依馬達型號		吸引時間 (msec)	13	
額定電壓 DC (V)	24		轉矩建立時間 (msec)	—	
靜摩擦轉矩 (kgf-cm)	30	35	釋放時間 (msec)	13	
動摩擦轉矩 (kgf-cm)	28	33	動作頻率 (回 / 每分鐘)	每分鐘 60 次	
功率 (W)	6.72	5.76	導線 (UL1430, AWG22, L=300)	黑	棕
絕緣等級	E		來令片	非石棉	

DC 有刷馬達 DC Motor



Indication of Model Numbers

機種型號表示

CM	09	D	G	60	V12	1800
機型 Type	型號 Model	馬達型式 Model Type	出力軸 Output Shaft	輸出功率 Output Power	電壓級數 Voltage	轉速 RPM
CM	06 : 60mm 07 : 70mm 08 : 80mm 09 : 90mm	D : 直流 Direct Current BL : 無刷 Brushless	A : 圓柱軸 Cylindrical Shaft G : 螺旋齒 Helical Gear Shaft		V12 : 12V V24 : 24V V90 : 90V V180 : 180V	1800RPM 3200RPM

MODEL : CM07DG

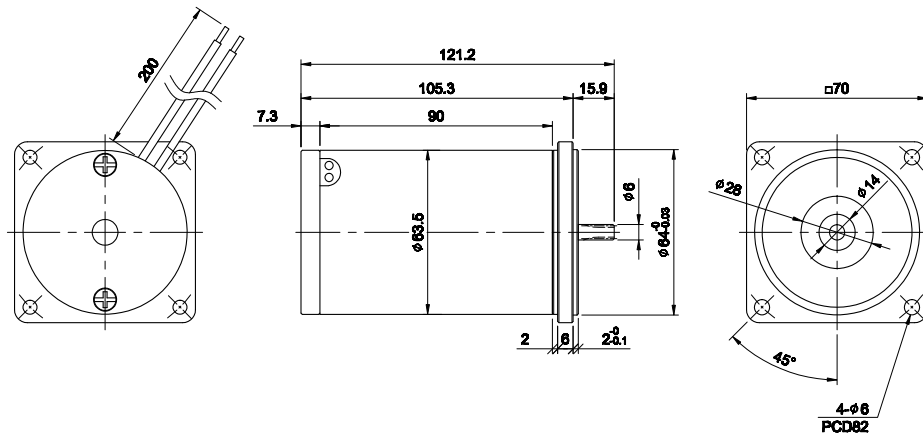

電壓 Voltage (V)	空載電流 No-Load Current (A)	額定電流 Rated Current (A)	轉速 Rotating Speed (RPM)	輸出功率 Output Power (W)	啟動轉矩 Start Torque (kgf·cm)	額定扭矩 Rated Torque (kgf·cm)	出口線 Export Line
12V	1A / 1.7A	3A / 5.1A	1800 / 3200	20 / 36	5	1	UL1015 / 12AWG
24V	0.4A / 0.7A	1.4A / 2.4A	1800 / 3200	20 / 36	5	1	UL1015 / 12AWG
90V	0.12A / 0.2A	0.3A / 0.5A	1800 / 3200	20 / 36	5	1	UL1015 / 14AWG

MODEL : CM08DG

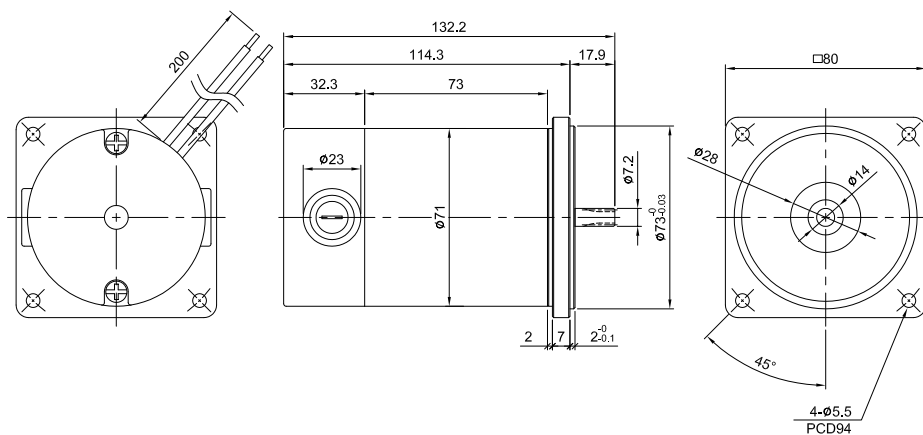

電壓 Voltage (V)	空載電流 No-Load Current (A)	額定電流 Rated Current (A)	轉速 Rotating Speed (RPM)	輸出功率 Output Power (W)	啟動轉矩 Start Torque (kgf·cm)	額定扭矩 Rated Torque (kgf·cm)	出口線 Export Line
12V	1.5A / 2.5A	4.2A / 7.1A	1800 / 3200	30 / 60	8	1.6	UL1015 / 12AWG
24V	0.4A / 0.7A	2.1A / 3.6A	1800 / 3200	30 / 60	8	1.6	UL1015 / 12AWG
90V	0.19A / 0.3A	0.58A / 1A	1800 / 3200	30 / 60	8	1.6	UL1015 / 14AWG

MODEL : CM09DG

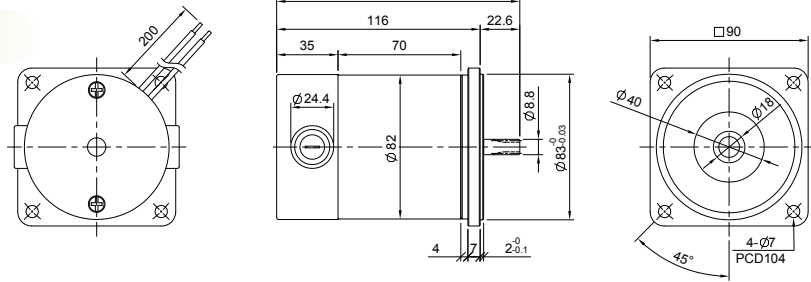

電壓 Voltage (V)	空載電流 No-Load Current (A)	額定電流 Rated Current (A)	轉速 Rotating Speed (RPM)	輸出功率 Output Power (W)	啟動轉矩 Start Torque (kgf-cm)	額定扭矩 Rated Torque (kgf-cm)	出口線 Export Line
12V	1.5A / 2.55A	5.5A / 9.3A	1800 / 3200	40 / 70	10	2	UL1015 / 12AWG
24V	0.75A / 1.2A	2.8A / 4.7A	1800 / 3200	40 / 70	10	2	UL1015 / 12AWG
90V	0.35A / 0.6A	0.85A / 1.4A	1800 / 3200	40 / 70	10	2	UL1015 / 14AWG

MODEL : CM09DG

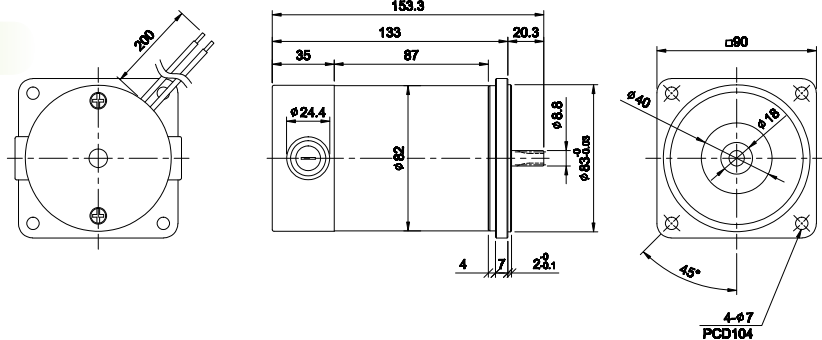

電壓 Voltage (V)	空載電流 No-Load Current (A)	額定電流 Rated Current (A)	轉速 Rotating Speed (RPM)	輸出功率 Output Power (W)	啟動轉矩 Start Torque (kgf-cm)	額定扭矩 Rated Torque (kgf-cm)	出口線 Export Line
12V	2.1A / 3.3A	8.6A / 14.6A	1800 / 3200	65 / 120	23	4.6	UL1015 / 12AWG
24V	0.7A / 1.2A	5.1A / 8.7A	1800 / 3200	65 / 120	23	4.6	UL1015 / 12AWG
90V	0.11A / 0.18A	1.1A / 1.8A	1800 / 3200	65 / 120	23	4.6	UL1015 / 14AWG
180V	0.06A / 0.1A	0.5A / 0.85A	1800 / 3200	65 / 120	23	4.6	UL1015 / 14AWG

MODEL : CM09DG

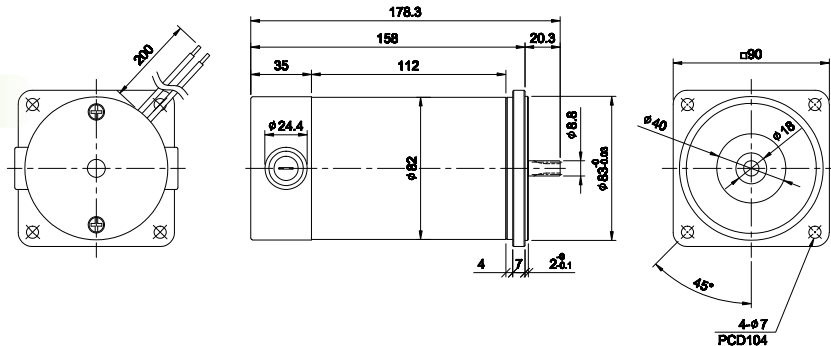

電壓 Voltage (V)	空載電流 No-Load Current (A)	額定電流 Rated Current (A)	轉速 Rotating Speed (RPM)	輸出功率 Output Power (W)	啟動轉矩 Start Torque (kgf-cm)	額定扭矩 Rated Torque (kgf-cm)	出口線 Export Line
12V	2.2A / 3.7A	11.4A / 19.4A	1800 / 3200	100 / 200	32	6.5	UL1015 / 12AWG
24V	1.2A / 2A	5.7A / 9.7A	1800 / 3200	100 / 200	32	6.5	UL1015 / 12AWG
90V	0.25A / 0.43A	1.5A / 2.6A	1800 / 3200	100 / 200	32	6.5	UL1015 / 14AWG
180V	0.1A / 0.2A	0.82A / 2.6A	1800 / 3200	100 / 200	32	6.5	UL1015 / 14AWG

■ 微型馬達系列選配品 Accessories for Gearmotor

L 型腳座 L Type Base Kits

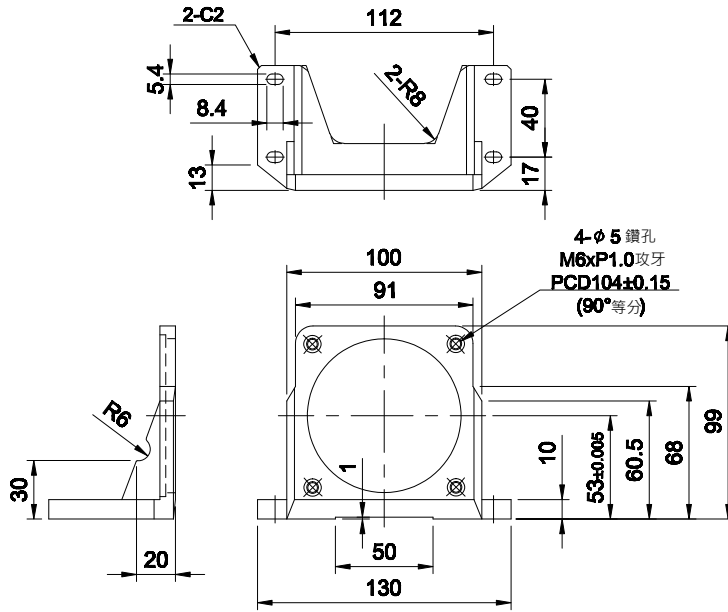

平行式中空軸減速機

Hollow Shaft Gear Reducer



Indication of Model Numbers

機種型號表示

COG	09	B	20	H	20
機型 Type	型號 Model	軸承型式 Bearing	減速比 Ratio	出力軸 Output Shaft	出力軸孔徑 Output Bore
COG	09 : 90mm	B : 滾珠軸承 Ball bearing	10 20 25 33 50	H : 出力中空軸 Hollow Output Shaft	20

節省空間 Save Space

- ◆ 未使用連結零件，直接連結驅動軸，實現了裝置的節省空間化。
The connecting parts are not used, and the drive shaft is directly connected, thereby realizing space saving of the device.

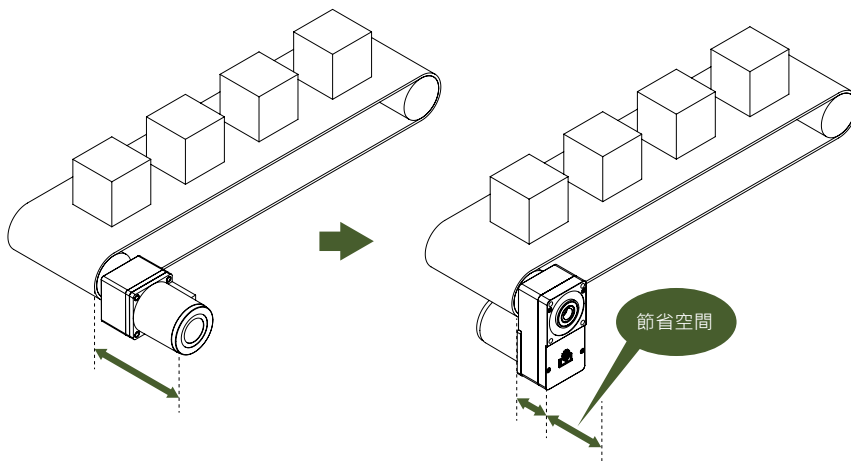

MODEL : COG09

中空軸齒輪減速機 Hollow Shaft Gear Reducer
RATIO : 10、20、25、33、50

註：馬達、速度控制器另購。
Note: Motor & speed controller is optional.

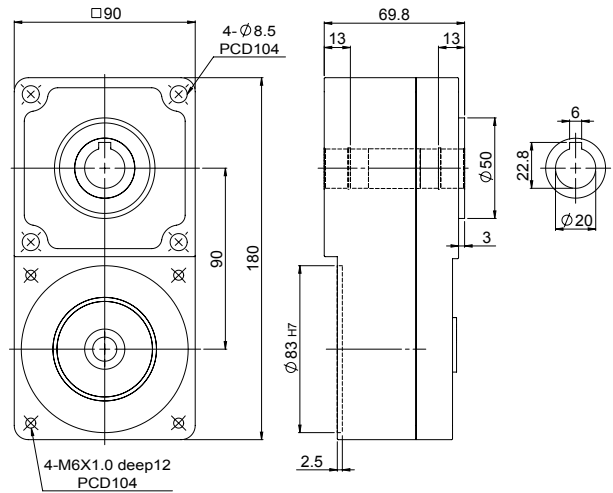

■ 平行式中空軸減速機之容許轉矩 Permissible Torque of Hollow Shaft Gear Reducer

減速機型號 Reducer Mode	馬達輸出功率 Motor Output Power	減速比 Ratio	20	33	50	62
COG09B	100W	轉速 Rated Speed (RPM)	3,000	3,000	3,000	3,000
		額定轉矩 Rated Torque (Nm)	7	11.5	17.5	21.7
	200W	轉速 Rated Speed (RPM)	3,000	3,000	3,000	3,000
		額定轉矩 Rated Torque (Nm)	9.3	15.4	23.3	28.9
	400W	轉速 Rated Speed (RPM)	3,000	3,000	3,000	3,000
		額定轉矩 Rated Torque (Nm)	16	26.4	40.1	49.7

■ 平行式中空軸減速機容許懸吊載重、容許推力載重

Permissible Overhung Load & Permissible Thrust Load of Hollow Shaft Gear Reducer

減速機型號 Reducer Mode	減速比 Ratio	轉速 Rated Speed (RPM)	容許懸吊載重 Permissible Overhung Load		容許推力載重 Permissible Thrust Load
			10 mm	20 mm	
COG09B	10、20、25、33、50	3,000	1,300N	1,110N	500N
			1,500N	1,280N	

強力型齒輪減速機 Powerful Reducer



Indication of Model Numbers

機種型號表示

CGS	09	B	5	S18
機型 Type CGS	型號 Model 09 : 90mm	軸承型式 Bearing B : 滾珠軸承 Ball bearing	減速比 Ratio 5 10 20 25 30 100	出力軸 Output Shaft S : 實心軸 Solid Output Shaft Ø18

MODEL : CGS09B □ S18

強力型齒輪減速機 Powerful Reducer
RATIO : 5, 10, 20, 25, 30, 100

註：馬達、速度控制器另購。
Note: Motor & speed controller is optional.

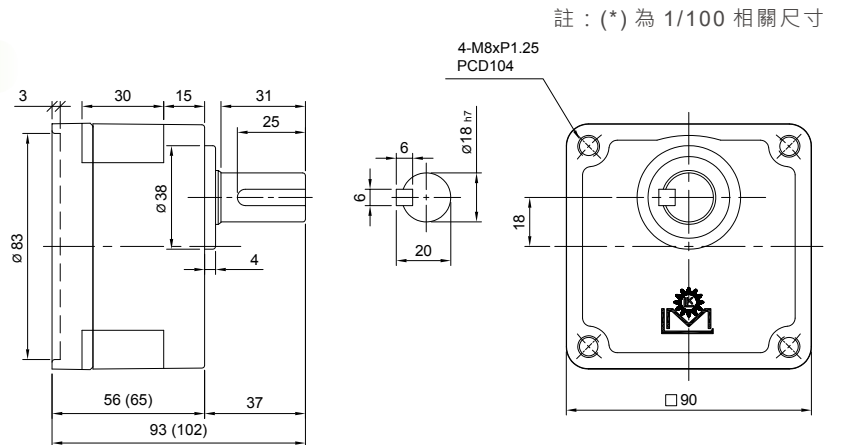

■ 強力型齒輪減速機之容許轉矩 Permissible Torque of Hollow Shaft Gear Reducer

減速機型號 Reducer Mode	馬達輸出功率 Motor Output Power	減速比 Ratio	5	10	20	25	30	100
CGS09B	100W	轉速 Rated Speed (RPM)	3,000	3,000	3,000	3,000	3,000	3,000
		額定轉矩 Rated Torque (Nm)	1.1	2.3	4.4	5.8	7	22.4
	200W	轉速 Rated Speed (RPM)	3,000	3,000	3,000	3,000	3,000	3,000
		額定轉矩 Rated Torque (Nm)	2.2	4.5	9.1	11.4	13.7	25

MEMO

直線減速機 Linear Reducer

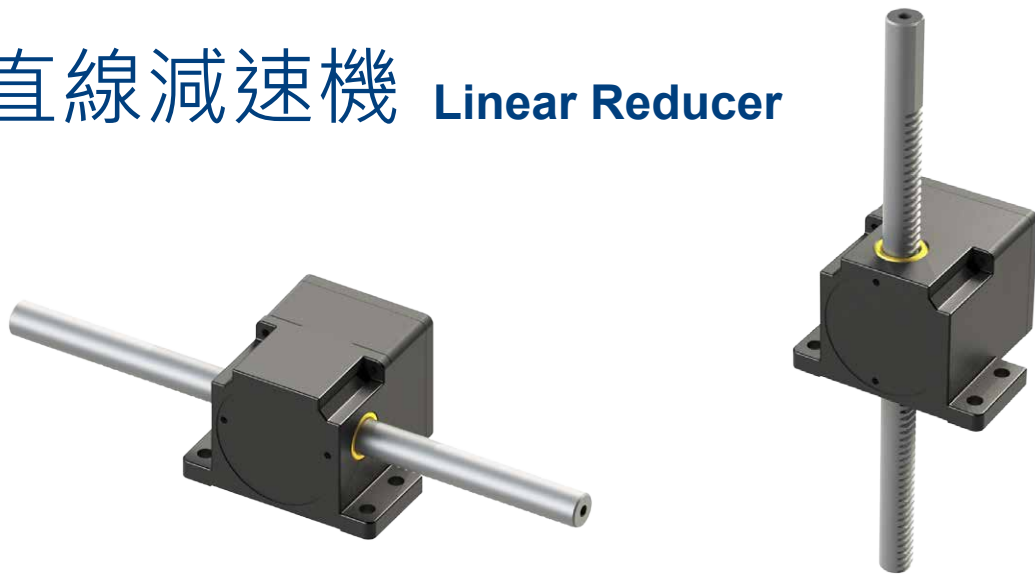

Indication of Model Numbers

機種型號表示

CGR	06	H	50	10	1
機型 Type	型號 Model	齒條移動方向 Rack Moving Direction	速比 Ratio	齒條速度 Rack Speed	齒條有效行程 Rack Effective Stroke
CGR	06 : 60mm 08 : 80mm 09 : 90mm	H : 臥式 Horizontal V : 立式 Vertical		齒條基本速度 以馬達轉數 1800r/min 計 算所得數值。	1 : 100mm 2 : 200mm 3 : 300mm 4 : 400mm 5 : 500mm

直線減速機特性 Characteristic of Linear Reducer

直線減速機之特性中，較重要的地方為

- 齒條速度
- 載重
- 保持力

以上 3 點

齒條速度

基本速度乃是根據馬達的同步轉數 (50Hz:1500r/min) 為基準來計算。實際上馬達轉數會依負載的大小而變化。與直線減速機搭配的馬達轉數可依下列的公式計算。

$$V = N_s \times \frac{1}{60} \times \frac{1}{i} \times \pi D_p$$

V : 齒條的移動速度 (mm/s)

N_s : 所搭配的馬達轉速 (r/min)

i : 直線減速機的減速機構之減速比→下表

D_p : 小齒輪的齒距直徑 (mm) → 下表

載重

與直線減速機搭配的馬達轉矩可由下列式子算出。

$$W = T_m \times i \times \eta^1 \times \frac{2}{D_p} \times 10 \times \eta^2$$

T_m : 馬達的轉矩 (kgf-cm)

W : 載重 (kg)

i : 直線減速機的減速機構之減速比→下表

η^1 : 不同減速比的傳達效率→下表

D_p : 小齒輪的齒距直徑 (mm) → 下表

η^2 : 齒條與小齒輪的傳動效率 (=0.9)

馬達轉矩請使用馬達起動轉矩或額定轉矩中數值最小的一方。

型號 Model	減速比 Ratio																		小齒輪齒距直徑 Pitch diameter of small gear D_p (mm)	
	5	6	7.5	9	12.5	15	18	25	30	36	50	60	75	90	100	120	150	180		200
CGR06 □	73%											66%						21		
CGR08 □	73%											66%						28		
CGR09 □	73%											66%						29		

特性表中的推力及計算出的載重數值為齒條水平方向運轉的數值。上下運動的載重則為特性表中的數值減去齒條重量 (請參考外形圖) 所得的數值。

保持力

與直線減速機組合時，可利用馬達的保持力依下式算出。

$$F_B = T_B \times i \times \frac{2}{D_p} \times 10$$

F_B : 保持力 (kg)

T_B : 馬達的保持轉矩 (kgf-cm)

i : 直線減速機之減速機構的減速比→上表

D_p : 小齒輪的齒距直徑 (mm) → 上表

特性表中的保持力及計算求得的保持力的數值，都是齒條設置在水平方向時的數值。設置在上下方向的話必需將特性表中的數值減去齒條的重量 (請參考外形圖)。

Among the characteristics of linear reducers, the more important ones are

- Rack Speed
- Load
- Holding

Above 3 points

Rack Speed

$$V = N_s \times \frac{1}{60} \times \frac{1}{i} \times \pi D_p$$

V : Rack Moving Speed (mm/s)

N_s : Motor Speed (r/min)

i : Ratio of Reducers Gear Diameter → The following table

D_p : Pitch diameter of small gear (mm) → The following table

Load

$$W = T_m \times i \times \eta^1 \times \frac{2}{D_p} \times 10 \times \eta^2$$

T_m : Motor Torque (kgf-cm)

W : Load (kg)

i : Ratio of Reducers Gear Diameter → The following table

η^1 : Efficiency of different reduction ratios → The following table

D_p : Pitch diameter of small gear (mm) → The following table

η^2 : Rack & Gear Efficiency (=0.9)

Holding

$$F_B = T_B \times i \times \frac{2}{D_p} \times 10$$

F_B : Holding (kg)

T_B : Motor Holding Torque (kgf-cm)

i : Ratio of Reducers Gear Diameter → Above table

D_p : Pitch diameter of small gear (mm) → Above table

注意事項 Precautions

- ◆ 懸吊載重請保持在容許數值以下使用
O.H.L Allowable Value

unit: kg

齒條行程 Rack Stroke (mm)	06#	08#	09#
100	5.5	12	13
200	4	9	10
300	3	7	8
400	2.5	6	6
500	2	5	5

主要規格 Main Specifications

直線減速機機型 Linear Reducer Type	基本速度 Basic Speed (mm/s)	最大載重 ※ Maxi. Load 50Hz / 60Hz (kg)	齒條有效行程 Rack Effective Stroke (mm)
CGR06	50	4.6 / 3.6	100、200、300、400、500
	25	10.1 / 7.8	
	10	22 / 22	
CGR08	45	35 / 26	100、200、300、400、500
	20	65 / 49	
	10	72 / 72	
CGR09	45	63 / 57	100、200、300、400、500
	20	92	
	10	92	

- ◆ 基本速度是以馬達的同步轉速 (60Hz:1800r/min) 為基準計算所得的標準值。實際的速度會因負載的大小及電源頻率而改變。
- ◆ 最大載重為齒輪平行移動時的所得值。上下方向動作時需減去齒條本身重量。
- ※ 最大載重為連結可逆馬達時的計算值
- ◆ The speed is calculated based on the synchronous speed of the motor. Actual speed will change due to load and power frequency.
- ◆ The value when the rack moves in parallel is the maximum load reduce the weight of the rack itself when moving up and down.
- ※ The maximum load is the calculated value when connecting the reversible motor.

用途和推薦可搭配的馬達 Use and Recommended Motor

用途 Use	適用馬達 Applicable Motor	06#	08#	09#
一定速度 Certain Speed	可逆馬達 Reversible Motor	CM06RG6SA CM06RG6SB	CM08RG25SA CM08RG25SB	CM09RG40~90SA CM09RG40~90SB
可調速 Speed Variable	組合型控制器搭配馬達 Assembly Type Controller with Motor 分離型控制器搭配馬達 Separated Style Controller with Motor	SCU SCS		
保持位置時 Keep Position	附電磁剎車馬達 Electromagnetic Brake Motor	CM06IG6SAB CM06IG6SBB	CM08IG25SAB CM08IG25SAB	CM09IG40~90SAB CM09IG40~90SBB

MODEL : CGR06H

臥式直線減速機 Horizontal Type Linear Reducer

RATIO : 5,6,7.5,9,12.5,15,18,25,30,36,50,60,75

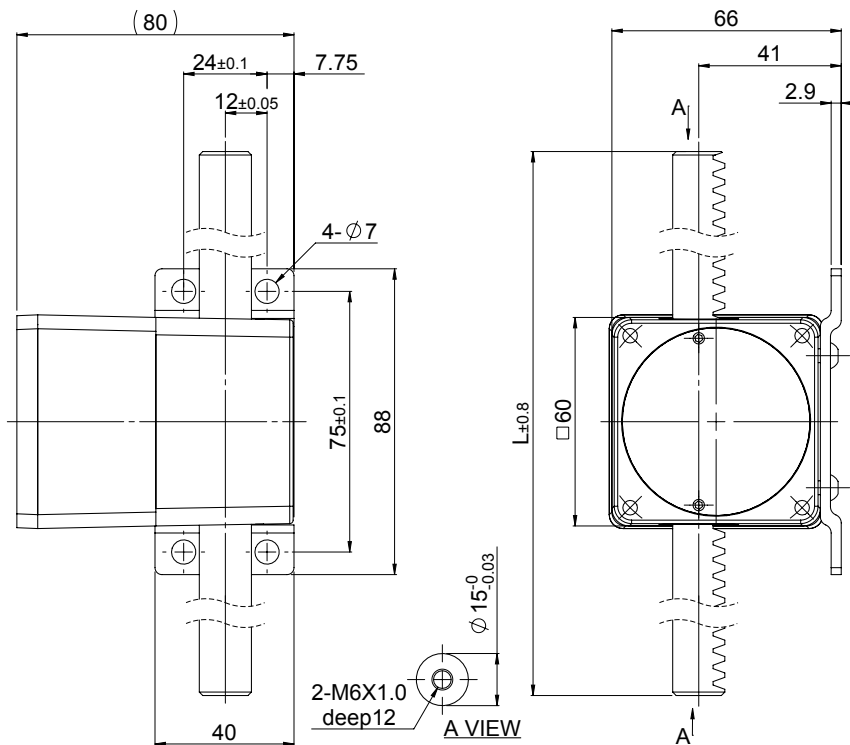
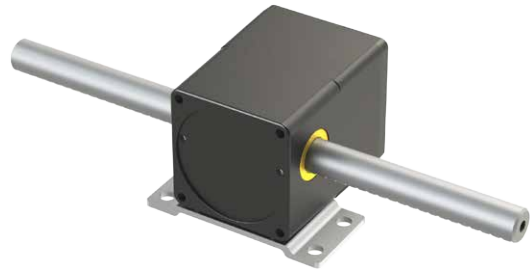

最大載重 Max. Load

20kg

最大載重 20kg。但是依基本速度及組合的馬達不同而有所變動。
Max. Load 20kg. Will vary due to speed and motor.

規格 Specification

unit: mm

基本速度 Basic Speed	品名 Model	齒條行程 Rack Stroke	行程 Stroke (mm)	齒條總長 L Rack Length (mm)	重量 (包含齒條重量) Weight (kg) (Includes Rack Weight)	齒條重量 Rack Weight (kg)	最大懸吊載重 Max. O.H.L. (kg)
10mm/s	CGR06H10 <input type="checkbox"/>	100mm	120	200	0.9	0.2	5.5
	CGR06V10 <input type="checkbox"/>	200mm	220	300	1	0.3	4
25mm/s	CGR06H25 <input type="checkbox"/>	300mm	320	400	1.1	0.4	3
	CGR06V25 <input type="checkbox"/>	400mm	420	500	1.2	0.5	2.5
50mm/s	CGR06H50 <input type="checkbox"/>	500mm	520	600	1.3	0.6	2
	CGR06V50 <input type="checkbox"/>						

基本速度值是以馬達的同步轉數 (60Hz:1800r/min) 為基準計算所得的標準值。實際的速度則視負載的大小及電源的頻率而改變。

中表示齒條的行程。

The speed is calculated based on the synchronous speed of the motor. Actual speed will change due to load and power frequency.

Indicate rack stroke.

MODEL : CGR06V

立式直線減速機 Vertical Type Linear Reducer
 RATIO : 5,6,7.5,9,12.5,15,18,25,30,36,50,60,75

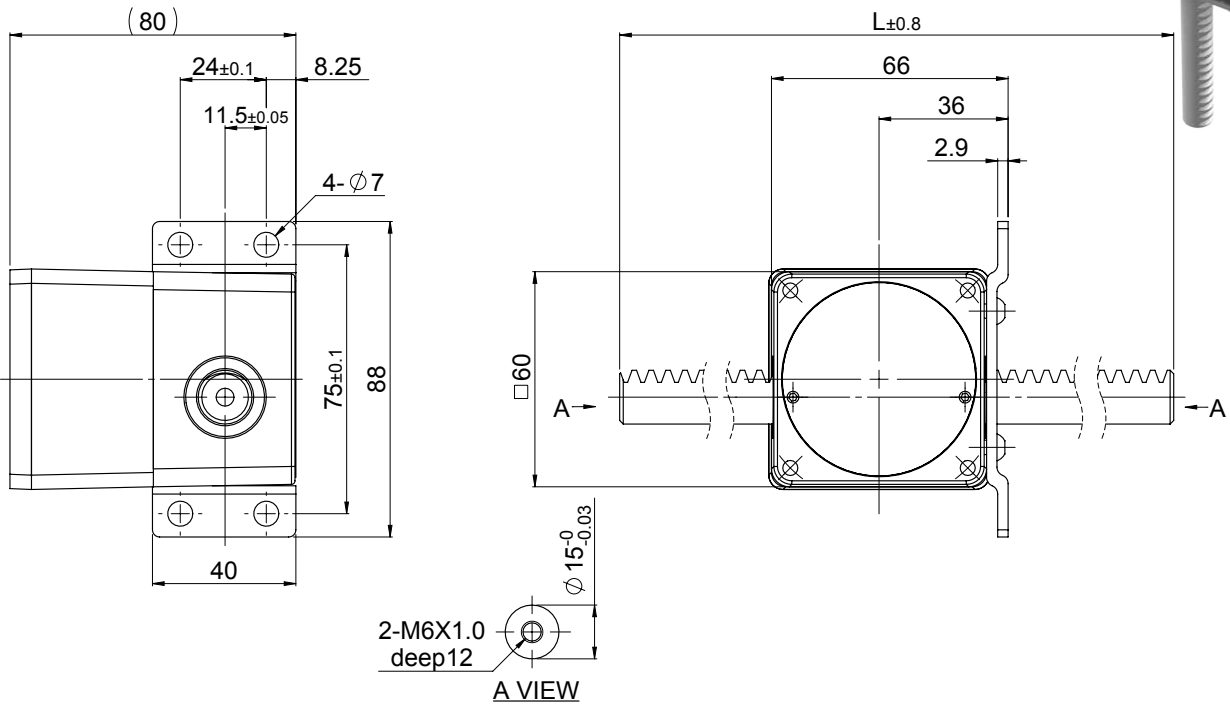

CGR
60
 mm
 6W

最大載重 Max. Load
20kg

最大載重 20kg。但是依基本速度及組合的馬達不同而有所變動。
 Max. Load 20kg. Will vary due to speed and motor.

規格 Specification

unit: mm

基本速度 Basic Speed	品名 Model	齒條行程 Rack Stroke	行程 Stroke (mm)	齒條總長 L Rack Length (mm)	重量 (包含齒條重量) Weight (kg) (Includes Rack Weight)	齒條重量 Rack Weight (kg)	最大懸吊載重 Max. O.H.L. (kg)
10mm/s	CGR06H10 <input type="checkbox"/>	100mm	120	200	0.9	0.2	5.5
	CGR06V10 <input type="checkbox"/>	200mm	220	300	1	0.3	4
25mm/s	CGR06H25 <input type="checkbox"/>	300mm	320	400	1.1	0.4	3
	CGR06V25 <input type="checkbox"/>	400mm	420	500	1.2	0.5	2.5
50mm/s	CGR06H50 <input type="checkbox"/>	500mm	520	600	1.3	0.6	2
	CGR06V50 <input type="checkbox"/>						

基本速度值是以馬達的同步轉數 (60Hz:1800r/min) 為基準計算所得的標準值。實際的速度則視負載的大小及電源的頻率而改變。

中表示齒條的行程。

The speed is calculated based on the synchronous speed of the motor. Actual speed will change due to load and power frequency.

Indicate rack stroke.

MODEL : CGR08H

臥式直線減速機 Horizontal Type Linear Reducer
RATIO : 5,6,7.5,9,12.5,15,18,25,30,36,50,60,75

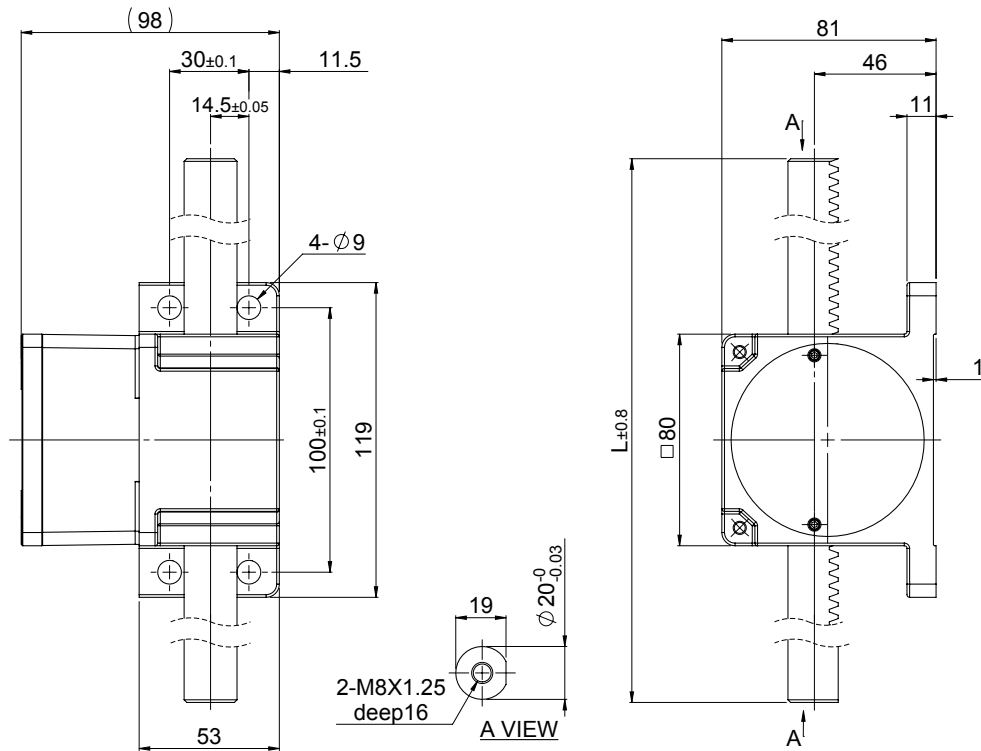
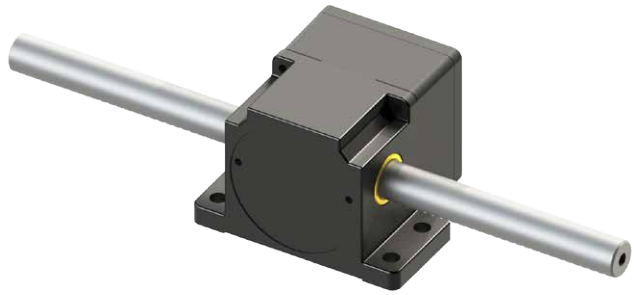

最大載重 Max. Load
70kg

最大載重 70kg。但是依基本速度及組合的馬達不同而有所變動。
Max. Load 70kg. Will vary due to speed and motor.

規格 Specification

unit: mm

基本速度 Basic Speed	品名 Model	齒條行程 Rack Stroke	行程 Stroke (mm)	齒條總長 L Rack Length (mm)	重量 (包含齒條重量) Weight (kg) (Includes Rack Weight)	齒條重量 Rack Weight (kg)	最大懸吊載重 Max. O.H.L. (kg)
10mm/s	CGR08H10 <input type="checkbox"/>	100mm	100	200	1.6	0.4	12
	CGR08V10 <input type="checkbox"/>	200mm	200	300	1.8	0.7	9
20mm/s	CGR08H20 <input type="checkbox"/>	300mm	300	400	2	0.9	7
	CGR08V20 <input type="checkbox"/>	400mm	400	500	2.2	1.1	6
45mm/s	CGR08H45 <input type="checkbox"/>	500mm	500	600	2.4	1.3	5
	CGR08V45 <input type="checkbox"/>						

基本速度值是以馬達的同步轉數 (60Hz:1800r/min) 為基準計算所得的標準值。實際的速度則視負載的大小及電源的頻率而改變。

中表示齒條的行程。

The speed is calculated based on the synchronous speed of the motor. Actual speed will change due to load and power frequency.

Indicate rack stroke.



MODEL : CGR08V

立式直線減速機 Vertical Type Linear Reducer
RATIO : 5,6,7.5,9,12.5,15,18,25,30,36,50,60,75

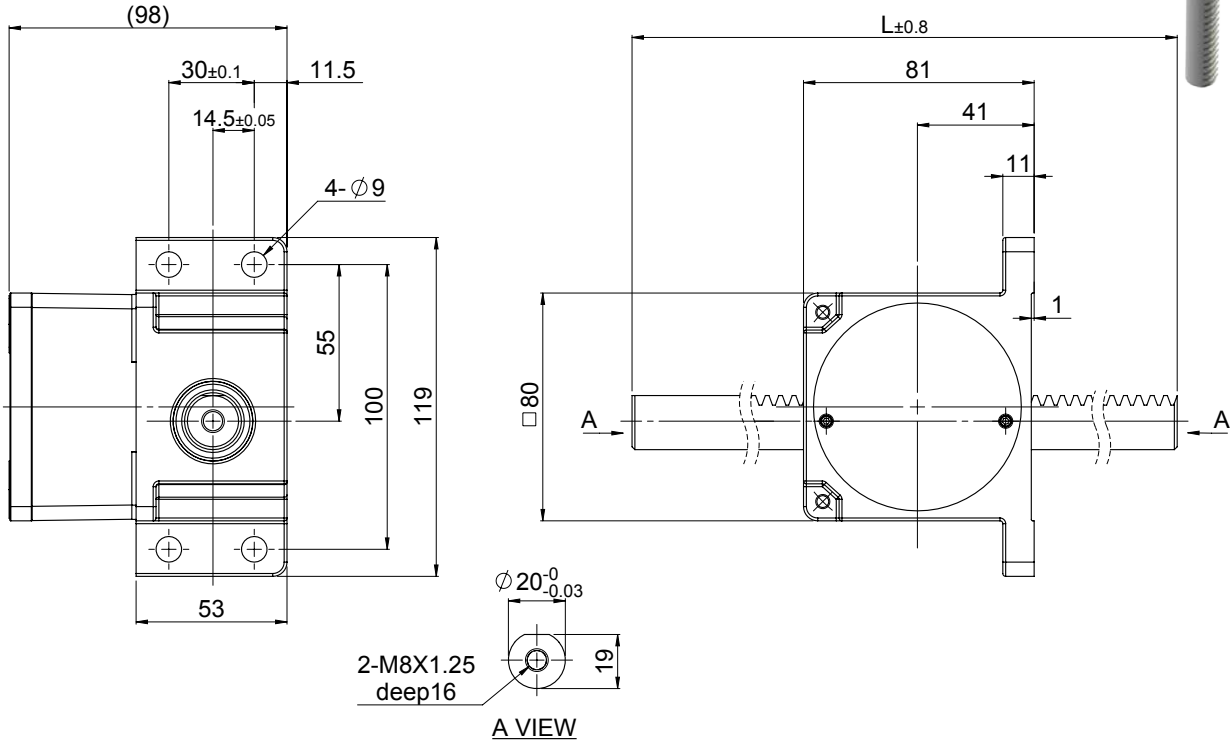

最大載重 Max. Load
70kg

最大載重 70kg。但是依基本速度及組合的馬達不同而有所變動。
Max. Load 70kg. Will vary due to speed and motor.

規格 Specification

unit: mm

基本速度 Basic Speed	品名 Model	齒條行程 Rack Stroke	行程 Stroke (mm)	齒條總長 L Rack Length (mm)	重量 (包含齒條重量) Weight (kg) (Includes Rack Weight)	齒條重量 Rack Weight (kg)	最大懸吊載重 Max. O.H.L. (kg)
10mm/s	CGR08H10 <input type="checkbox"/>	100mm	100	200	1.6	0.4	12
	CGR08V10 <input type="checkbox"/>	200mm	200	300	1.8	0.7	9
20mm/s	CGR08H20 <input type="checkbox"/>	300mm	300	400	2	0.9	7
	CGR08V20 <input type="checkbox"/>	400mm	400	500	2.2	1.1	6
45mm/s	CGR08H45 <input type="checkbox"/>	500mm	500	600	2.4	1.3	5
	CGR08V45 <input type="checkbox"/>						

基本速度值是以馬達的同步轉數 (60Hz:1800r/min) 為基準計算所得的標準值。實際的速度則視負載的大小及電源的頻率而改變。

中表示齒條的行程。

The speed is calculated based on the synchronous speed of the motor. Actual speed will change due to load and power frequency.

Indicate rack stroke.

MODEL : CGR09H

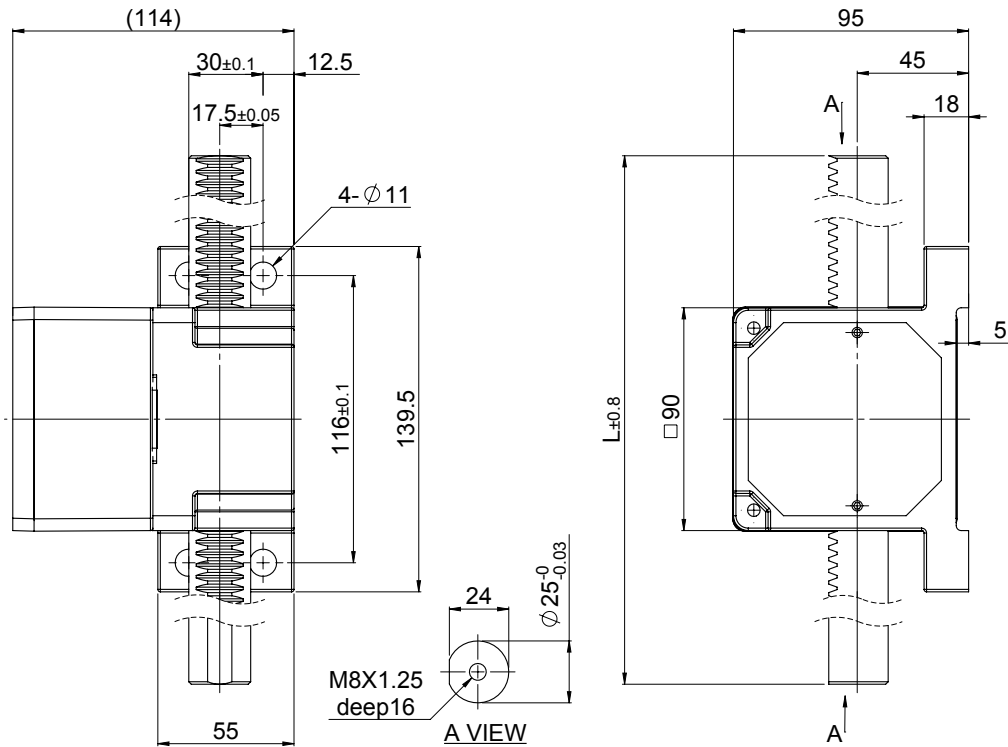
 臥式直線減速機 Horizontal Linear Reducer
 RATIO : 5,6,7.5,9,12.5,15,18,25,30,36,50,60,75

最大載重 Max. Load
90kg

 最大載重 90kg。但是依基本速度及組合的馬達不同而有所變動。
 Max. Load 90kg. Will vary due to speed and motor.

規格 Specification

unit: mm

基本速度 Basic Speed	品名 Model	齒條行程 Rack Stroke	行程 Stroke (mm)	齒條總長 L Rack Length (mm)	重量 (包含齒條重量) Weight (kg) (Includes Rack Weight)	齒條重量 Rack Weight (kg)	最大懸吊載重 Max. O.H.L. (kg)
10mm/s	CGR09H10 <input type="checkbox"/>	100mm	100	200	3.2	0.9	13
	CGR09V10 <input type="checkbox"/>	200mm	200	300	3.6	1.2	10
20mm/s	CGR09H20 <input type="checkbox"/>	300mm	300	400	3.9	1.6	8
	CGR09V20 <input type="checkbox"/>	400mm	400	500	4.3	1.9	6
45mm/s	CGR09H45 <input type="checkbox"/>	500mm	500	600	4.6	2.3	5
	CGR09V45 <input type="checkbox"/>						

基本速度值是以馬達的同步轉數 (60Hz:1800r/min) 為基準計算所得的標準值。實際的速度則視負載的大小及電源的頻率而改變。

 中表示齒條的行程。

The speed is calculated based on the synchronous speed of the motor. Actual speed will change due to load and power frequency.

 Indicate rack stroke.



MODEL : CGR09V

立式直線減速機 Vertical Type Linear Reducer
RATIO : 5,6,7.5,9,12.5,15,18,25,30,36,50,60,75

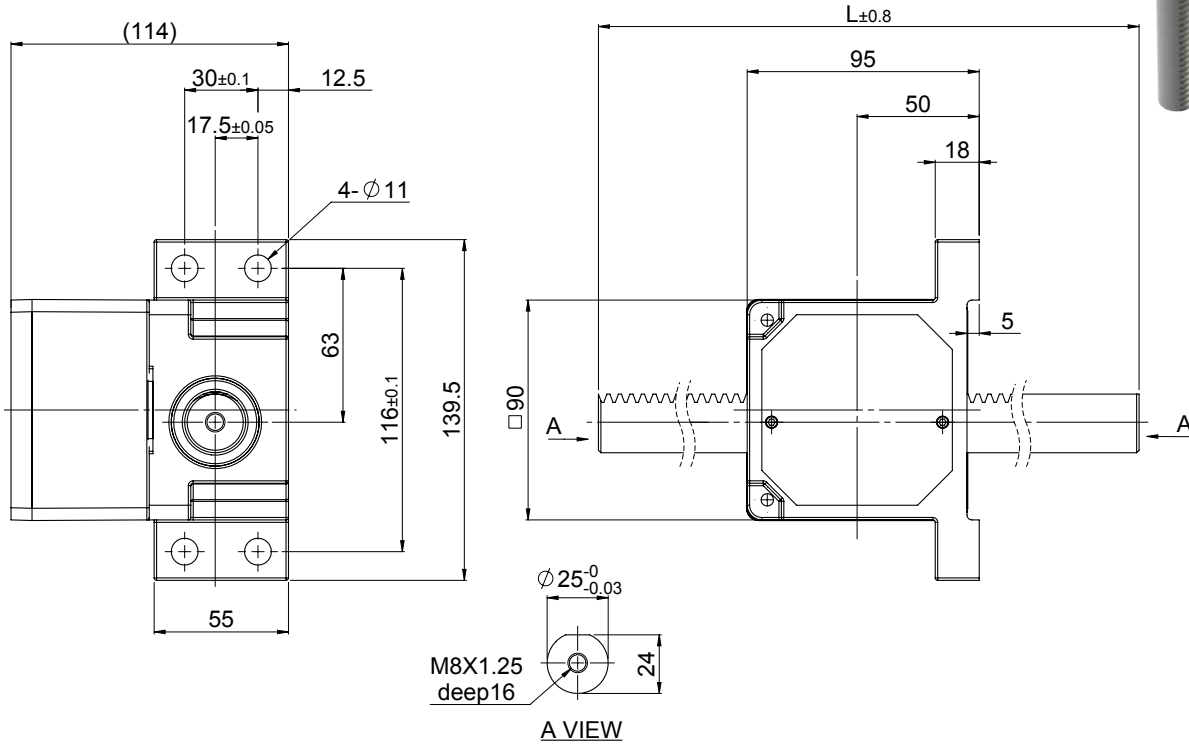

最大載重 Max. Load
90kg

最大載重 90kg。但是依基本速度及組合的馬達不同而有所變動。
Max. Load 90kg. Will vary due to speed and motor.

規格 Specification

unit: mm

基本速度 Basic Speed	品名 Model	齒條行程 Rack Stroke	行程 Stroke (mm)	齒條總長 L Rack Length (mm)	重量 (包含齒條重量) Weight (kg) (Includes Rack Weight)	齒條重量 Rack Weight (kg)	最大懸吊載重 Max. O.H.L. (kg)
10mm/s	CGR09H10 <input type="checkbox"/>	100mm	100	200	3.2	0.9	13
	CGR09V10 <input type="checkbox"/>	200mm	200	300	3.6	1.2	10
20mm/s	CGR09H20 <input type="checkbox"/>	300mm	300	400	3.9	1.6	8
	CGR09V20 <input type="checkbox"/>	400mm	400	500	4.3	1.9	6
45mm/s	CGR09H45 <input type="checkbox"/>	500mm	500	600	4.6	2.3	5
	CGR09V45 <input type="checkbox"/>						

基本速度值是以馬達的同步轉數 (60Hz:1800r/min) 為基準計算所得的標準值。實際的速度則視負載的大小及電源的頻率而改變。

中表示齒條的行程。

The speed is calculated based on the synchronous speed of the motor. Actual speed will change due to load and power frequency.

Indicate rack stroke.

鋁合金蝸輪減速機

Aluminum Alloy Worm Reducer



Indication of Model Numbers

機種型號表示

NECM	50	10	L	90	SA	T
機型 Type	型號 Model	速比 Ratio	軸向 Direction	輸出功率 Output Power	電壓級數 Voltage	附件 Accessory
NECM	30			40 : 40W	SA : 1Ø 110V 4P	T: 鋁端子盒
NEOCM	40			60 : 60W	SB : 1Ø 220V 4P	Aluminum
NEHCM	50			90 : 90W	TB : 3Ø 220V 4P	Terninal Box
NEOM	60				TC : 3Ø 380V 4P	T1: 大端子盒
NECGM					TJ : 3Ø 220V/380V 4P	Big Terninal box
NEOCGM					TK : 3Ø 480V 4P	B: 電磁剎車
NEOVM					TM : 3Ø 220V/460V 4P	Electromagnetic
NEOHCGM						Brake
NEHM						F: 風扇
NEGCM						Fan
NEOGCM						CF: 強制風扇
						Compulsory Fan
						V: 調速型
						Speed Variable
						W: 溫控開關
						Tem perature
						Control Switch

鋁合金蝸輪搭配微型系列選用表

Selection Table of Aluminum Alloy Worm Gear Reducer in Combination with Compact Gearmotor

	鋁合金蝸輪減速機 Aluminum Alloy Worm Reducer		減速比 Reducer Ratio	搭配微型減速機 Matching Compact Reducer
	機型 Type	型號 Model		
搭配微型圓軸馬達 In Combination with Compact Round-Shaft Motor	NECM NEOCM	30#、40#	5~60	CM09IA <input type="checkbox"/> -LK
	NEHCM NEOHCM	40#、60#	100~1600	CM09IA <input type="checkbox"/> -LK
搭配微型減速機馬達 In Combination with Compact Gearmotor		NECGM NEOCGM	50#	100~1600
	30#		15~18000 15~14400	CG08 <input type="checkbox"/> S11/CM08 <input type="checkbox"/> CG09 <input type="checkbox"/> S11/CM09 <input type="checkbox"/>
	NEHCGM NEOHCGM	40#	15~18000 15~14400	CG09 <input type="checkbox"/> S11/CM09 <input type="checkbox"/>
		30#、40#	300~480000	CG08 <input type="checkbox"/> S11/CM08 <input type="checkbox"/> CG09 <input type="checkbox"/> S11/CM09 <input type="checkbox"/>
搭配微型齒軸馬達 In Combination with Compact Gear-Shaft Motor	NEGCM NEOGCM	30#、40#	12.5~150	CM09IG <input type="checkbox"/>

微型馬達長度及重量表 Compact Motor of Length & Weight

微型馬達 Compact Motor Model	功率 Power	標準 Standard		附剎車 Brake		調整型 Speed Variable		調速 + 強制風扇 Speed Variable & Fan		剎車調速 Speed Variable & Brake	
		長度 (m) Length	重量 (kg) Weight	長度 (m) Length	重量 (kg) Weight	長度 (m) Length	重量 (kg) Weight	長度 (m) Length	重量 (kg) Weight	長度 (m) Length	重量 (kg) Weight
CM09	40W	105	2.3	153	3.0	115.5	2.4	150	2.8	163.5	3.1
	60W	126	2.5	173	3.1	138	2.6	150	2.8	185	3.2
	90W	141	3.1	188	3.8	153	3.2	165	3.5	200	3.9

微型減速機馬達長度及重量表

Compact Gearmotor of Length & Weight

微型減速機 Compact Reducer Model	功率 Power	速比 Ratio	標準 Standard		附剎車 Brake		調整型 Speed Variable		調速 + 強制風扇 Speed Variable & Fan		剎車調速 Speed Variable & Brake	
			長度 (m) Length	重量 (kg) Weight	長度 (m) Length	重量 (kg) Weight	長度 (m) Length	重量 (kg) Weight	長度 (m) Length	重量 (kg) Weight	長度 (m) Length	重量 (kg) Weight
CG08	25W	3~75	129	2.1	174	2.6	139.5	2.2	-	-	184.5	2.7
		90~300	136	2.3	181	2.8	146.5	2.4	-	-	191.5	2.9
CG09	40W	3~75	161.6	3.5	209.6	4.2	172.1	3.6	206.6	4.0	220.1	4.3
		90~240	170.6	3.7	218.6	4.4	181.1	3.8	215.6	4.2	229.1	4.5
	60W	3~75	182.6	3.7	229.6	4.3	194.6	3.8	206.6	4.0	241.6	4.4
		90~240	191.6	3.9	238.6	4.5	203.6	4.0	215.6	4.2	250.6	4.6
	90W	3~75	197.6	4.3	244.6	5.0	209.6	4.4	221.6	4.7	256.6	5.1
		90~240	206.6	4.5	253.6	5.2	218.6	4.6	230.6	4.9	265.6	5.3

MODEL : NECM

搭配圓軸馬達

In Combination with Compact Round-Shaft Motor

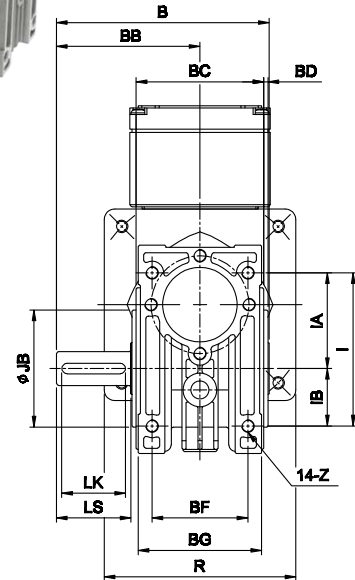
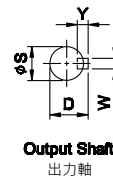
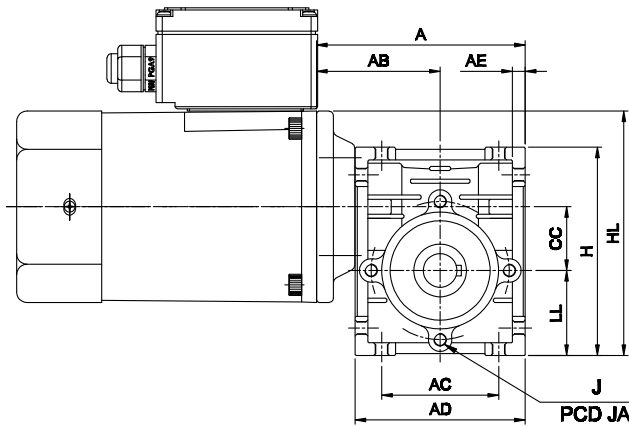

unit: mm

Model	CM	A	AB	AC	AD	AE	B	BB	BC	BD	BF	BG	CC	LL	H	HL	I	IA	IB	Z	出力軸 Output Shaft				Weight (kg)			
																					LS	S	D	WxYxLK		JA	JB	J
30	09	98	58	55	80	6	99.5	67.5	60	2	45	58	30	40	98	115	72	45	27	M6	35	16	18	5x5x30	65	55	8-M6	1.41
40	09	123	72	70	102	7.5	127	85	80	2	60	72	40	50	122	135	90	55	35	M8	40	20	22.5	6x6x35	77	60	12-M6	2.9

註：重量不含馬達 NOTE: Weight not include motor.

MODEL : NEOCM

搭配圓軸馬達

In Combination with Compact Round-Shaft Motor

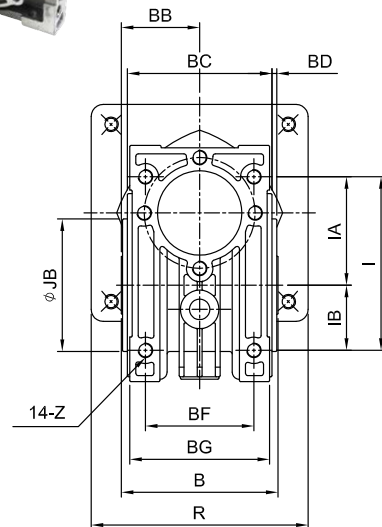
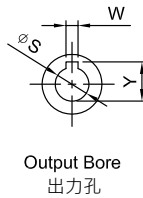
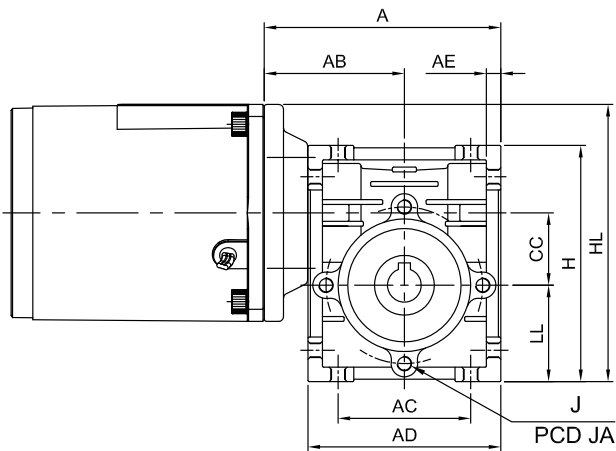

unit: mm

Model	CM	A	AB	AC	AD	AE	B	BB	BC	BD	BF	BG	CC	LL	H	HL	I	IA	IB	Z	出力孔 Output Bore				Weight (kg)		
																					W	S	Y	JA		JB	J
30	09	98	58	55	80	6	65	32.5	60	2	45	58	30	40	98	115	72	45	27	M6	5	14	16.3	65	55	8-M6	1.31
40	09	123	72	70	102	7.5	90	45	80	2	60	72	40	50	122	167	90	55	35	M8	6	20	22.8	77	60	12-M6	2.6

註：重量不含馬達 NOTE: Weight not include motor.

MODEL : NEHCM

搭配圓軸馬達

In Combination with Compact Round-Shaft Motor

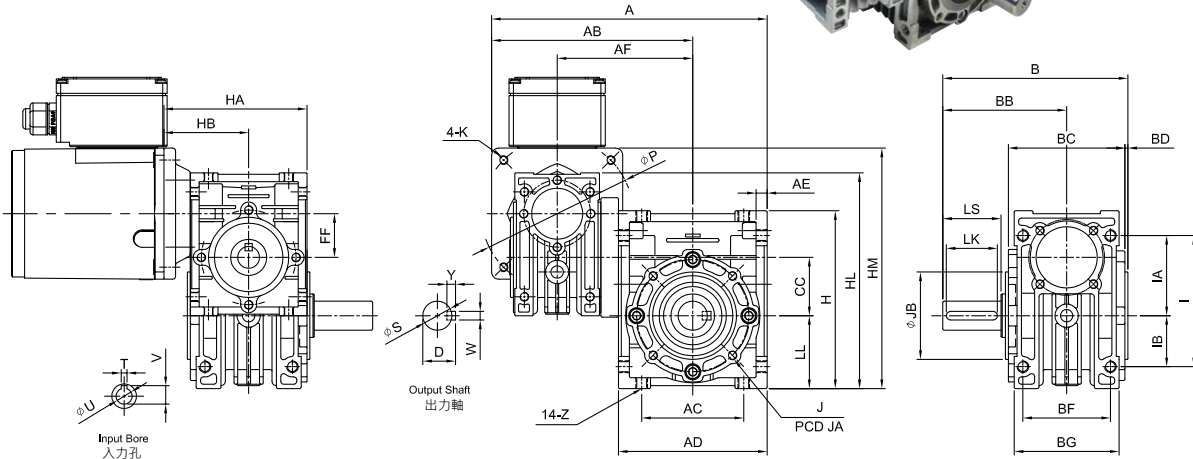
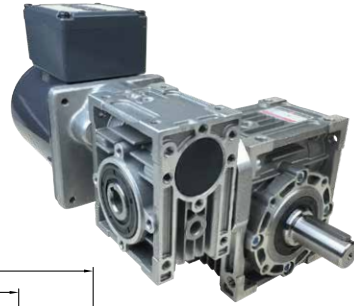

unit: mm

Model	CM	CC	FF	A	AB	AC	AD	AE	B	BB	BC	BD	BF	BG	H	HA	HB	HL	I	IA	IB	LL	Z	出力軸 Output Shaft						Weight (kg)			
																								LS	S	D	WxYxLK	JA	JB		J		
40	09	40	30	184	133	70	102	7.5	93	85	80	2	60	72	122	99	59	109	69	148	90	55	35	50	M8	40	20	22.5	6x6x35	77	60	12-M6	3.96
50	09	50	30	189	138	80	120	8.5	102	100	94	3	70	85	145	99	59	109	69	168	105	65	40	60	M10	50	25	28	8x7x45	95	70	12-M6	5.51
60	09	60	40	189	138	100	146	10	125	105	102	3	85	103	180	131	80	207	136	83	53	75	M10	50	25	28	8x7x45	120	80	12-M8	8.7		

註：重量不含馬達 NOTE: Weight not include motor.

MODEL : NEOHCM

搭配圓軸馬達

In Combination with Compact Round-Shaft Motor

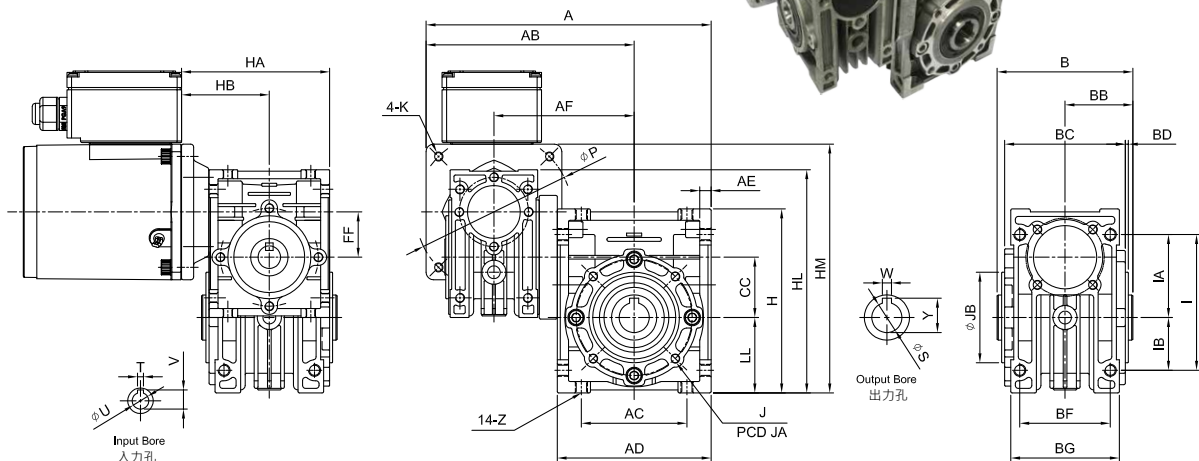

unit: mm

Model	CM	CC	FF	A	AB	AC	AD	AE	B	BB	BC	BD	BF	BG	H	HA	HB	HL	I	IA	IB	LL	Z	出力孔 Output Bore						Weight (kg)		
																								W	S	Y	JA	JB	J			
40	09	40	30	184	133	70	102	7.5	90	45	80	2	60	72	122	99	59	109	69	148	90	55	35	50	M8	6	20	22.8	77	60	12-M6	3.96
50	09	50	30	189	138	80	120	8.5	100	50	94	3	70	85	145	99	59	109	69	168	105	65	40	60	M10	8	25	28.3	95	70	12-M6	5.51
				202	142																											
60	09	60	40	243	170	100	146	10	110	55	102	3	85	103	180	131	80	207	136	83	53	75	M10	8	25	28.3	120	80	12-M8	8.7		

註：重量不含馬達 NOTE: Weight not include motor.

MODEL : NECGM

搭配微型減速機馬達

In Combination with Compact Gearmotor

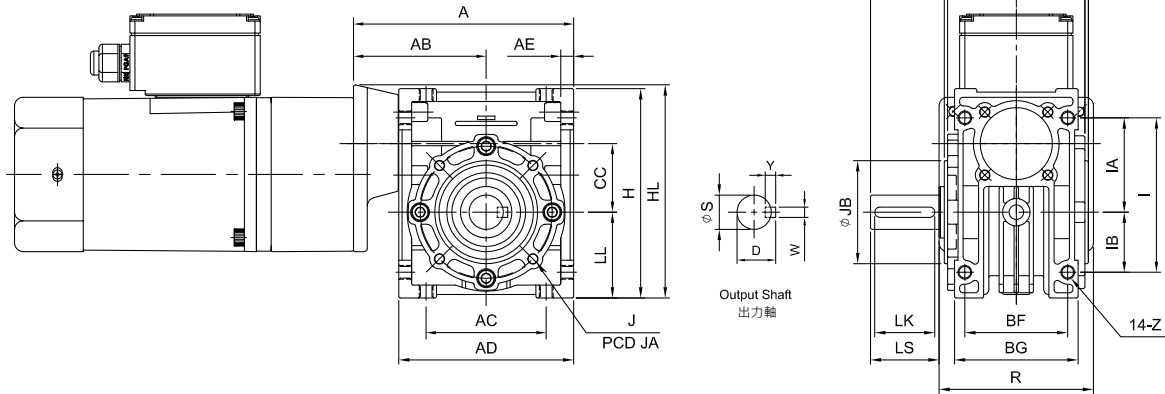
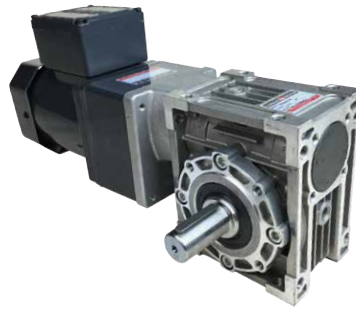

unit: mm

Model	CG	A	AB	AC	AD	AE	B	BB	BC	BD	BF	BG	CC	LL	H	I	IA	IB	Z	出力軸 Output Shaft					Weight (kg)		
																				LS	S	D	WxYxLK	JA		JB	J
30	08 09	99 107	59 67	55	80	6	99.5	67.5	60	2	45	58	30	40	98	72	45	27	M6	35	16	18	5x5x30	65	55	8-M6	1.41
40	09	131	80	70	102	7.5	127	85	80	2	60	72	40	50	122	90	55	35	M8	40	20	22.5	6x6x35	77	60	12-M6	2.9

註：重量不含馬達 NOTE: Weight not include motor.

MODEL : NEOCGM

搭配微型減速機馬達

In Combination with Compact Gearmotor

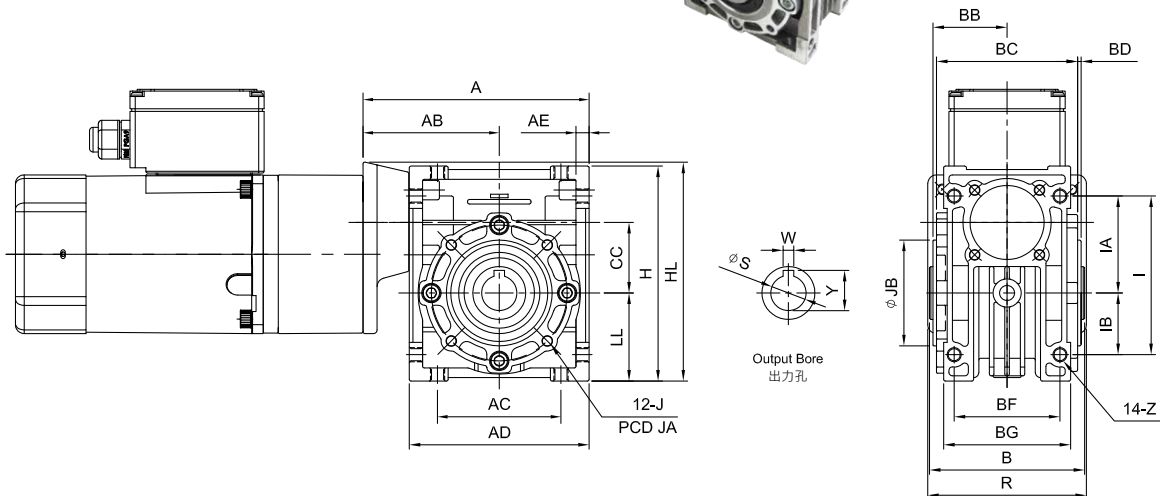

unit: mm

Model	CG	A	AB	AC	AD	AE	B	BB	BC	BD	BF	BG	CC	LL	H	I	IA	IB	Z	出力孔 Output Bore					Weight (kg)	
																				W	S	Y	JA	JB		J
30	08 09	99 107	59 67	55	80	6	65	32.5	60	2	45	58	30	40	98	72	45	27	M6	5	14	16.3	65	55	8-M6	1.31
40	09	131	80	70	102	7.5	90	45	80	2	60	72	40	50	122	90	55	35	M8	6	20	22.8	77	60	12-M6	2.6

註：重量不含馬達 NOTE: Weight not include motor.

MODEL : NEHCGM

搭配微型減速機馬達

In Combination with Compact Gearmotor

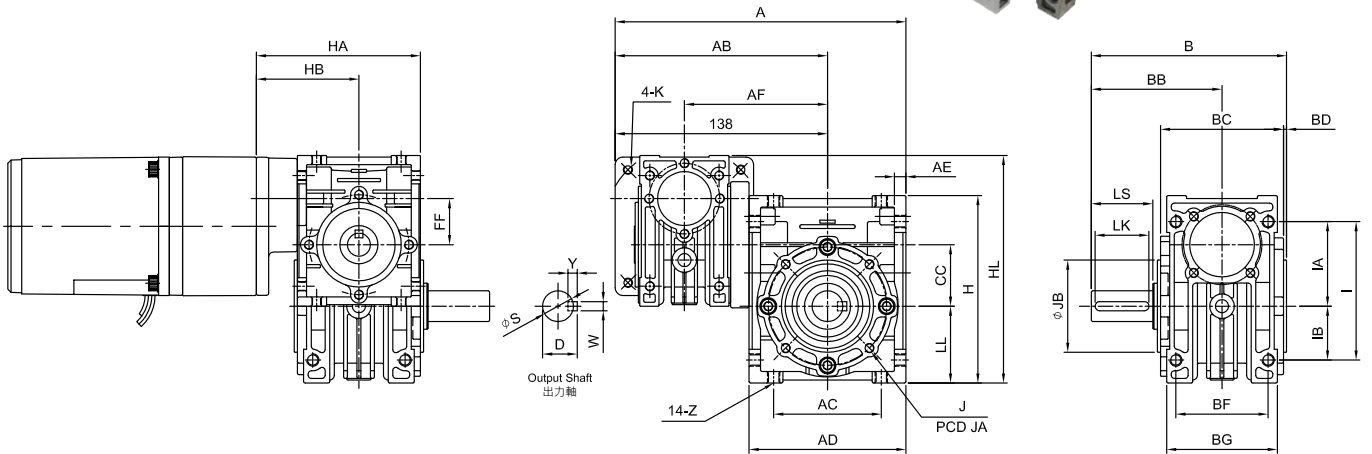

unit: mm

Model	CG	CC	FF	A	AB	AC	AD	AE	AF	B	BB	BC	BD	BF	BG	H	HA	HB	HL	I	IA	IB	LL	Z	出力軸 Output Shaft					Weight (kg)		
																									LS	S	D	WxYxLK	JA		JB	J
40	09	40	30	189	138	70	102	7.5	93	127	85	80	2	60	72	122	105	65	148	90	55	35	50	M8	40	20	22.5	6x6x35	77	60	12-M6	
50	09	50	30	207	147	80	120	8.5	102	150	100	94	3	70	85	145	105	65	168	105	65	40	60	M10	50	25	28	8x7x45	95	70	12-M6	

註：重量不含馬達 NOTE: Weight not include motor.

MODEL : NEOHCGM

搭配微型減速機馬達

In Combination with Compact Gearmotor

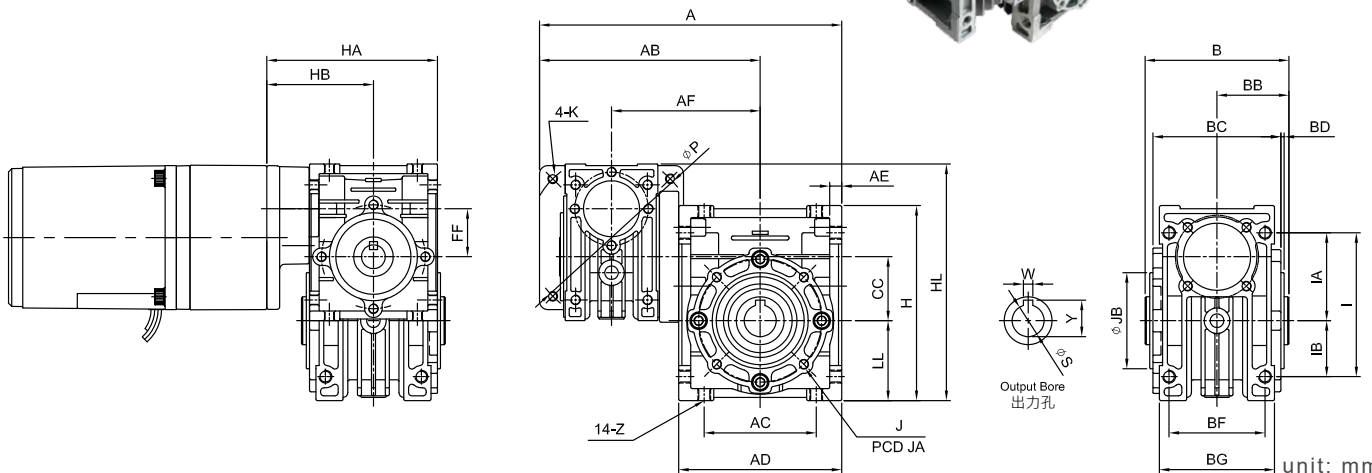
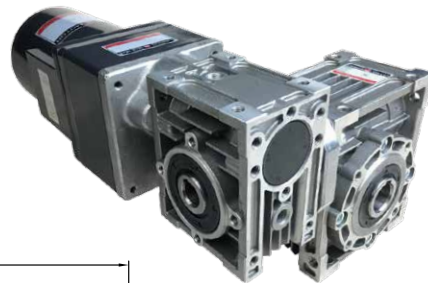

unit: mm

Model	CG	CC	FF	A	AB	AC	AD	AE	AF	B	BB	BC	BD	BF	BG	H	HA	HB	HL	I	IA	IB	LL	Z	出力孔 Output Bore					Weight (kg)	
																									W	S	Y	JA	JB		J
40	09	40	30	189	138	70	102	7.5	93	90	45	80	2	60	72	122	105	65	148	90	55	35	50	M8	6	20	22.8	77	60	12-M6	
50	09	50	30	207	147	80	120	8.5	102	100	50	94	3	70	85	145	105	65	168	105	65	40	60	M10	8	25	28.3	95	70	12-M6	

註：重量不含馬達 NOTE: Weight not include motor.

MODEL : NEGCM

搭配微型齒軸馬達

In Combination with Compact Gear-Shaft Motor

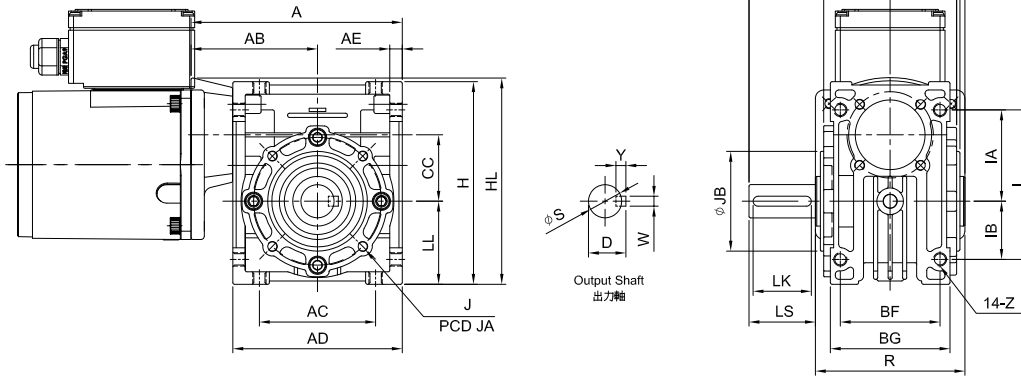
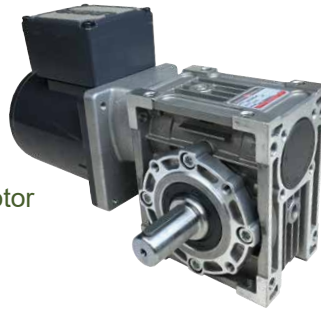

unit: mm

Model	CM	A	AB	AC	AD	AE	B	BB	BC	BD	BF	BG	CC	LL	H	I	IA	IB	Z	出力孔 Output Bore						Weight (kg)
																				W	S	Y	JA	JB	J	
30	09	107	67	55	80	6	97.5	67.5	60	2	45	58	30	40	98	72	45	27	M6	5	16	18	65	55	8-M6	1.31
40	09	133	82	70	102	7.5	127	85	80	2	60	72	40	50	122	90	55	35	M8	6	20	22.8	77	60	12-M6	2.6

註：重量不含馬達 NOTE: Weight not include motor.

MODEL : NEOGCM

搭配微型齒軸馬達

In Combination with Compact Gear-Shaft Motor

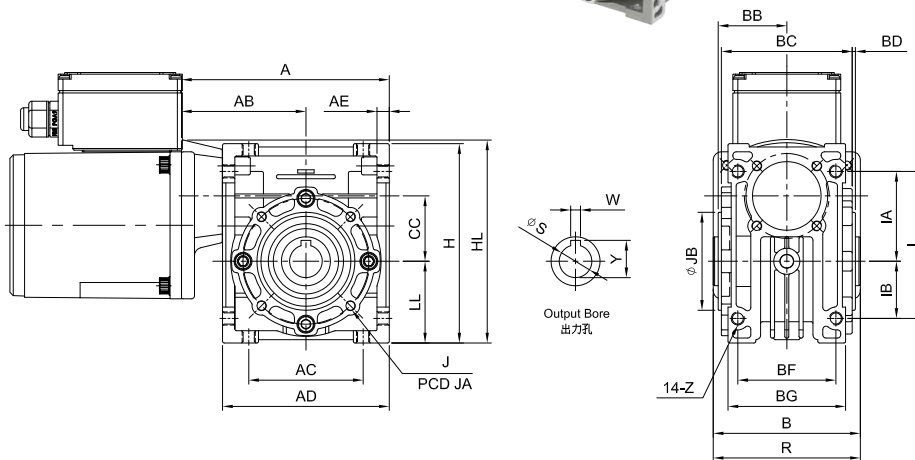

unit: mm

Model	CM	A	AB	AC	AD	AE	B	BB	BC	BD	BF	BG	CC	LL	H	HL	I	IA	IB	Z	出力孔 Output Bore						Weight (kg)
																					S	D	WxYxLK	JA	JB	J	
30	09	107	67	55	80	6	65	32.5	60	2	45	58	30	40	98	72	72	45	27	M6	14	16.3	5x5x30	65	55	8-M6	1.41
40	09	133	82	70	102	7.5	90	45	80	2	60	72	40	50	122	90	90	55	35	M8	20	22.5	6x6x35	77	60	12-M6	2.9

註：重量不含馬達 NOTE: Weight not include motor.

MEMO

伺服用減速機 Reducers for Servo Motor

高精度行星減速機 High Precision Planetary Reducers



直交軸伺服用減速機
High Precision Right Angle Reducers



伺服用中空旋轉平台減速機
Hollow Rotary Actuator Reducers



一般傳動減速機 General Speed Reducers

齒輪減速機 Gear Reducers



蝸輪減速機 Worm Gear Reducers

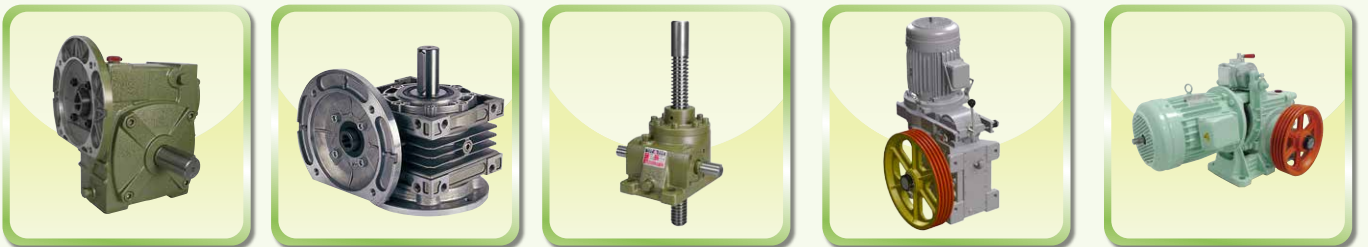

一般傳動減速機 Reducers



傳動軸用減速機 Gearbox for Power Transmission

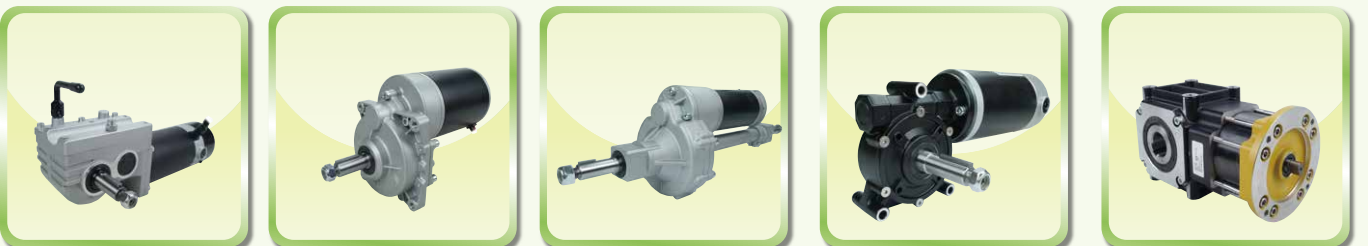

機械手臂減速機 Robot Reducers

諧波減速機 ROBONICDRIVE



高精度擺線減速機 CYKODRIVE

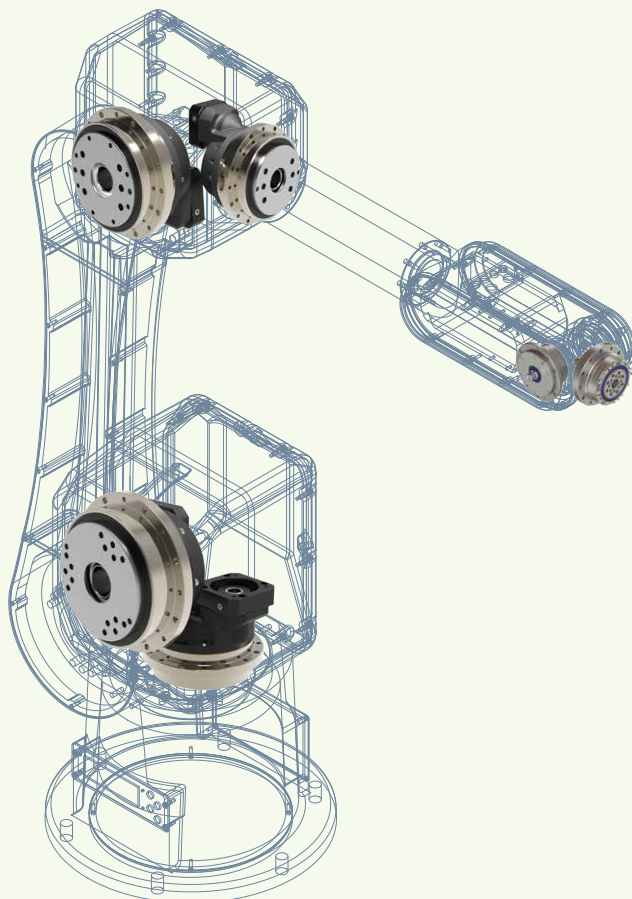

小型齒輪減速機 Small Gear Reducers



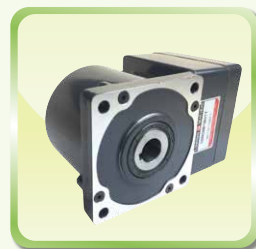

2023 年 11 月版

- 由於產品改良，未經通告變更印刷製品規格，請諒察。
- 由於印刷特性與拍攝技術的關係，印刷顏色與實物稍有差異，請諒察。
- 產品專利及版權所有，非經本公司同意，不得轉載本刊任何圖文或仿冒商品。
- 本目錄於製作時已力求完美，但因機種繁多，校稿疏失在所難免，請於訂貨時與業務人員進行確認。

November, 2023

- We ask for your understanding if due to product improvements and the product in this catalogue have not yet been updated.
- We also ask for your understanding if due to printing limitations the objects and colors in this catalogue do not match the actual products exactly.
- The products in this catalogue have been registered with the patents office.
- The reprinting of this publication in any form or the imitation of any of the products described within is expressly forbidden without the express permission of the LI MING MACHINERY CO., LTD.

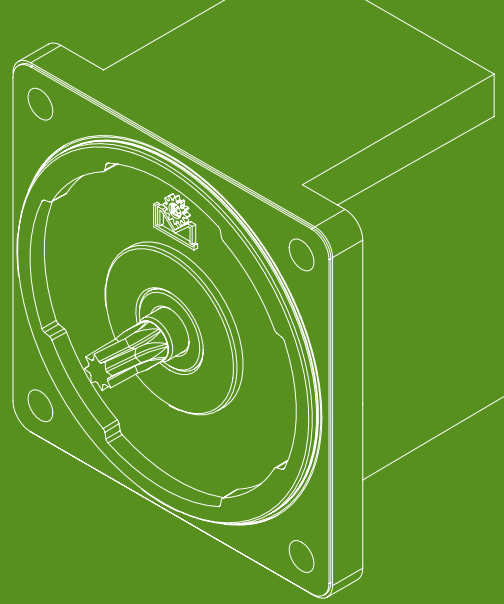
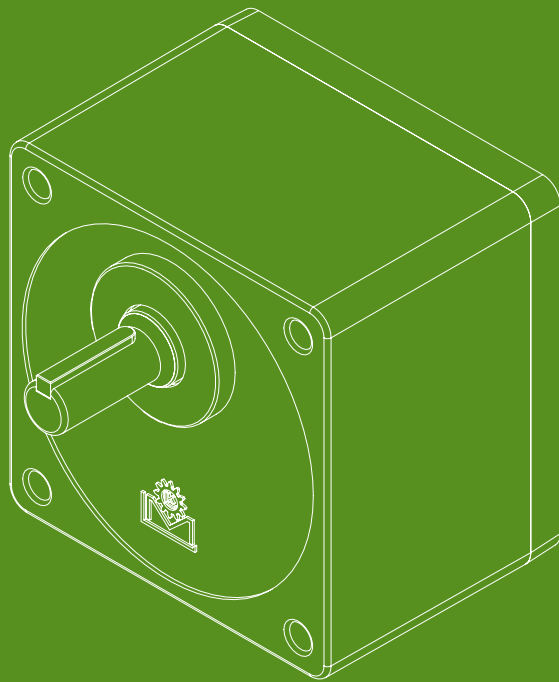

利茗機械股份有限公司
LI MING MACHINERY CO., LTD.

臺中市潭子區潭富路一段168號

No. 168, Sec. 1, Tanfu Rd.,

Tanzi Dist., Taichung City 427226, Taiwan

Tel: 886-4-25314888 Fax: 886-4-25338982

Http: //www.li-ming.com E-mail: info@li-ming.com