

# GEAR-WORM REDUCER SERIES

## 齒蝸輪減速機系列

# AS



## Indication of Model Numbers







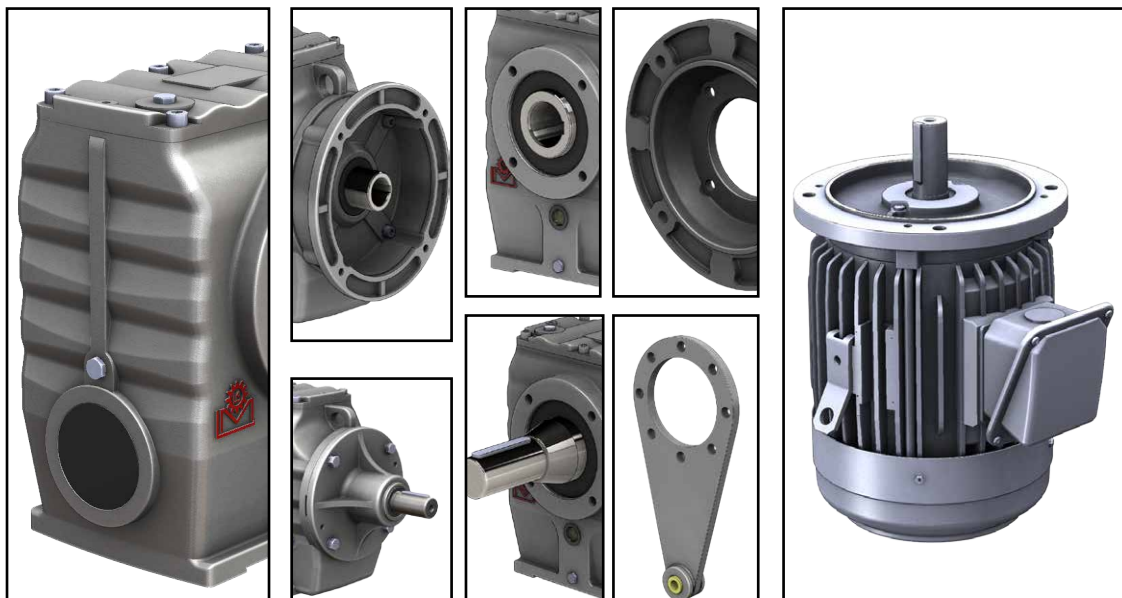





### 機種型號表示

#### 產品樣式選擇

AS	067	B	O	F	60	007	A	R
減速機型 Type	型號 Model	入力表示 Input	出力軸 Output	出力法蘭 Output Flange	減速比 Ratio	入力 kW Input kW	安裝方向 Installation Direction	軸向 Shaft Direction
AS	047 057 067 077 087 097	B 入力法蘭 Input Flange	O 中空軸 Hollow Shaft	F 法蘭型 Flange  A 側固型 Torque Arm  <input type="checkbox"/> 無 Nothing	20,30,40 45,60,80 90,100 120,160 180,200 240	0.2kW : 002 0.4kW : 004 0.75kW : 007 1.5kW : 015 2.2kW : 022 3.75kW : 037 5.5kW : 055 7.5kW : 075 11kW : 110 15kW : 150	A B C	R 右軸 Right Shaft  L 左軸 Left Shaft



## ■ 產品樣式選擇 Selection of Type

	標準型 Standard	F 出力法蘭型 Output Flange	A 側固型 Torque arm
B 入力法蘭 Input Flange + O 中空出力軸 Hollow shaft	 BO	 BOF	 BOA
B 入力法蘭 Input Flange + S 實心出力軸 Solid shaft	 BS	 BSF	 BSA
D 實心入力軸 Input shaft + O 中空出力軸 Hollow shaft	 DO	 DOF	 DOA
D 實心入力軸 Input shaft + S 實心出力軸 Solid shaft	 DS	 DSF	 DSA

## ■ 重量表及油量表 Weight & Oil Capacities

Model	AS047		AS057		AS067		AS077		AS087		AS097	
	重量 (kg) Weight	油量 (ℓ) Oil	重量 (kg) Weight	油量 (ℓ) Oil	重量 (kg) Weight	油量 (ℓ) Oil	重量 (kg) Weight	油量 (ℓ) Oil	重量 (kg) Weight	油量 (ℓ) Oil	重量 (kg) Weight	油量 (ℓ) Oil
BO DO	15	0.8	19	1	27	1.5	45	2	75	3	140	5
BOF · BOA DOF · DOA	16	0.8	20	1	29	1.5	47	2	78	3	145	5
BS DS	16	0.8	20	1	29	1.5	47	2	78	3	145	5
BSF · BSA DSF · DSA	18	0.8	22	1	33	1.5	50	2	80	3	150	5

重量不含馬達及潤滑油。 The weight does not include motor and lubricant.

# GEAR-WORM REDUCER SERIES

## 齒蝸輪減速機系列

### 分解系統圖 System Drawing

MODEL : AS

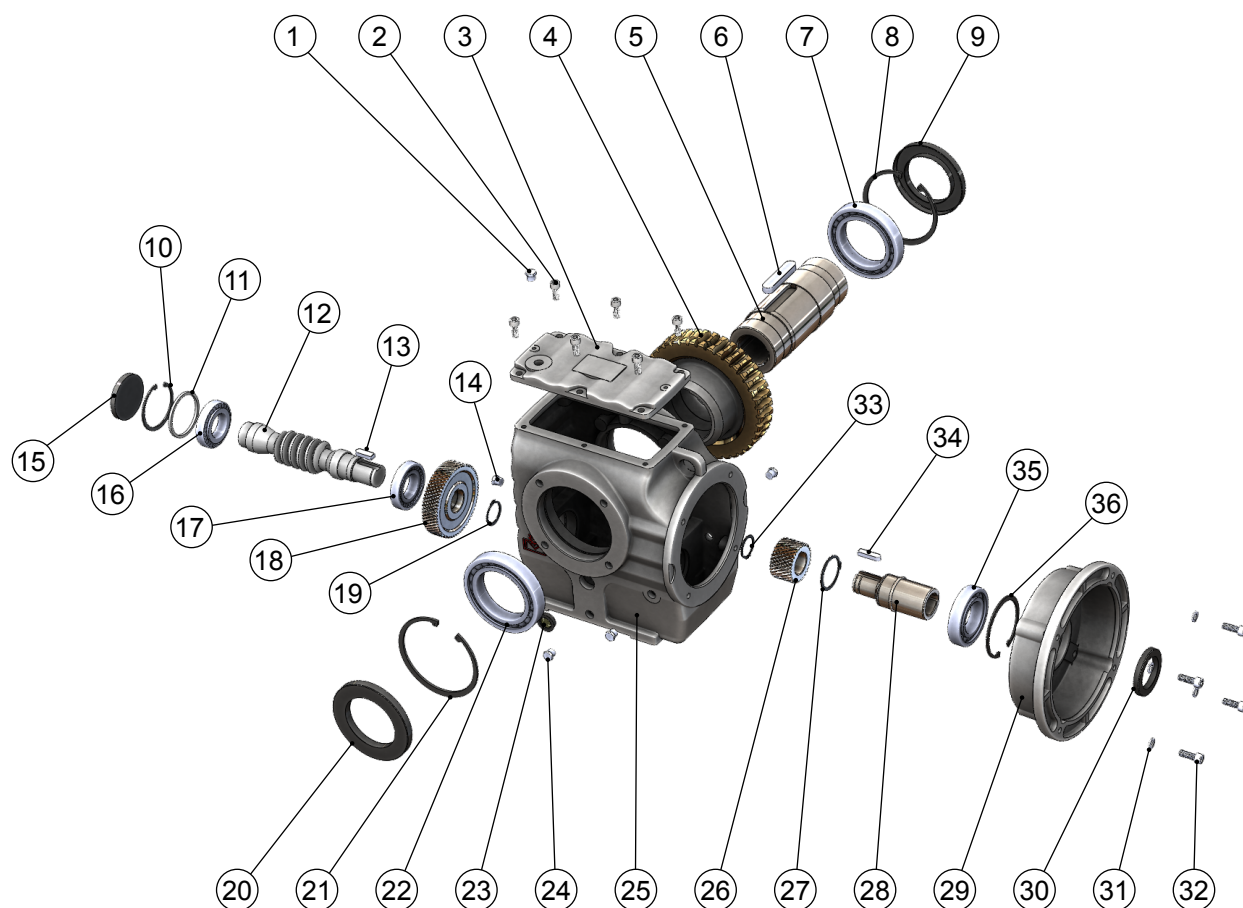

NO.	零件名稱	Name of Parts	NO.	零件名稱	Name of Parts	NO.	零件名稱	Name of Parts
1	油栓	Oil Plug	13	鍵	Key	25	齒輪箱	Outer Shell
2	內六角螺絲	Hex Socket Cap Screw	14	油栓	Oil Plug	26	A 齒輪	A Gear
3	上蓋	Cover	15	密式油封	Oil Seal	27	S 扣環	S Snap Ring
4	蝸輪	Worm Wheel	16	滾錐軸承	Taper Roller Bearing	28	入力軸	Input Shaft
5	出力軸	Output Shaft	17	滾錐軸承	Taper Roller Bearing	29	馬達盤	Motor Flange
6	鍵	Key	18	B 齒輪	B Gear	30	油封	Oil Seal
7	軸承	Ball Bearing	19	S 扣環	S Snap Ring	31	華司	Washer
8	R 扣環	R Snap Ring	20	油封	Oil Seal	32	內六角螺絲	Hex Socket Cap Screw
9	油封	Oil Seal	21	R 扣環	R Snap Ring	33	S 扣環	S Snap Ring
10	R 扣環	R Snap Ring	22	軸承	Bearing	34	鍵 K	Key
11	墊片	Packing	23	油鏡	Oil Gauge	35	軸承	Bearing
12	蝸桿	Worm Shaft	24	排油栓	Drain Plug	36	R 扣環	R Snap Ring

## ■ 安裝方向 Installation Direction

● 油面計  
Oil Indicator

▼ 注油栓  
Oil Plug

⚡ 排油栓  
Oil Drain Plug

◆ 正常的使用方向可以使減速機保持較高的壽命。  
The life time of gear reducer can be prolonged in proper direction.

◆ 安裝時請注意油面計、注油栓及排油栓的位置以便日後維護。  
Please note the positions of oil gauge, oil filling plug and oil drain plug to facilitate the maintenance afterwards.

◆ 減速機使用方向特殊時，請與我們連繫。  
For special installation direction, please contact us.

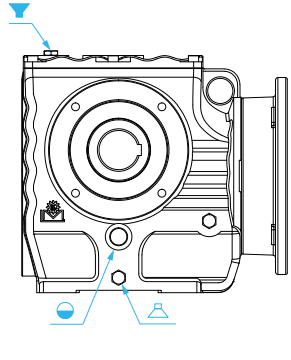
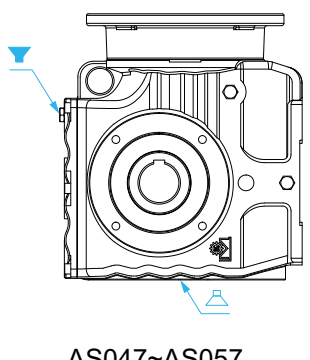
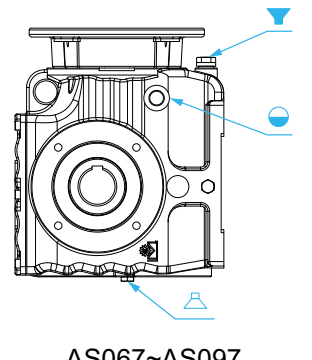
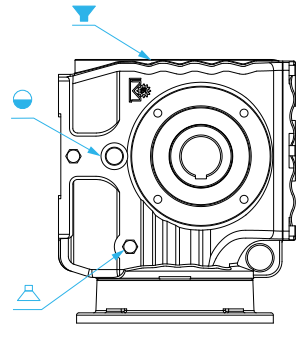
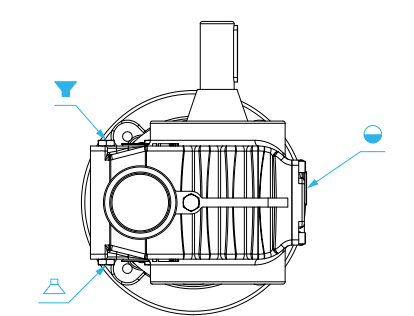
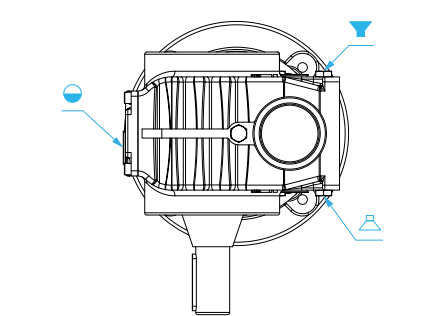
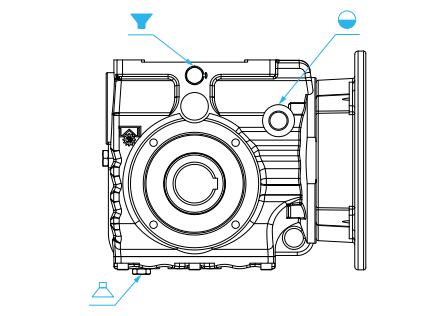
A 標準使用 Standard	B 入力在上使用 Input Above		C 入力在下使用 Input Below
	 <p style="text-align: center;">AS047~AS057</p>	 <p style="text-align: center;">AS067~AS097</p>	
D 出力向上使用 Output Shaft Above	E 出力向下使用 Output Shaft Below	F 倒吊安裝 Reverse Installation	
			

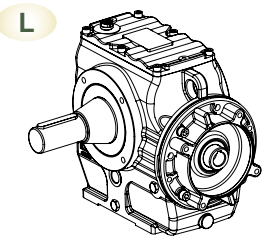
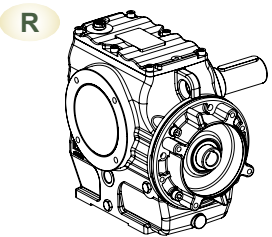
軸向選擇 Shaft Direction	
<p>L</p> 	<p>R</p> 

- ◆ R：右軸 (入力面對自己·出力軸在右方)  
Right Shaft (input to the face; output shaft to the right)
- ◆ L：左軸 (入力面對自己·出力軸在左方)  
Left Shaft (input to the face; output shaft to the left)

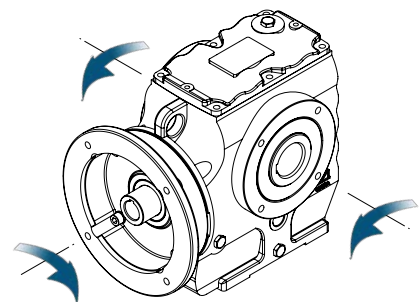

旋轉方向  
Rotation Directions

# GEAR-WORM REDUCER SERIES

## 齒蝸輪減速機系列

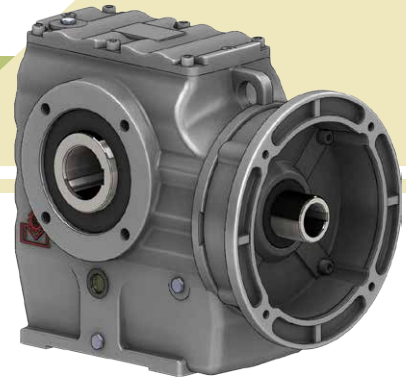

MODEL : AS047

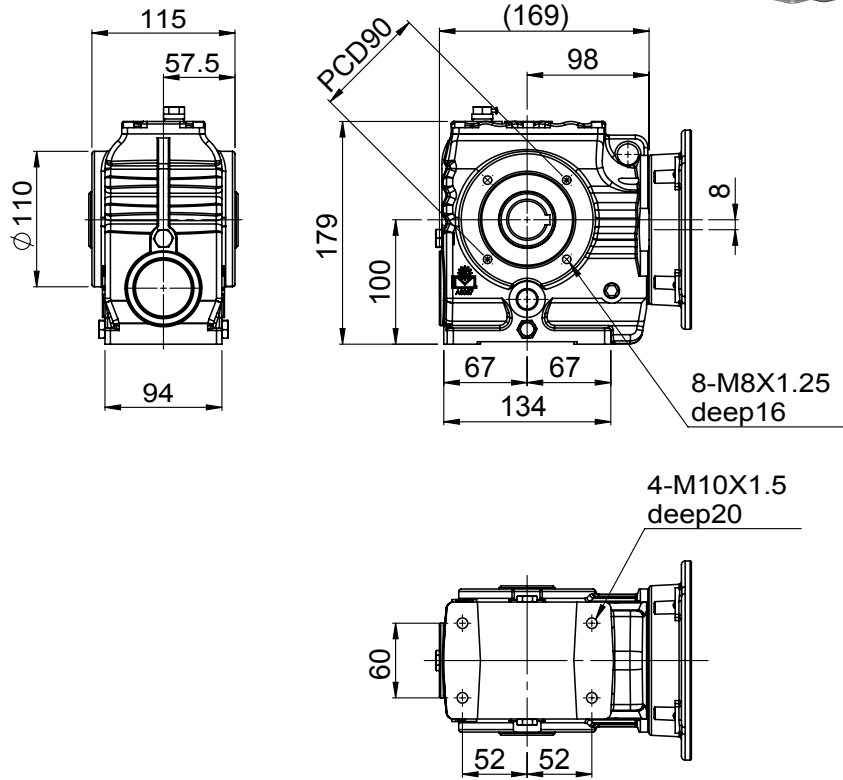

### 入力尺寸 Input

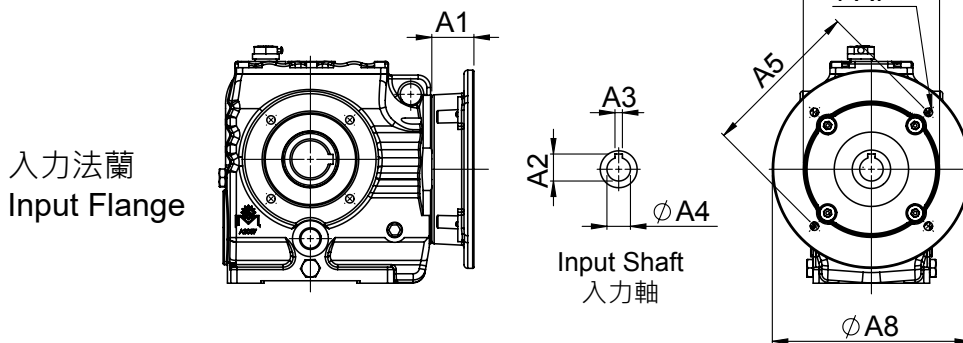

unit: mm

Power	A1	A2	A3	A4	A5	A6	A7	A8
0.2 kW	34	12.7	4	11	130	110	M8x1.25	160
0.4 kW	34	16.3	5	14	130	110	M8x1.25	160
0.75 kW	51	21.8	6	19	165	130	M10x1.5	200



### 出力尺寸 Output

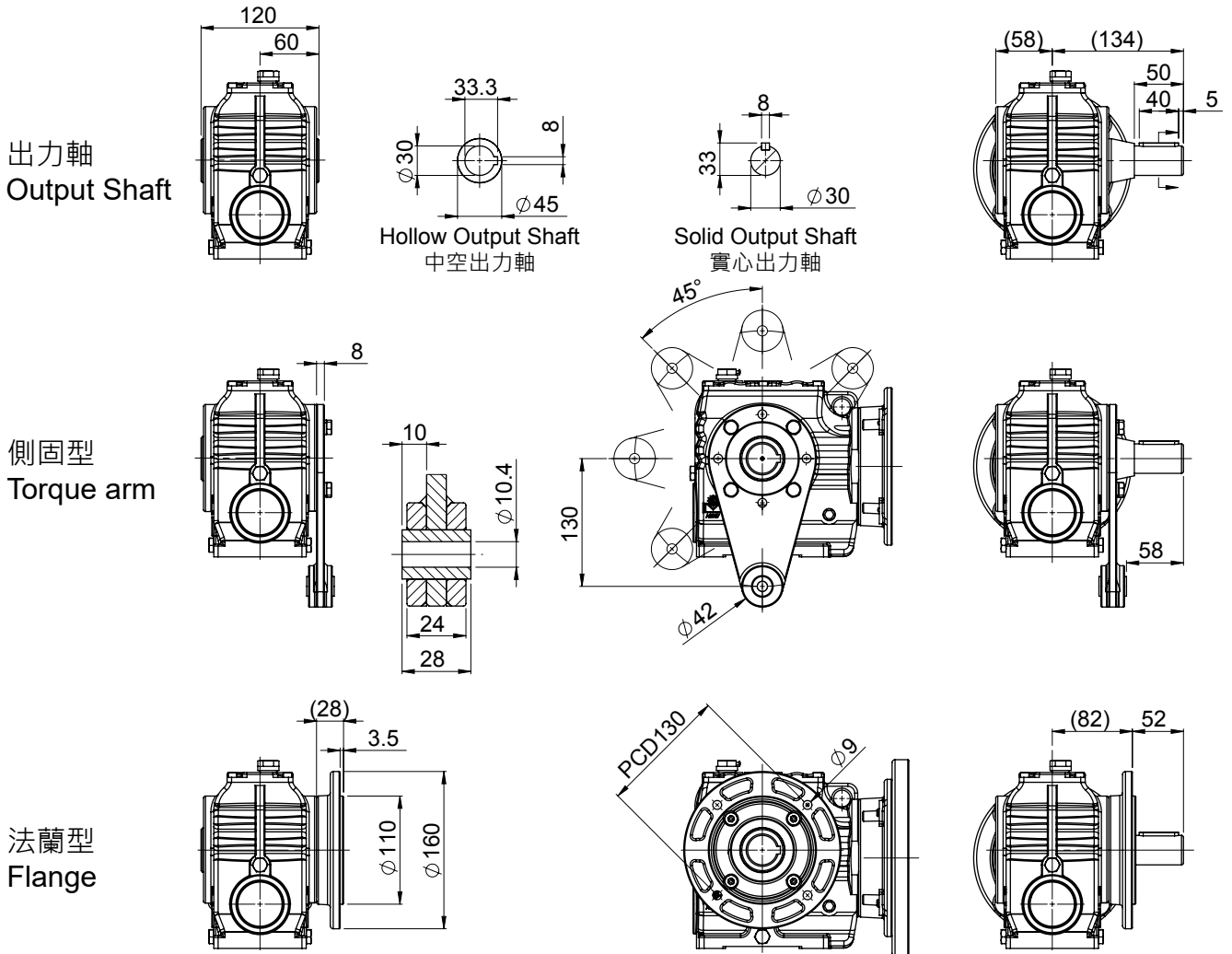

Power 實際減速比 Actual Ratio	0.2kW		0.4kW		0.75kW	
	OT(Nm)	SF	OT(Nm)	SF	OT(Nm)	SF
20	16	6.87	34	3.23	70	1.57
30	25	5.05	52	2.43	105	1.20
40	33	4.14	69	1.98	140	0.97
45	35	3.35	73	1.60	149	0.78
60	47	2.71	98	1.30	198	0.64
80	62	2.13	127	1.04	258	0.51
90	60	2.00	123	0.97	250	0.48
100	62	1.50	129	0.72		
120	80	1.62	164	0.79		
140 (143.5)	94	1.10	193	0.53		
160	103	1.20	213	0.58		
180	107	0.97				
200	125	0.88				
240	143	0.78				

# GEAR-WORM REDUCER SERIES

## 齒蝸輪減速機系列

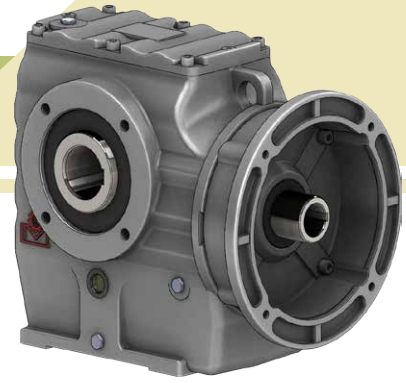

MODEL : AS057

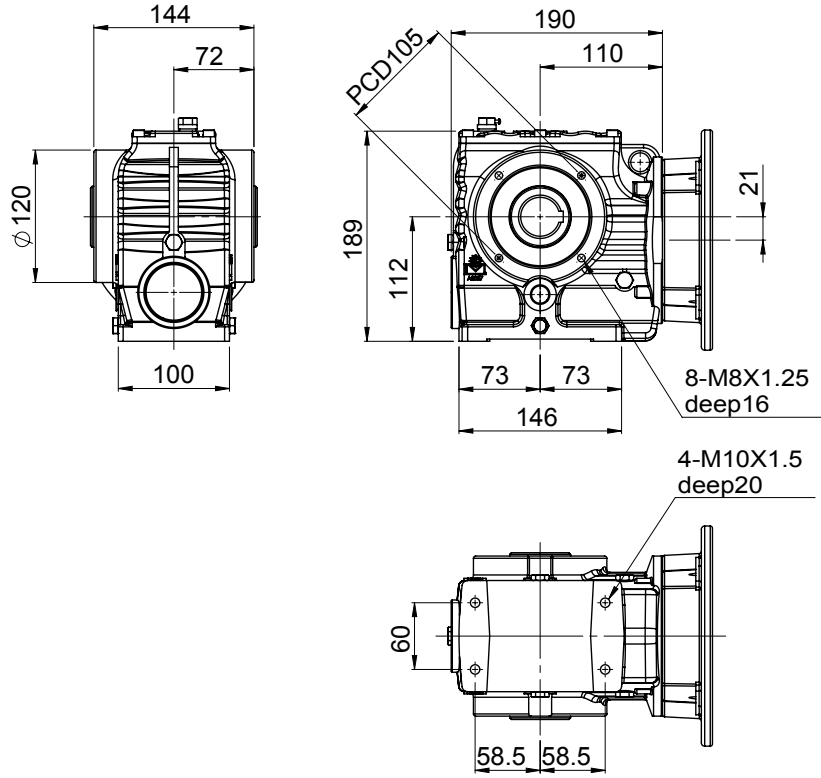

### 入力尺寸 Input

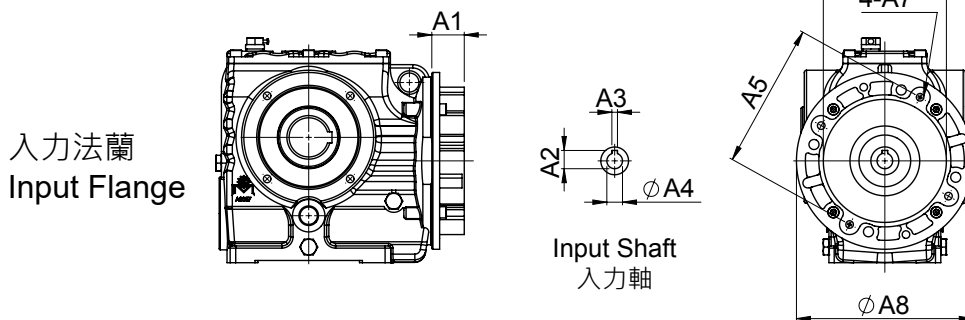

unit: mm

Power	A1	A2	A3	A4	A5	A6	A7	A8
0.4 kW	29	16.3	5	14	130	110	M8x1.25	160
0.75 kW	45	21.8	6	19	165	130	M10x1.5	200
1.5 kW	45	27.3	8	24	165	130	M10x1.5	200

### 出力尺寸 Output

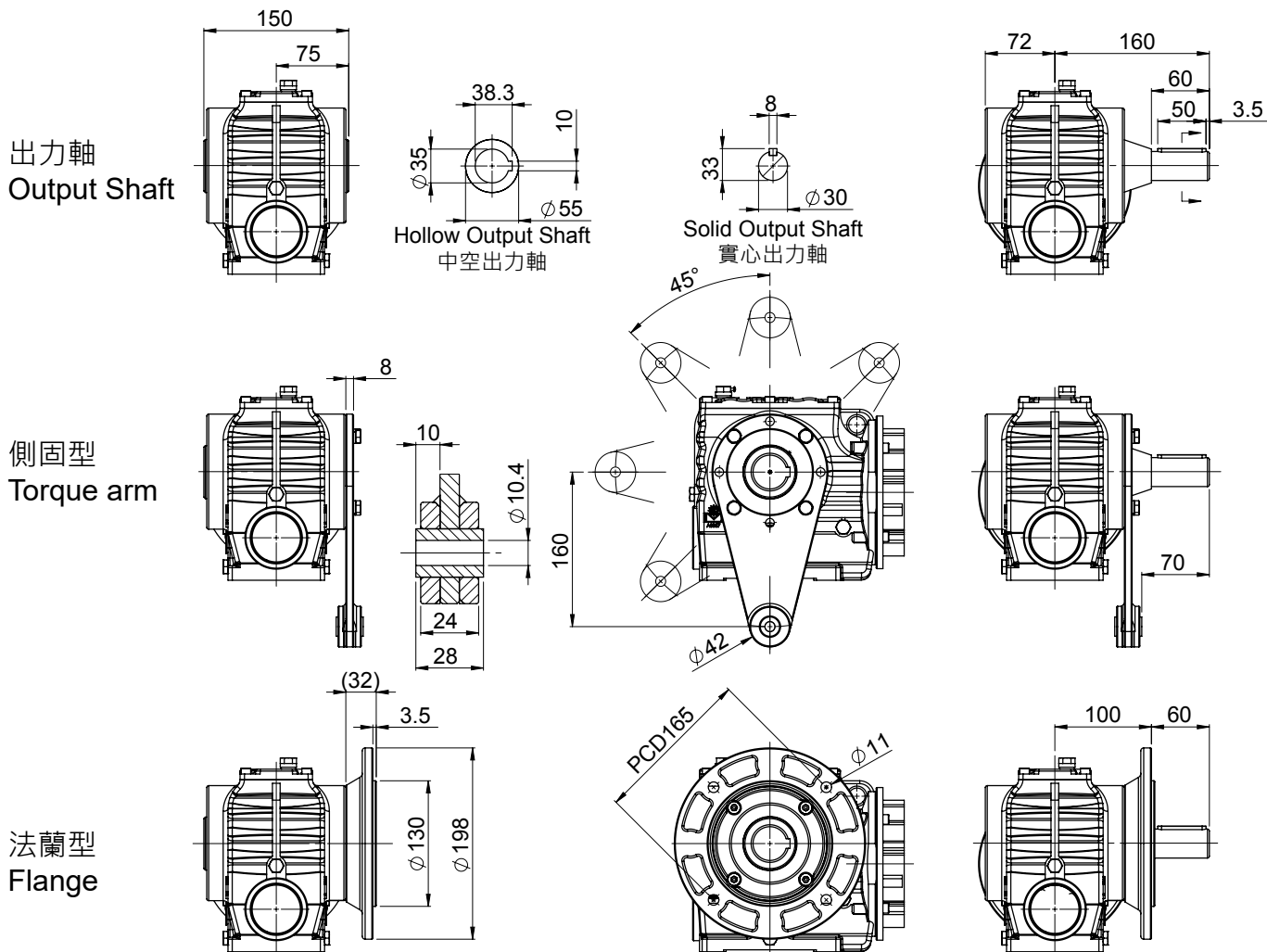

Power 實際減速比 Actual Ratio	0.4kW		0.75kW		1.5kW	
	OT(Nm)	SF	OT(Nm)	SF	OT(Nm)	SF
20	35	5.61	72	2.72	144	1.36
30	53	4.28	108	2.10	216	1.05
40	71	3.42	144	1.68	288	0.84
45	76	2.90	154	1.43	309	0.71
60	101	2.38	206	1.17	412	0.58
80	132	1.80	268	0.88		
90	132	1.71	268	0.84		
100	135	1.33	274	0.65		
120	176	1.39	358	0.68		
140 (143.5)	202	0.99	411	0.48		
160	226	1.04	458	0.51		
180	232	0.80				
200	270	0.79				
240	310	0.64				



# GEAR-WORM REDUCER SERIES

## 齒蝸輪減速機系列

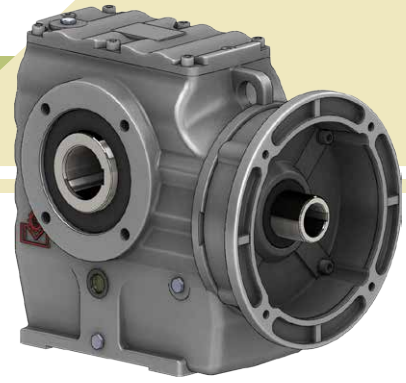

MODEL : AS067

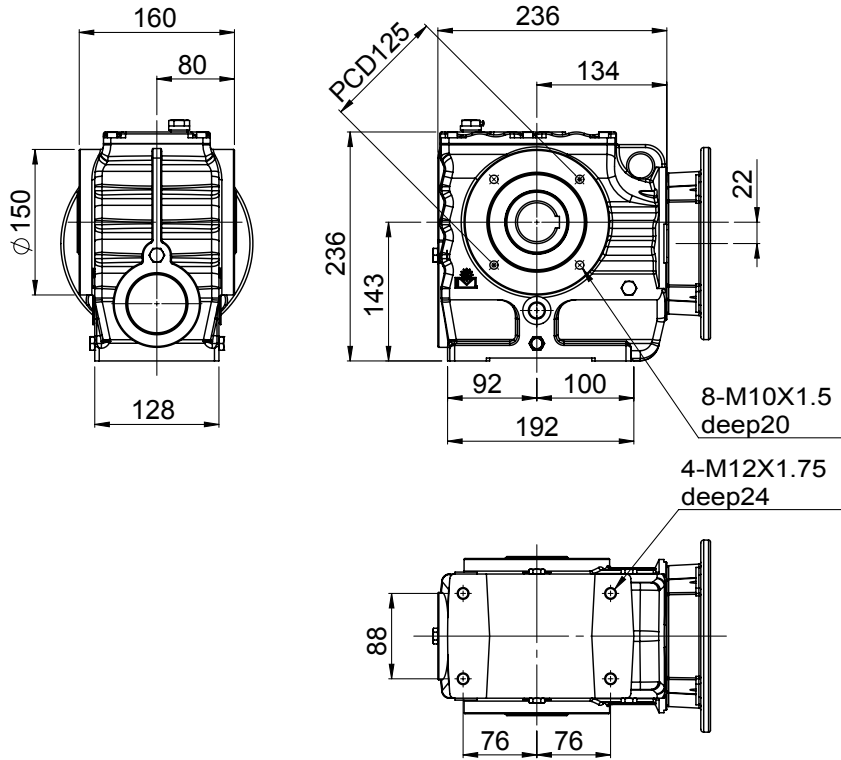

### 入力尺寸 Input

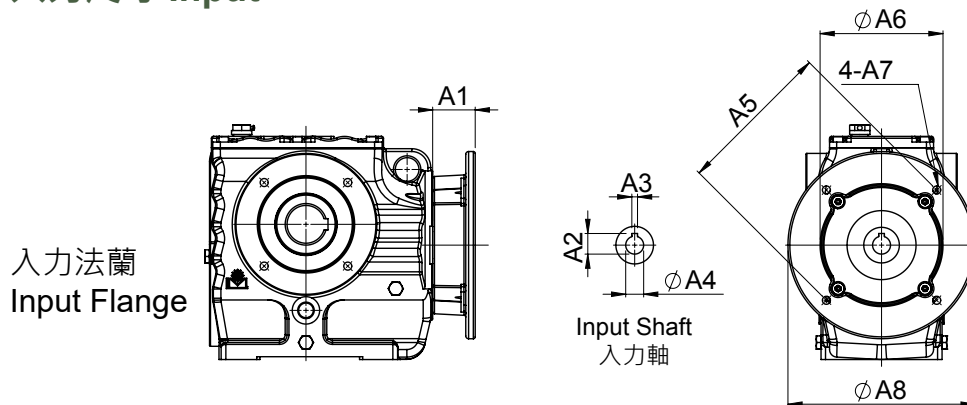

unit: mm

Power	A1	A2	A3	A4	A5	A6	A7	A8
0.75 kW	45	21.8	6	19	165	130	M10x1.5	200
1.5 kW	45	27.3	8	24	165	130	M10x1.5	200
2.2 kW 3.7 kW	59	31.3	8	28	215	180	M12x1.75	250

## 出力尺寸 Output

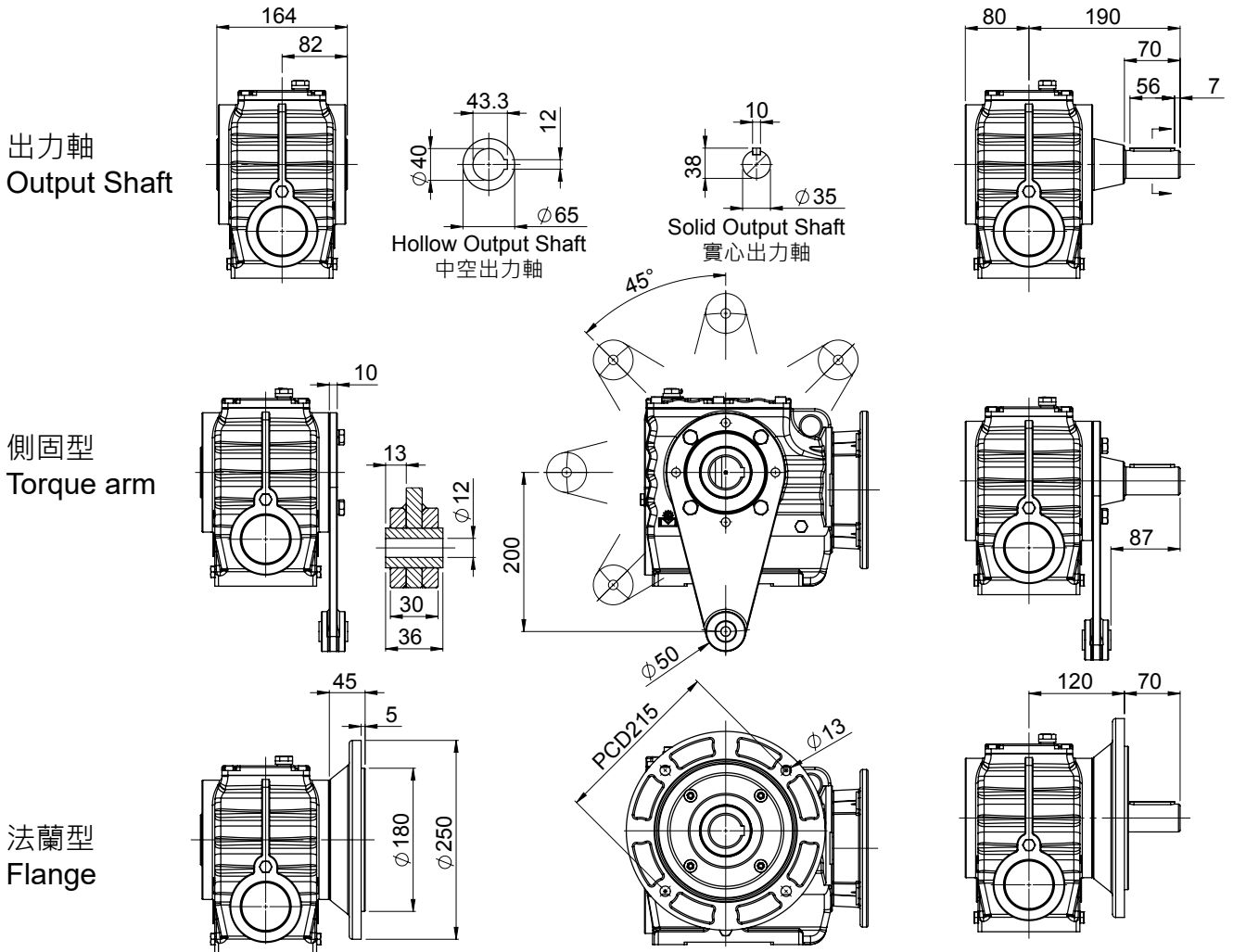

Power	0.75kW		1.5kW		2.2kW		3.7kW	
實際減速比 Actual Ratio	OT(Nm)	SF	OT(Nm)	SF	OT(Nm)	SF	OT(Nm)	SF
20	72	5.16	145	2.56	213	1.74	359	1.03
30	109	3.96	218	1.98	320	1.35	539	0.8
40	145	3.25	291	1.62	427	1.1	718	0.65
45	154	2.62	309	1.3	453	0.89	763	0.53
60	206	2.15	412	1.07	605	0.73		
80	258	1.46	517	0.72	758	0.49		
90	268	1.49	537	0.74	788	0.5		
100	224	1.42	449	0.71				
120	358	1.22	717	0.6				
140 (141)	336	1.07	673	0.53				
160	425	0.88						
180	434	0.66						
200	449	0.56						
240	579	0.53						

# GEAR-WORM REDUCER SERIES

## 齒蝸輪減速機系列

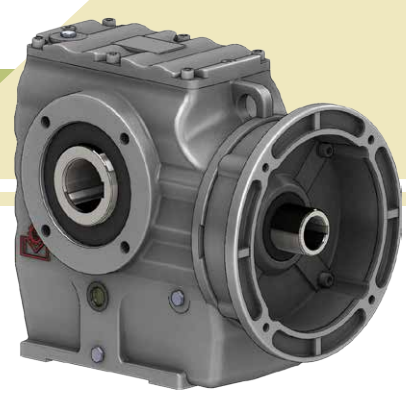

MODEL : AS077

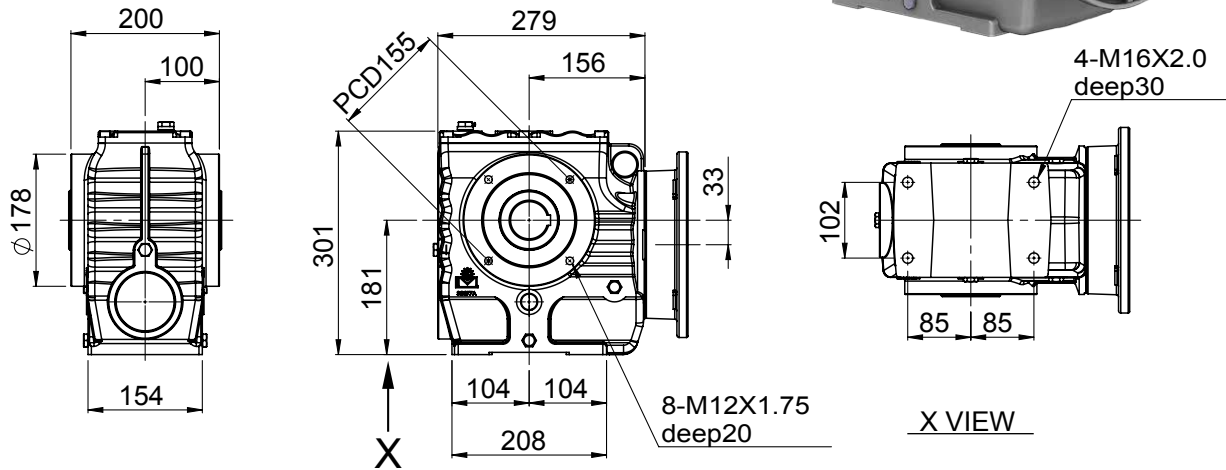

### 入力尺寸 Input

入力法蘭  
Input Flange

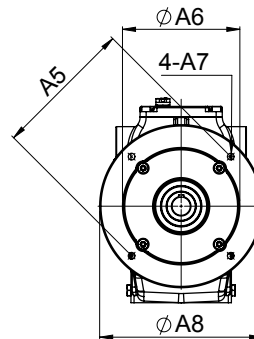
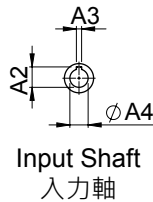
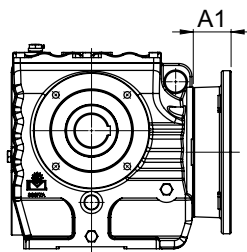

入力軸  
Input Shaft

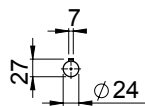
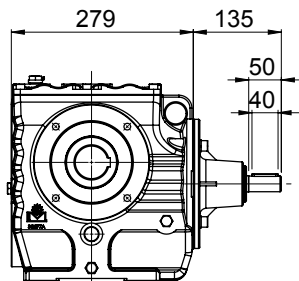

入力軸式僅生產 1.5kW、2.2kW、3.7kW。 The input shaft only produces 1.5kW, 2.2kW, 3.7kW.

unit: mm

Power	A1	A2	A3	A4	A5	A6	A7	A8
1.5 kW	45	27.3	8	24	165	130	M10x1.5	200
2.2 kW 3.7 kW	58	31.3	8	28	215	180	M12x1.75	250
5.5 kW	76	41.3	10	38	265	230	M12x1.75	300

### 出力尺寸 Output

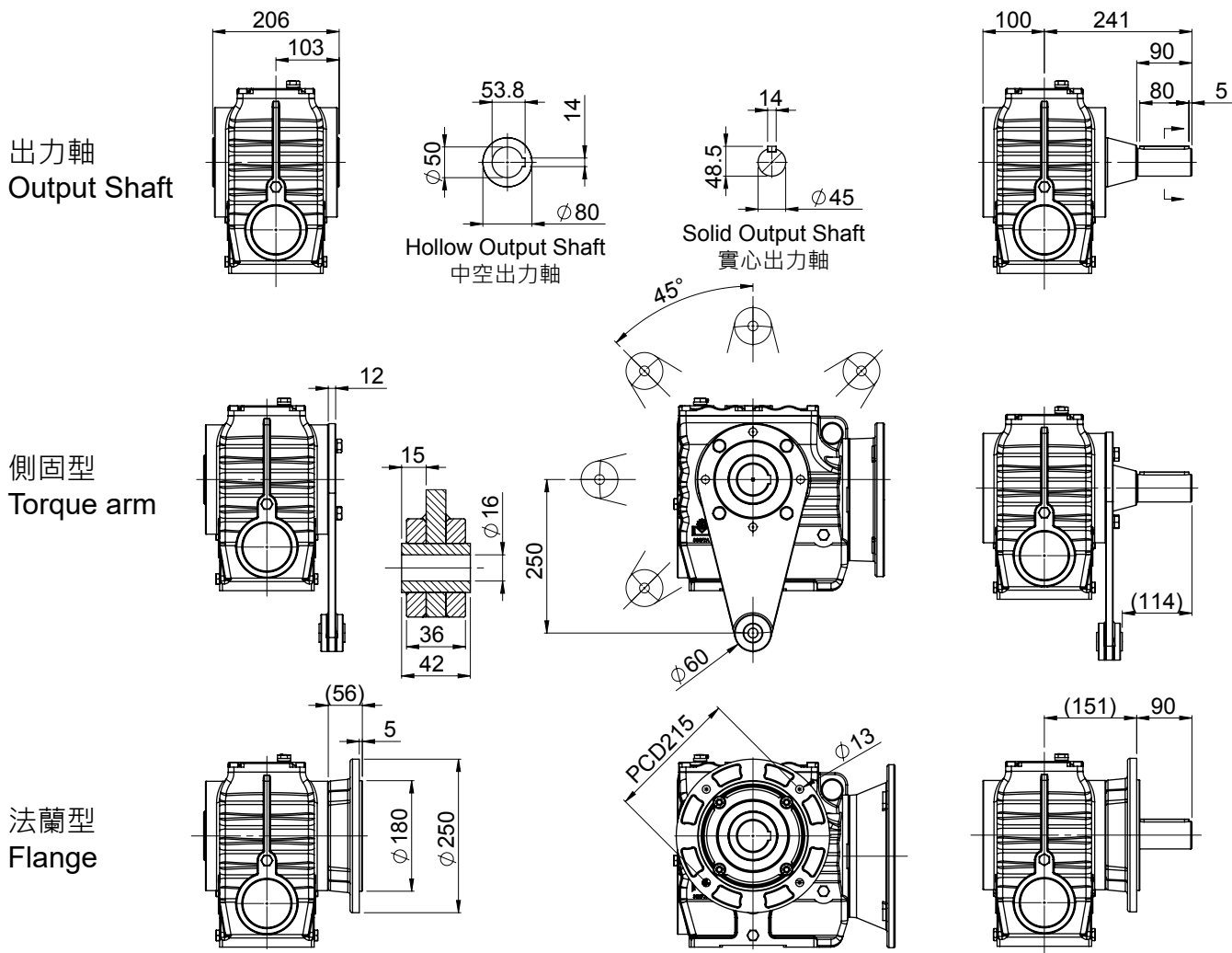

Power	1.5kW		2.2kW		3.7kW		5.5kW	
實際減速比 Actual Ratio	OT(Nm)	SF	OT(Nm)	SF	OT(Nm)	SF	OT(Nm)	SF
20	145	4.76	213	3.24	359	1.92	534	1.29
30	211	3.04	309	2.08	521	1.23	774	0.83
40	291	3.01	427	2.05	718	1.22	996	0.61
45	316	2.31	464	1.57	781	0.93	1161	0.62
60	422	1.91	619	1.3	1042	0.77	1350	0.51
80	543	1.42	797	0.97	1340	0.57		
90	552	1.42	810	0.97	1363	0.57		
100	548	1.14	804	0.78				
120	736	1.17	1080	0.8				
140 (141)	822	0.85	1206	0.58				
160	943	0.81	1383	0.55				
180	1002	0.64						
200	1097	0.69						
240	1336	0.51						

# GEAR-WORM REDUCER SERIES

## 齒蝸輪減速機系列

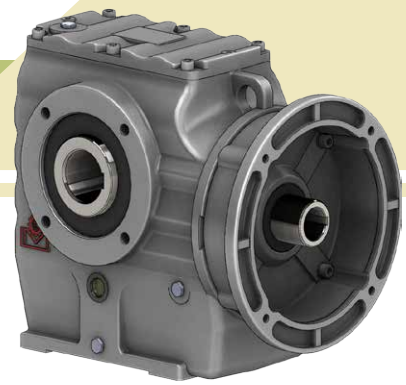

MODEL : AS087

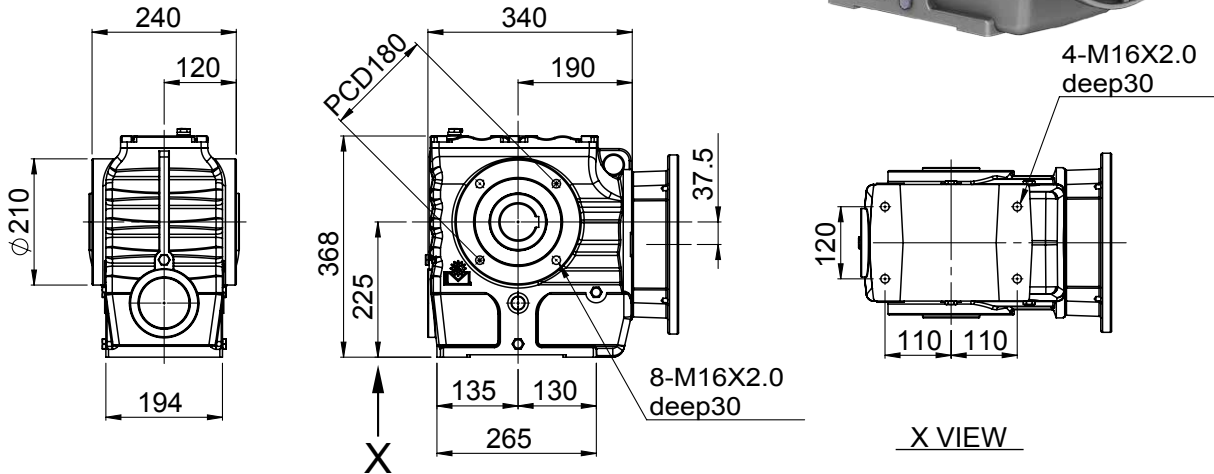

### 入力尺寸 Input

入力法蘭  
Input Flange

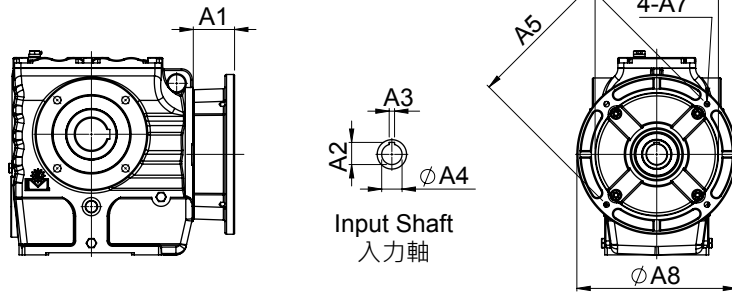

入力軸  
Input Shaft

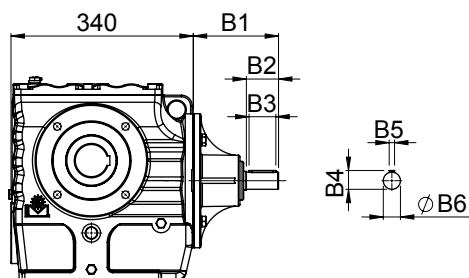

unit: mm

Power	A1	A2	A3	A4	A5	A6	A7	A8	B1	B2	B3	B4	B5	B6
2.2 kW 3.7 kW	57	31.3	8	28	215	180	M12x1.75	250	159	60	50	35	10	Ø32
5.5 kW 7.5 kW	77	41.3	10	38	265	230	M12x1.75	300	164	65	55	41	10	Ø38
11 kW	112	45.3	12	42	300	250	M16x2.0	350	164	65	55	41	10	Ø38

### 出力尺寸 Output

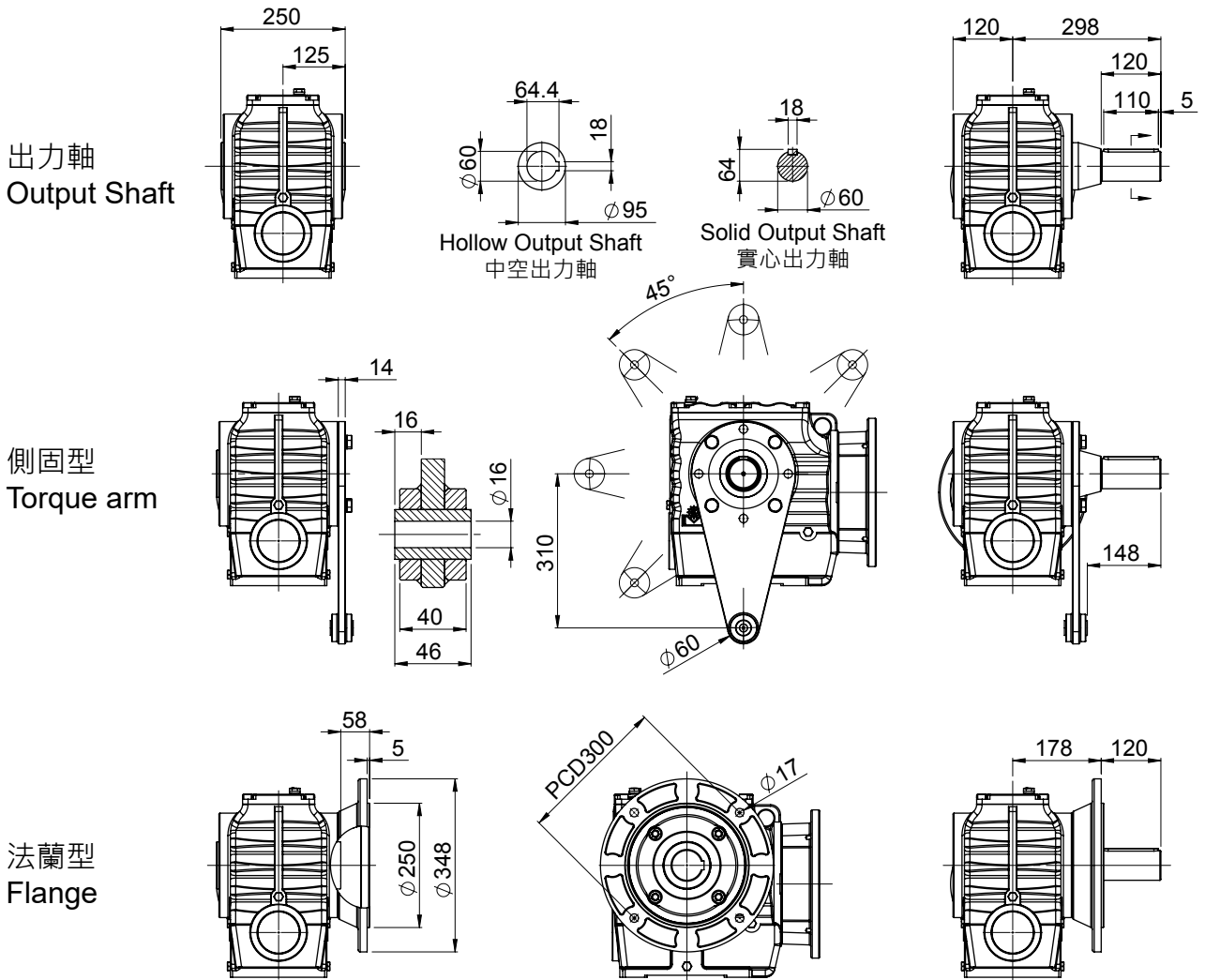

Power	2.2kW		3.7kW		5.5kW		7.5kW		11kW	
實際減速比 Actual Ratio	OT(Nm)	SF	OT(Nm)	SF	OT(Nm)	SF	OT(Nm)	SF	OT(Nm)	SF
20	208	5.34	351	3.17	522	2.13	712	1.56	1044	1.06
30	313	4.09	527	2.43	783	1.63	1068	1.2	1567	0.81
40	417	3.38	702	2	1044	1.35	1424	0.99	2089	0.67
45	480	2.73	808	1.62	1202	1.09	1639	0.79	2404	0.54
60	641	2.26	1078	1.34	1603	0.9	2186	0.66		
80	835	1.75	1405	1.04	2089	0.7	2849	0.51		
90	864	1.6	1454	0.95	2161	0.64				
100	840	1.21	1413	0.72	2101	0.48				
120	1152	1.32	1938	0.78	2881	0.52				
140 (141)	1260	0.91	2120	0.54						
160	1479	1.01	2488	0.6						
180	1534	0.74								
200	1681	0.74								
240	2046	0.6								



# GEAR-WORM REDUCER SERIES

## 齒蝸輪減速機系列

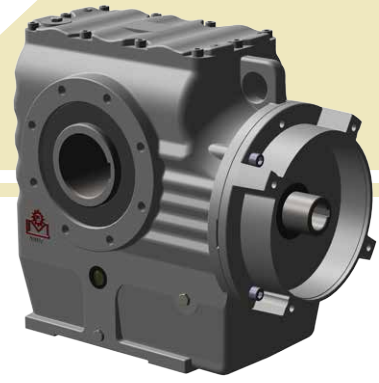

MODEL : AS097

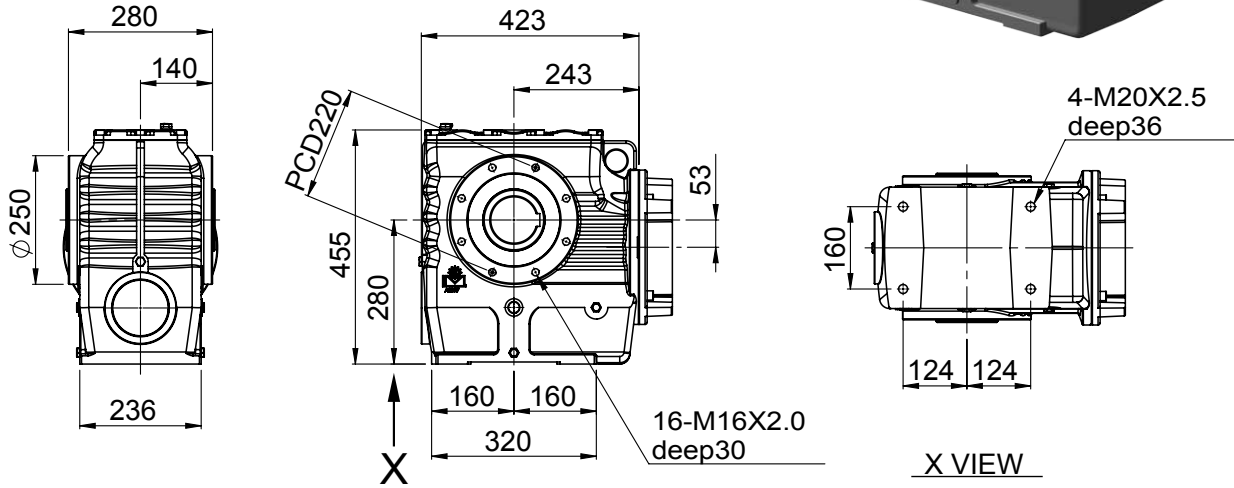

### 入力尺寸 Input

入力法蘭  
Input Flange

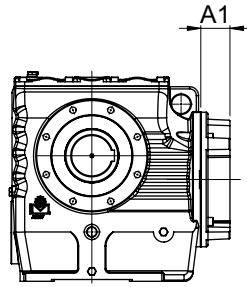

Input Shaft  
入力軸

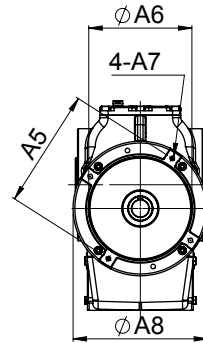

入力軸  
Input Shaft

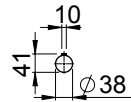
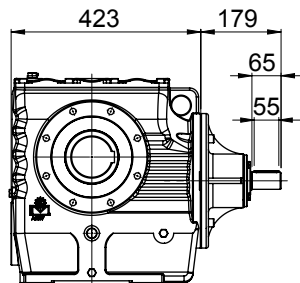

unit: mm

Power	A1	A2	A3	A4	A5	A6	A7	A8
5.5 kW 7.5 kW	65	41.3	10	38	265	230	M12x1.75	300
11 kW 15 kW	93	45.3	12	42	300	250	M16x2.0	350

## 出力尺寸 Output

出力軸  
Output Shaft

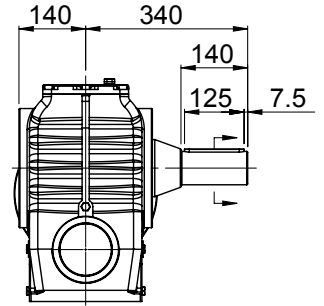
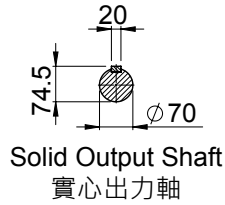
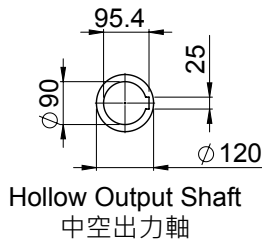
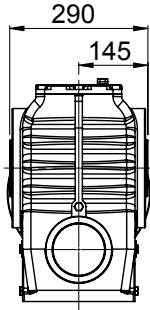

側固型  
Torque arm

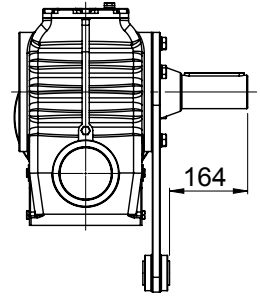
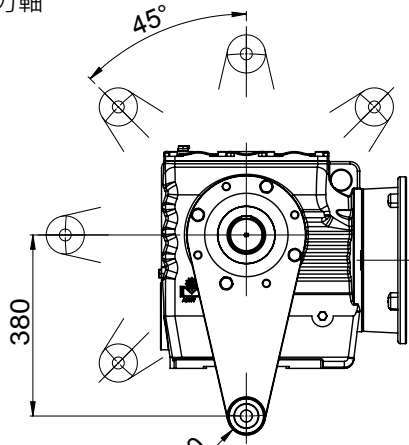
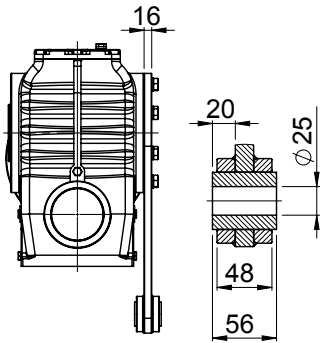

法蘭型  
Flange

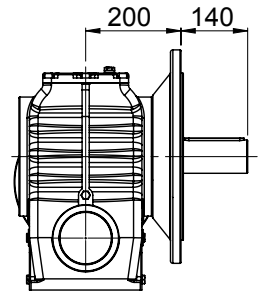
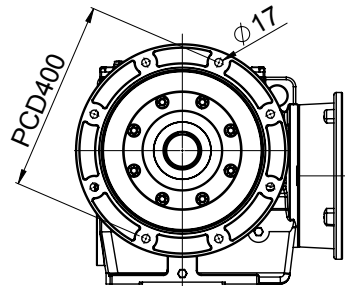
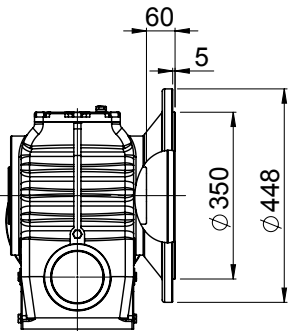

Power	5.5kW		7.5kW		11kW		15kW	
實際減速比 Actual Ratio	OT(Nm)	SF	OT(Nm)	SF	OT(Nm)	SF	OT(Nm)	SF
20	552	3.41	753	2.50	1105	1.71	1506	1.25
30	829	2.66	1130	1.95	1657	1.33	2260	0.97
40	1105	2.18	1506	1.60	2210	1.09	3013	0.80
45	1202	1.88	1640	1.38	2405	0.94	3279	0.69
60	1603	1.56	2186	1.14	3206	0.78	4372	0.57
80	2089	1.32	2849	0.96	4179	0.66		
90	2161	1.11	2947	0.82	4323	0.56		
100	2192	0.88	2988	0.64				
120	2882	0.91	3930	0.67				
150 (148)	3287	0.66	4483	0.48				
160	3699	0.76	5043	0.56				
200	4383	0.53						